



Niagara Frontier Transportation Authority
Serving the Niagara Region

ECLEG APR11 '11 AM 9:48

181 Ellicott Street
Buffalo, New York 14203
www.nfta.com

ED

Kimberley Minkel
Executive Director
716-855-7470
Fax: 716-855-6655
E-mail: kim_minkel@nfta.com

March 31, 2011

Barbara Miller-Williams, Chairperson
Erie County Legislature
92 Franklin Street, 4th Floor
Buffalo, NY 14202

Re: Niagara Frontier Transportation Authority

Dear Chairperson Miller-Williams:

Enclosed is a CD containing a PDF version of the *revised* five year capital plan for fiscal years ending March 31, 2012–2016 and the annual operating budget for fiscal year end 2012. On December 20, 2010, the NFTA Board passed the budget and pursuant to Public Authorities Law Section 2801 this was submitted prior to December 31, 2010. However, we have updated the budget assumptions noted below based on more current information and we presenting a revised balanced budget without a fare increase for FYE '12.

- Revenues are increasing \$1,533,388 primarily due to increased Metro passenger fares, BNIA and NFIA revenues, based on more recent trends.
- Operating assistance is increasing \$605,650 due to higher mortgage recording tax based on more recent trends.
- Expenses are increasing \$2,326,836 primarily the result of higher transit fuel expenses (\$3.10/gallon diesel fuel), increased Metro salaries reflecting restored service levels and higher NFIA salaries based on increased business activity, partially offset by lower health insurance costs, based on recent trends and includes LMHF-GHI consolidation savings.
- Capital will be reduced \$187,798 based on updated funding levels.

If you have any questions regarding the enclosed, please contact Deborah C. Leous, Chief Financial Officer, at (716) 855-7250.

Very truly yours,

Kimberley Minkel
Executive Director

KM/cf
Enclosure

8M-18

**MANAGEMENT'S CERTIFICATION OF THE BUDGET
AND FINANCIAL PLAN**

The management of the Niagara Frontier Transportation Authority is responsible for the preparation and presentation of the Authority's budget and financial plan in accordance with Section 203.9 of 2 NYCRR. Management is also responsible for and certifies to the reasonableness of the assumptions, methods of estimation and judgments inherent in the preparation of the budget, and that these regulations have been satisfied.

Niagara Frontier Transportation Authority



Kimberley Minkel
Executive Director

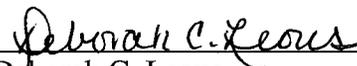

Deborah C. Leous
Chief Financial Officer

March 28, 2011

**NIAGARA FRONTIER
TRANSPORTATION AUTHORITY**

TO: NFTA Board of Commissioners
FROM: Kimberley A. Minkel
Executive Director 
SUBJECT: NFTA FY 2011-12
Operating and Capital Budget

Presented herein and in the accompanying documents is a balanced operating and capital budget for the NFTA's fiscal year ending March 31, 2012.

The Authority is projecting operating income for FYE 12 of \$16.8 million, offset by capital spending of \$4.0 million and non-operating expenditures totaling \$12.8 million. This budget is designed to protect the financial well being of the Authority without increasing transit fares to our customers.

BUDGET OVERVIEW

Operating Revenues

Consolidated FYE 12 revenues of \$98,607k are \$3,958k, or 4.2%, above FYE 11. This increase is attributable to higher Metro, BNIA, NFIA and Property Management revenues, partially offset by lower Transportation Centers' revenue.

NFTA operating revenues of \$65,821k are \$2,448k, or 3.9%, above FYE 11. NFTA revenues are generated from four business centers: Buffalo Niagara International Airport (BNIA), Niagara Falls International Airport (NFIA), Transportation Centers (MTC and NFITC) and Property Management. Revenue increases of \$1,696k, \$517k and \$296k at our BNIA, NFIA, and Property Management

operations, respectively, are partially offset by decreases of \$61k in our Transportation Centers.

Niagara Frontier Transit Metro, Inc. (Metro) operating revenues of \$32,786k are \$1,510k, or 4.8% above FYE 11. Metro operating revenues are generated from two sources, farebox and advertising on our buses, stations and bus shelters.

Operating Expenses

Consolidated FYE 12 operating expenses of \$175,841k are \$4,446k, or 2.6%, above FYE 11. A number of factors contribute to the increase:

- Metro salary increases of \$1,294k due to restoration of service levels and alleviation of capacity issues.
- Increase in NFTA/Metro workers' compensation costs of \$1,243k, or 20.2%, more in line with our FYE 11 forecast and reflective of recent trends.
- Increase in NFTA/Metro pension costs of \$982k, or 9.4%, factoring in NFTA early retirement incentive costs.
- Decrease in NFTA/Metro health insurance costs of \$243k, or 1.1%, as our favorable experience rating mitigates an anticipated 5.0% rate hike.
- Increase in Safety & Security of \$427k, or 3.9%, due to an increase in pension and workers' compensation costs, partially offset by a decrease in health insurance costs.
- Increase in Transit Fuel/Power expenses of \$2,312k, or 36.6%, due to higher diesel fuel costs. FYE 12 budget anticipates \$3.10/gal #2 ULSD diesel fuel, FYE 11 actual market prices have ranged from a low of \$2.00/gal on 7/05/10 to a high of \$3.30/gal on 2/28/11.
- Increase in NFTA/Metro utility costs of \$523k, or 8.4%, more in line with our FYE 11 forecast and includes a 3.0% commodity rate hike.
- Decrease in Personnel Service costs of \$1,241k attributable to early retirement/staffing adjustments.

- Increase in Costs Transferred to Capital Projects (net decrease in operating expenses) of \$573k, or 30.3%, attributable to a transit police reclassification of funds previously recognized as operating assistance.

Operating Assistance

Operating assistance provided by federal, state, and local governments for Metro operations of \$93,735k is \$1,490k or 1.6%, above FYE 11. Also included is \$325k for miscellaneous Federal grants for operations in our Executive branch (Transit Police department.)

Total Federal assistance of \$12,380k is \$715k below FYE 11 levels due to a reclassification of transit operating assistance reflective of our FYE 11 forecast.

We are assuming New York State Operating Assistance (STOA) will remain flat. Miscellaneous other grants total \$1,537k.

	<u>FYE 11</u> (000's)	<u>FYE 12</u> (000's)
STOA:		
• General Fund Section 18(b) (requires local match)	4,100	4,100
• Public Transportation Operation Assistance Funds	<u>37,907</u>	<u>37,907</u>
TOTAL	\$42,007	\$42,007
Additional State Operating Assistance:		
• Miscellaneous Other Grants	<u>\$1,537</u>	<u>\$1,537</u>
TOTAL STATE OPERATING ASSISTANCE	<u>\$43,544</u>	<u>\$43,544</u>

Local operating assistance is increasing 1.9% to \$38,136k. Reflective of more recent trends and more in line with our FYE 11 forecast, Erie County Sales Tax is increasing \$701k, or 4.1% and Mortgage Tax is decreasing \$13k, or 0.2%. Local 88c funds are increasing \$801k, or 9.8%.

	<u>FYE 11</u> (000's)	<u>FYE 12</u> (000's)
Local assistance includes:		
• Erie County Sales Tax	\$16,930	\$17,632
• Mortgage Recording Tax	7,246	7,233
• 88(c)	8,170	8,971
• Erie County match to 18(b)	3,657	3,657
• Niagara County match to 18(b)	443	443
• Peace Bridge	<u>200</u>	<u>200</u>
TOTAL	<u>\$37,398</u>	<u>\$38,136</u>

Non-operating Items

The FYE 12 budget includes \$12,421k in BNIA net debt service and operating reserves related to the Buffalo Niagara International Airport Improvement Program (AIP) project, debt service for construction of our new NFIA terminal, glycol collection operation and energy initiative program. Finally, Property Management debt service of \$266k and Noresco (energy initiative, non-BNIA) debt of \$374k were partially offset by interest income of \$262k.

Capital Expenditures

The NFTA commitment to protecting its existing assets and investing in the future of Western New York is evidenced in the proposed capital plan. The total amount for capital projects projected for FYE 12 is \$71.4 million, with the NFTA equity share at \$4.0 million.

NFTA BUSINESS CENTERS

The NFTA's business centers are organized into three strategic business units. The Surface Transportation Group includes Metro and the Transportation Centers. The Aviation Group includes the Buffalo Niagara International Airport and the Niagara Falls International Airport. The Property Group is responsible for the planning and management of the non-transportation property assets of the NFTA.

In addition to establishing program and service objectives, which define the level of planned achievements, activities and management direction, each business center has been charged with developing key performance indicators for FYE 12. These key performance indicators are included in the detailed business center section. Our goal is to tie future operating revenue projections, expenditure allocations, and capital needs to performance as represented by these indicators.

Surface Transportation Group

Metro

Niagara Frontier Transit Metro System, Inc. provides bus and rail transportation services within Erie and Niagara Counties. It is also responsible to implement the paratransit service mandated by the American with Disabilities Act, which began in FYE 94. Metro is the NFTA's largest business center and, due to the public service nature of its operations, it receives operating assistance from federal, state and local governments.

FYE 12 operating revenues of \$32,786k are \$1,510k, or 4.8%, above FYE 11. FYE 12 passenger fares are \$1,681k, or 5.5%, above budget, more in line with our FYE 11 forecast and includes funds for the Buffalo Niagara Medical Campus initiative.

FYE 12 fully allocated expenses of \$126,791k are \$4,334k, or 3.5%, above FYE 11. Personnel Services are \$1,941k, or 2.3%, above FYE 11 as an increase in salaries, workers' compensation and pension costs were partially offset by health insurance savings due to a favorable experience rating. Transit Fuel/Power is increasing \$2,312k, or 36.6%, as we anticipate our #2 ULSD diesel fuel to average \$3.10/gal for FYE 12. FYE 11 actual market prices have ranged from a low of \$2.00/gal on 7/05/2010 to a high of \$3.30/gal on 2/28/11.

Utilities are increasing \$238k, or 10.7%, more in line with our FYE 11 forecast and includes a 3.0% commodity rate hike. Safety & Security is increasing \$419k, or 9.1%, consistent with a more viable presence in our rail stations and factors in higher pension and workers' compensation costs, partially offset by lower health insurance costs. General Business/Other is \$227k, or 2.0%, below FYE 11 due to lower Metro management fees with our early retirement incentive program and lower travel and training costs.

FYE 12 capital: NFTA funded \$2,051k, grant funded \$30,745k, 88(c) funded \$1,615k. Major projects include LRV Mid-life Rebuild - \$9,000k, 24 Transit/Hybrid Buses - \$14,755k, 6 Diesel Buses - \$3,900k.

Transportation Centers

The Transportation Centers business center manages the Metropolitan Transportation Center bus terminal in Buffalo and the Niagara Falls International Transportation operation in Niagara Falls.

FYE 12 revenues of \$1,778k are \$61k, or 3.3%, below FYE 11, more in line with our FYE 11 forecast of lower office space rental fees.

FYE 12 fully allocated expenses of \$2,690k are \$57k, or 2.1%, below FYE 11. Personnel Services are \$72k, or 4.9%, below FYE 11 due to early retirement savings, lower consultant, overtime and health insurance costs, partially offset by an increase in contractual salaries, workers' compensation and pension costs. Utilities are increasing \$39k, or 8.3%, more in line with our FYE 11 forecast and anticipates a FYE 12 3.0% commodity rate hike. Safety & Security is \$50k, or 9.7%, below FYE 11 as a more viable presence in our rail stations and a higher allocation of police time spent at our Boat Harbor operation reduced the allocation to our Transportation Centers. General Business/Other is decreasing \$36k, or 3.8%, due to lower rent and postage costs. Inter Division Reimbursement is \$96k, or 7.5%, below FYE 11, more in line with our FYE 11 forecast and reflective of lower overall Transportation Center costs allocated to other areas of the organization.

FYE 12 capital: NFTA funded \$563k, grant funded \$356k, other funding \$1,494k. Major projects include the NFITC Capital Lease - \$417k.

Aviation Group

Buffalo Niagara International Airport

Buffalo Niagara International Airport is the primary commercial service airport for Erie and Niagara Counties. As such, it is a major element of the Niagara Frontier's transportation infrastructure as well as being an airline passenger's first impression of the local community. An airport improvement program has significantly upgraded the gateway image of the airport and provides the community with low cost quality air transportation.

FYE 12 operating revenues of \$58,494k are \$1,696k, or 3.0%, above FYE 11. Operating and financing costs are factored into compensatory airline billings through our Airport Fees & Services and Rental Income. Airport Fees and Services are \$907k, or 5.8%, above FYE 11 due to higher direct and indirect landing area expenses, decreases in interest income offsetting these higher expenses, higher operating expense reserves, and an increase in our general aviation revenue, more in line with our FYE 11 forecast. These increases were partially offset by a lower NFIA net deficit (BNIA signatory airlines reimburse the NFTA for 50% of NFIA's net deficit). Concessions/Commissions are \$535k, or 1.9%, above FYE 11 due to a 2% increase in enplanements and contractual increases with our auto rental tenants. Other Operating Revenues are increasing \$300k, or 10.8%, as higher direct airline billings for maintenance costs in the operation of our baggage handling system contributes to the increase.

FYE 12 fully allocated expenses of \$37,878k are \$262k, or 0.7%, above FYE 11. Personnel Services are \$176k, or 1.4%, above FYE 11 due to an increase in contractual salaries, health insurance, workers' compensation and pension costs, partially offset by early retirement savings. Maintenance & Repairs are increasing \$168k, or 2.0%, as higher runway and parking lot rehab costs and increasing terminal HVAC/elevator/escalator repair expenses contribute to the increase. Utilities are increasing \$248k, or 10.2%, more in line with our FYE 11 forecast as costs associated with our baggage handling system are well established. Safety & Security is decreasing \$213k, or 3.8%, more in line with our FYE 11 forecast. Inter Division Reimbursement is \$57k, or 3.1%, above FYE 11 due to increases in our Facilities Maintenance Department health insurance, workers' compensation and pension costs.

Non-operating items of \$13,841k are \$1,001k, or 6.7% below FYE 11 due chiefly to the anticipated receipt of \$1,000k in FAA entitlement funds offsetting our NFIA debt service costs.

FYE 12 capital: PFC funded \$3,231k, NFTA restricted/reserved \$1,753k, grant funded \$7,244k, other funding \$32k. Major projects include Noise Compatibility Study - \$5,912k, Parking Garage - Two Tier Road Rehab - \$1,306k, Automatic Bus Sort System - \$1,000k.

Niagara Falls International Airport

Niagara Falls International Airport is a joint use military/general aviation airport that currently provides general aviation and air cargo service. NFIA has been designated by the Federal Aviation Administration as a reliever airport to attract general aviation traffic from Buffalo Niagara International Airport. Construction of our new 69,430 square-foot, \$32.5 million terminal is revitalizing the airport providing an economic boost to the entire region and stimulating business activity.

FYE 12 revenues of \$1,147k are \$517k, or 82.1%, above FYE 11 are due to higher parking lot revenues with our anticipated increase in business activity.

FYE 12 fully allocated expenses of \$4,420k are \$657k, or 17.5% above FYE 11. Personnel Services are \$302k, or 26.4%, above FYE 11 due to increases in staffing, workers' compensation and pension costs, partially offset by lower health insurance costs. Maintenance & Repairs are increasing \$58k, or 6.9%, due to the allocation of a dedicated BNIA facilities maintenance department staff person. Utilities are \$15k, or 4.2%, below FYE 11, more in line with our FYE 11 forecast as usage numbers are now well established with our new terminal. Safety & Security is increasing \$226k, or 199.2%, based on a more visible police presence with our new terminal and expanded operation. General Business/Other is \$102k, or 21.0%, above FYE 11 due to higher parking lot expenses based on an anticipated increase in business activity.

FYE 12 non-operating net revenues of \$1,670k are \$17k, or 1.0%, above FYE 11 due to an increase in the annual contribution billable to the BNIA signatory airlines, representing 50% of the FYE 12 NFIA net deficit.

FYE 12 capital expenses: PFC funded \$371k, grant funded \$14,737k, other funding \$587k. Major projects include Safety Area R/W Improvement - \$14,126k, Mill and Overlay R/W - \$587k.

Property Group

Property Management

The Property Management business center is responsible for planning and management of the non-transportation property assets of the NFTA. Its mission is to maximize the financial return to the Authority on its non-public transportation assets while improving and preserving the physical integrity of those buildings and grounds

FYE 12 operating revenues of \$4,402k are \$296k, or 7.2%, above FYE 11 due to new tenants at our 485 Cayuga facilities and higher Boat Harbor fees, more in line with our FYE 11 forecast.

FYE 12 fully allocated expenses of \$3,748k are \$35k, or 0.9%, below FYE 11. Maintenance & Repairs are decreasing \$113k, or 20.7%, due to our Port Complex downsizing. Safety & Security is \$72k, or 903.0%, above FYE 11 as reallocation of police labor to our Boat Harbor operation contributes to the increase. General Business/Other is increasing \$36k, or 5.2%, due to an anticipated increase in fuel sales.

FYE 12 non-operating expenses of \$266k are \$34k, or 11.3%, below FYE 11 due to lower debt service costs.

FYE 12 capital: NFTA funded \$519k. Major projects include Launch Ramp Rehab - \$210k, 247 Cayuga Building Upgrade - \$83k.

SUPPORT SERVICES

The support service branches include Executive, General Counsel, Finance and Administration, Engineering, Human Resources and Public Affairs.

The support services are intended to assist the business centers in meeting their goals in such areas as revenue enhancement,

upgrading employee skills, and market research and planning. The expenses of these support services are charged to the business centers to the extent they are utilized. A full cost allocation plan has been implemented which distributes NFTA central administration expenses and capital costs to each business unit. Our long-range goal is to provide these support services more efficiently, thereby reducing costs to the business centers.

Each department of each support branch has also been charged with developing key performance indicators along with their level of program and service objectives for supporting the transportation business centers. As with the business centers, it is the intent to link operating budget needs to the level of support required.

Central Administration

FYE 12 NFTA expenses of \$8,683k are \$648k, or 6.9%, below FYE 11 due to early retirement savings, partially offset by higher health insurance, workers' compensation and pension costs.

FYE 12 capital: NFTA funded \$894k, grant funded \$4,618k, 88(c) funded \$137k. Major projects include Lawson software upgrade - \$100k, Windows Citrix implementation - \$50k, Metro Garage Perimeter Security - \$4,385k, Regional Surveillance Center - \$600k.

PERSONNEL ISSUES

Providing transportation services is notably labor-intensive and personnel costs account for approximately three quarters of all operating expenses. Managing costs, therefore, to a great extent means managing human resources.

Providing multi-modal transportation services to our two county service territory from nine locations requires a diverse group of employees. NFTA employees belong to thirteen collective bargaining units representing responsibilities from public safety to bus operators, from clerical to maintenance. Both pay rates and work rules are set by union agreement. Authority initiatives to stabilize employee expenses have been realized as a majority of labor contract agreements contain employee contributions for medical expenses.

General Assumptions

General assumptions in our personnel services for FYE 12 are the following:

- Union cost increases reflective of labor agreements.
- Costs neutral contracts proposed for those that will expire.
- 0% wage increases for non-represented employees.
- Metro fringe benefit rate at 70.4%, FYE 11 is 69.8%.
- NFTA fringe benefit rate at 49.0%, FYE 11 is 46.9%.

Benefit Costs

A major component of employee costs are the legally or contractually obligated benefits for employees.

- Decreases in our health insurance costs of \$243k, or 1.1%, as our favorable experience rating mitigates an anticipated 5.0% rate hike.
- NFTA's pension costs are increasing \$982k, or 9.4%.
- Safety and control of workers' compensation incidents are a high priority. A Health, Safety and Environmental

team along with a worker's compensation department have been created to help manage our workers' compensation cases. Workers' compensation costs are increasing \$1,243k, or 20.2%, based on recent trends.

- As a self-insured provider of disability benefits, we can limit financial exposure by increasing the general health of our employees. Our wellness program provides blood pressure screening, cholesterol testing, weight loss clinics and stop smoking programs.

Overtime

The FYE 12 overtime budget is anticipated at \$6,377k, an increase of \$730k, or 13.0% above FYE 11, more in line with our FYE 11 forecast and \$447k, or 6.6%, below our FYE 10 actuals..

CAPITAL BUDGET

The NFTA does not generate enough revenue to cover operating costs as well as a full capital program. Of our total FYE 12 capital budget of \$71,357k, 80% comes from federal or state funding agencies, such as Federal Transit Administration (FTA), Federal Aviation Administration (FAA), and the New York State Department of Transportation (NYSDOT), reflecting government's ongoing investment in transportation. Another 2%, earmarked for Metro rail operations, is funded through our 88(c) program, while 5% comes from Passenger Facility Charges (PFC) to help with capital needs at our Buffalo Niagara International and Niagara Falls International Airports.

**NIAGARA FRONTIER TRANSPORTATION AUTHORITY
FY 2010-11 OPERATING BUDGET AND CAPITAL PLAN
VS.
FY 2011-12 OPERATING BUDGET AND CAPITAL PLAN**

BUSINESS CENTER	FYE 11 BUDGET	FYE 12 BUDGET	VARIANCE	%
SURFACE TRANSPORTATION GROUP				
METRO CONSOLIDATED				
Operating Revenues & Asst	123,521,379	126,520,647	2,999,268	2.4%
Operating Expenses	<u>122,457,189</u>	<u>126,790,878</u>	<u>4,333,688</u>	<u>3.5%</u>
Net Income/(Loss)	1,064,190	-270,231	-1,334,420	-125.4%
Non-operating Items:				
Interest Income	27,000	12,000	-15,000	-55.6%
Debt Service - Noresco	-309,524	-309,524	0	0.0%
Intercompany Transfer	-779,838	-700,000	79,838	-10.2%
Direct Capital	592,665	2,050,903	1,458,238	246.0%
Indirect Capital	<u>266,494</u>	<u>382,228</u>	<u>115,734</u>	<u>43.4%</u>
Total Capital	<u>859,159</u>	<u>2,433,131</u>	<u>1,573,972</u>	<u>183.2%</u>
Net Surplus/(Deficit)	-857,331	-3,700,885	-2,843,554	331.7%
TRANSPORTATION CENTERS				
Operating Revenues & Asst	<u>1,839,000</u>	<u>1,777,618</u>	-61,382	-3.3%
Operating Expenses	<u>2,736,243</u>	<u>2,679,602</u>	<u>-56,640</u>	<u>-2.1%</u>
Net Income/(Loss)	-897,243	-901,984	-4,742	0.5%
Non-operating Items:				
Debt Service - Noresco	-63,944	-64,037	-93	0.1%
Intercompany Transfer	779,838	700,000	-79,838	-10.2%
Direct Capital	494,064	563,040	68,976	14.0%
Indirect Capital	27,547	39,510	<u>11,963</u>	<u>43.4%</u>
Total Capital	<u>521,611</u>	<u>602,550</u>	<u>80,939</u>	<u>15.5%</u>
Net Surplus/(Deficit)	-702,959	-868,571	-165,612	23.6%
TOTAL SURFACE TRANSPORTATION				
Operating Revenues & Asst	125,360,379	128,298,265	2,937,886	2.3%
Operating Expenses	<u>125,193,432</u>	<u>129,470,480</u>	<u>4,277,048</u>	<u>3.4%</u>
Net Income/(Loss)	166,947	-1,172,215	-1,339,162	-802.1%
Non-operating Items:				
Interest Income	27,000	12,000	-15,000	-55.6%
Debt Service - Noresco	-373,468	-373,561	-93	0.0%
Direct Capital	1,086,729	2,613,943	1,527,214	140.5%
Indirect Capital	294,041	421,738	<u>127,697</u>	<u>43.4%</u>
Total Capital	<u>1,380,770</u>	<u>3,035,681</u>	<u>1,654,911</u>	<u>119.9%</u>
Net Surplus/(Deficit)	-1,560,290	-4,569,456	-3,009,166	192.9%

NIAGARA FRONTIER TRANSPORTATION AUTHORITY
FY 2010-11 OPERATING BUDGET AND CAPITAL PLAN
VS.
FY 2011-12 OPERATING BUDGET AND CAPITAL PLAN

BUSINESS CENTER	FYE 11 BUDGET	FYE 12 BUDGET	VARIANCE	%
AIRPORT BUSINESS GROUP				
BNIA				
Operating Revenues & Asst	56,797,492	58,493,913	1,696,421	3.0%
Operating Expenses	37,616,297	37,878,091	261,794	0.7%
Net Income/(Loss)	19,181,195	20,615,822	1,434,627	7.5%
Non-operating Items:				
Bond Debt Service	-14,284,239	-14,152,999	131,240	-0.9%
Oper Expense Reserve & R&R Rsv	-213,227	-294,202	-80,975	38.0%
NFIA Contribution (Excluding Debt Service)	-1,653,313	-1,670,091	-16,778	1.0%
NFIA Contribution - Debt Service	-2,180,160	-2,092,371	87,789	-4.0%
ADF NFIA Debt Service Funding	1,000,000	1,000,000	0	0.0%
Debt Service - Glycol Collection	-305,020	-300,415	4,605	-1.5%
Debt Service - Noresco	-272,994	-273,133	-139	0.1%
Interest Income	375,000	250,000	-125,000	-33.3%
Entitlements	0	1,000,000	1,000,000	n/a
PFC	2,691,920	2,691,920	0	0.0%
Direct Capital	73,000	0	-73,000	-100.0%
Indirect Capital	206,009	295,476	89,466	43.4%
Total Capital	279,009	295,476	16,466	5.9%
Net Surplus/(Deficit)	4,060,153	6,479,056	2,418,903	59.6%
NFIA				
Operating Revenues & Asst	629,924	1,147,207	517,283	82.1%
Operating Expenses	3,762,700	4,419,971	657,271	17.5%
Net Income/(Loss)	-3,132,776	-3,272,764	-139,988	4.5%
Non-operating Items:				
Gain on Sale	0	0	0	n/a
Debt Service	-2,180,160	-2,092,371	87,789	-4.0%
BNIA Contr (Excluding Debt Svc)	1,653,313	1,670,091	16,778	1.0%
BNIA Contribution - Debt Svc	2,180,160	2,092,371	-87,789	-4.0%
Direct Capital	228,695	0	-228,695	-100.0%
Indirect Capital	47,004	67,417	20,413	43.4%
Total Capital	275,699	67,417	-208,282	-75.5%
Net Surplus/(Deficit)	-1,755,162	-1,670,091	85,071	-4.8%
TOTAL AIRPORT BUSINESS GROUP				
Operating Revenues & Asst	57,427,416	59,641,120	2,213,704	3.9%
Operating Expenses	41,378,997	42,298,062	919,065	2.2%
Net Income/(Loss)	16,048,419	17,343,058	1,294,639	8.1%
Non-operating Items:				
Bond Debt Service	-14,284,239	-14,152,999	131,240	-0.9%
Oper Exp Reserve & R&R Rsv	-213,227	-294,202	-80,975	38.0%
Debt Service - Glycol Collection	-305,020	-300,415	4,605	-1.5%
Debt Service - Noresco	-272,994	-273,133	-139	0.1%
Debt Service - NFIA	0	0	0	n/a
NFIA Contribution	-1,653,313	-1,670,091	-16,778	1.0%
NFIA Contribution - Debt Service	-2,180,160	-2,092,371	87,789	0
ADF NFIA Debt Service Funding	1,000,000	1,000,000	0	0
Gain on Sale	0	0	0	n/a
Debt Service	-2,180,160	-2,092,371	87,789	0
BNIA Contr (Excluding Debt Svc)	1,653,313	1,670,091	16,778	0
BNIA Contribution - Debt Svc	2,180,160	2,092,371	-87,789	-4.0%
Interest Income	375,000	250,000	-125,000	-33.3%
Entitlements	0	1,000,000	1,000,000	n/a
PFC	2,691,920	2,691,920	0	0.0%
Direct Capital	301,695	0	-301,695	-100.0%
Indirect Capital	253,013	362,893	109,879	43.4%
Total Capital	554,708	362,893	-191,816	-34.6%
Net Surplus/(Deficit)	2,304,991	4,808,965	2,503,974	108.6%

**NIAGARA FRONTIER TRANSPORTATION AUTHORITY
FY 2010-11 OPERATING BUDGET AND CAPITAL PLAN
VS.
FY 2011-12 OPERATING BUDGET AND CAPITAL PLAN**

BUSINESS CENTER	FYE 11 BUDGET	FYE 12 BUDGET	VARIANCE	%
PROPERTY MANAGEMENT				
Operating Revenues & Asst	4,106,744	4,402,378	295,634	7.2%
Operating Expenses	<u>3,782,397</u>	<u>3,747,805</u>	<u>-34,591</u>	<u>-0.9%</u>
Net Income/(Loss)	324,347	654,573	330,225	101.8%
Non-operating Items:				
Property Mgmt Debt Service	-300,000	-266,000	34,000	-11.3%
Property Acquisition	0	0	0	n/a
Direct Capital	692,866	518,821	-174,045	-25.1%
Indirect Capital	76,178	109,260	33,083	43.4%
Total Capital	<u>769,044</u>	<u>628,081</u>	<u>-140,962</u>	<u>-18.3%</u>
Net Surplus/(Deficit)	-744,696	-239,509	505,187	-67.8%
CENTRAL ADMINISTRATION				
Operating Revenues & Asst	1,040,102	325,034	-715,068	-68.7%
Operating Expenses	<u>1,040,102</u>	<u>325,034</u>	<u>-715,068</u>	<u>-68.7%</u>
Net Income/(Loss)	0	0	0	n/a
Direct Capital	623,232	893,891	270,659	43.4%
Indirect Capital	-623,232	-893,891	-270,659	43.4%
Total Capital	<u>0</u>	<u>0</u>	<u>0</u>	<u>n/a</u>
Net Surplus/(Deficit)	0	0	0	n/a
CONSOLIDATED				
Operating Revenues & Asst	187,934,641	192,666,797	4,732,156	2.5%
Operating Expenses	<u>171,394,927</u>	<u>175,841,381</u>	<u>4,446,454</u>	<u>2.6%</u>
Net Income/(Loss)	16,539,714	16,825,416	285,702	1.7%
Non-operating Items:				
Bond Debt Service	-14,284,239	-14,152,999	131,240	-0.9%
Oper Exp Reserve & R&R Rsv	-213,227	-294,202	-80,975	38.0%
Debt Service - Glycol Collection	-305,020	-300,415	4,605	-1.5%
Debt Service - Noresco	-646,462	-646,694	-232	0.0%
NFIA Contribution (Excluding Debt Service)	-1,653,313	-1,670,091	-16,778	1.0%
NFIA Contribution - Debt Service	-2,180,160	-2,092,371	87,789	-4.0%
ADF NFIA Debt Service Funding	1,000,000	1,000,000	0	0.0%
Gain on Sale	0	0	0	n/a
Debt Service	-2,180,160	-2,092,371	87,789	-4.0%
BNIA Contr (Excluding Debt Svc)	1,653,313	1,670,091	16,778	1.0%
BNIA Contribution - Debt Svc	2,180,160	2,092,371	-87,789	-4.0%
Interest Income	402,000	262,000	-140,000	-34.8%
Intercompany Transfer - Metro	-779,838	-700,000	79,838	-10.2%
Intercompany Transfer - Transpo Ctrs	779,838	700,000	-79,838	-10.2%
Entitlements	0	1,000,000	1,000,000	n/a
PFC	2,691,920	2,691,920	0	0.0%
Property Mgmt Debt Service	-300,000	-266,000	34,000	-11.3%
Property Acquisition	0	0	0	n/a
Direct Capital	2,704,526	4,026,655	1,322,129	48.9%
Indirect Capital	0	0	0	n/a
Total Capital	<u>2,704,526</u>	<u>4,026,655</u>	<u>1,322,129</u>	<u>48.9%</u>
Net Surplus/(Deficit)	0	0	0	n/a

NIAGARA FRONTIER TRANSPORTATION AUTHORITY
FIVE YEAR CAPITAL PLAN
FY 2011/12 - 2015/16

03/16/11

COST CENTER	FUNDING	2011/12	2012/13	2013/14	2014/15	2015/16	OUT YEARS	TOTAL
SURFACE TRANSP. GROUP								
METRO BUS	FTA	\$16,035,496	\$41,746,232	\$18,808,133	\$29,739,010	\$802,419	\$2,052,878	\$109,184,168
	NYS DOT	\$2,004,436	\$5,186,652	\$2,351,017	\$3,717,376	\$100,302	\$256,610	\$13,616,393
	NFTA	\$2,004,436	\$4,933,640	\$2,351,017	\$3,717,376	\$100,302	\$256,610	\$13,363,381
	SUBTOTAL	\$20,044,368	\$51,866,524	\$23,510,167	\$37,173,762	\$1,003,023	\$2,566,098	\$136,163,942
METRO EXECUTIVE/METRO LINK	FTA	\$371,818	\$68,000	\$60,000	\$60,000	\$60,000	\$60,000	\$679,818
	NYS DOT	\$46,477	\$8,500	\$7,500	\$7,500	\$7,500	\$7,500	\$84,977
	NFTA	\$46,477	\$8,500	\$7,500	\$7,500	\$7,500	\$7,500	\$84,977
	SUBTOTAL	\$464,772	\$85,000	\$75,000	\$75,000	\$75,000	\$75,000	\$849,772
METRO RAIL								
RAIL MAINTENANCE	88-C	\$260,000	\$4,318,000	\$3,674,000	\$3,845,000	\$3,533,000	\$35,319,000	\$50,949,000
	FTA	\$0	\$0	\$0	\$0	\$0	\$0	\$0
	NYS DOT	\$0	\$0	\$0	\$0	\$0	\$0	\$0
	SUBTOTAL	\$260,000	\$4,318,000	\$3,674,000	\$3,845,000	\$3,533,000	\$35,319,000	\$50,949,000
RAIL CAR	88-C	\$418,000	\$1,274,000	\$463,000	\$249,000	\$269,000	\$0	\$2,673,000
	SUBTOTAL	\$418,000	\$1,274,000	\$463,000	\$249,000	\$269,000	\$0	\$2,673,000
RAIL - ENGINEERING	88-C	\$937,394	\$1,616,504	\$4,194,451	\$9,496,765	\$7,466,937	\$13,583,231	\$37,295,282
	FTA	\$7,641,825	\$8,248,878	\$3,280,067	\$4,585,309	\$3,781,251	\$80,406	\$27,617,736
	NYS DOT	\$931,579	\$3,800,278	\$7,885,319	\$1,684,484	\$472,656	\$10,051	\$14,784,367
	NYS DTF	\$3,713,400	\$3,713,400	\$438,181	\$0	\$0	\$0	\$7,864,981
	CITY OF BUFFALO	\$0	\$627,780	\$1,694,416	\$229,673	\$0	\$0	\$2,551,869
	ESCO	\$0	\$0	\$0	\$0	\$0	\$486,202	\$486,202
	FHWA	\$0	\$14,771,295	\$39,868,605	\$5,927,040	\$0	\$0	\$60,566,940
	INSURANCE	\$0	\$0	\$0	\$0	\$0	\$0	\$0
	PRIVATE	\$0	\$0	\$0	\$0	\$0	\$0	\$0
	SUBTOTAL	\$13,224,198	\$32,778,135	\$57,361,039	\$21,923,271	\$11,720,844	\$14,159,890	\$151,167,377
	TOTAL METRO RAIL							
FTA		\$7,641,825	\$8,248,878	\$3,280,067	\$4,585,309	\$3,781,251	\$80,406	\$27,617,736
NYS DOT		\$931,579	\$3,800,278	\$7,885,319	\$1,684,484	\$472,656	\$10,051	\$14,784,367
88-C		\$1,615,394	\$7,208,504	\$8,331,451	\$13,590,765	\$11,268,937	\$48,902,231	\$90,917,282
NYS DTF		\$3,713,400	\$3,713,400	\$438,181	\$0	\$0	\$0	\$7,864,981
CITY OF BUFFALO		\$0	\$627,780	\$1,694,416	\$229,673	\$0	\$0	\$2,551,869
ESCO		\$0	\$0	\$0	\$0	\$0	\$486,202	\$486,202
FHWA		\$0	\$14,771,295	\$39,868,605	\$5,927,040	\$0	\$0	\$60,566,940
INSURANCE		\$0	\$0	\$0	\$0	\$0	\$0	\$0
PRIVATE		\$0	\$0	\$0	\$0	\$0	\$0	\$0
SUBTOTAL		\$13,902,198	\$38,370,135	\$61,498,039	\$26,017,271	\$15,522,844	\$49,478,890	\$204,789,377
TOTAL METRO								
FTA		\$24,049,139	\$50,063,110	\$22,148,200	\$34,384,319	\$4,643,670	\$2,193,284	\$137,481,722
NYS DOT		\$2,982,492	\$8,995,430	\$10,243,836	\$5,409,360	\$580,458	\$274,161	\$28,485,737
NFTA		\$2,050,913	\$4,942,140	\$2,358,517	\$3,724,876	\$107,802	\$264,110	\$13,448,358
88-C		\$1,615,394	\$7,208,504	\$8,331,451	\$13,590,765	\$11,268,937	\$48,902,231	\$90,917,282
NYS DTF		\$3,713,400	\$3,713,400	\$438,181	\$0	\$0	\$0	\$7,864,981
CITY OF BUFFALO		\$0	\$627,780	\$1,694,416	\$229,673	\$0	\$0	\$2,551,869
ESCO		\$0	\$0	\$0	\$0	\$0	\$486,202	\$486,202
FHWA		\$0	\$14,771,295	\$39,868,605	\$5,927,040	\$0	\$0	\$60,566,940
INSURANCE		\$0	\$0	\$0	\$0	\$0	\$0	\$0
PRIVATE		\$0	\$0	\$0	\$0	\$0	\$0	\$0
TOTAL		\$34,411,338	\$90,321,659	\$85,083,206	\$63,266,033	\$16,600,867	\$52,119,988	\$341,803,091

NIAGARA FRONTIER TRANSPORTATION AUTHORITY
 FIVE YEAR CAPITAL PLAN
 FY 2011/12 - 2015/16

COST CENTER	FUNDING	2011/12	2012/13	2013/14	2014/15	2015/16	OUT YEARS	TOTAL
TRANSP. CENTERS								
	NFTA	\$563,040	\$2,010,355	\$1,448,583	\$478,680	\$416,942	\$416,942	\$5,334,542
	FTA	\$160,000	\$0	\$0	\$0	\$0	\$0	\$160,000
	NYSDOT	\$20,000	\$0	\$0	\$0	\$0	\$0	\$20,000
	NYTEC	\$176,196	\$12,754	\$64,551	\$0	\$0	\$0	\$253,501
	88C	\$0	\$21,979	\$23,238	\$0	\$0	\$0	\$45,217
	FUTURE FUNDING	\$1,494,444	\$20,141,242	\$0	\$0	\$0	\$0	\$21,635,686
	SUBTOTAL	\$2,413,680	\$22,186,330	\$1,536,372	\$478,680	\$416,942	\$416,942	\$27,448,946
TOTAL SURFACE TRANSP. GROUP								
	FTA	\$24,209,139	\$50,063,110	\$22,148,200	\$34,384,319	\$4,643,670	\$2,193,284	\$137,641,722
	NYSDOT	\$3,002,492	\$8,995,430	\$10,243,836	\$5,409,360	\$580,458	\$274,161	\$28,505,737
	NFTA	\$2,613,953	\$6,952,495	\$3,807,100	\$4,203,556	\$524,744	\$681,052	\$18,782,900
	88-C	\$1,615,394	\$7,230,483	\$8,354,689	\$13,590,765	\$11,268,937	\$48,902,231	\$90,962,499
	NYSDTF	\$3,713,400	\$3,713,400	\$438,181	\$0	\$0	\$0	\$7,864,981
	ESCO	\$0	\$0	\$0	\$0	\$0	\$486,202	\$486,202
	CITY OF BUFFALO	\$0	\$627,780	\$1,694,416	\$229,673	\$0	\$0	\$2,551,869
	NYTEC	\$176,196	\$12,754	\$64,551	\$0	\$0	\$0	\$253,501
	FHWA	\$0	\$14,771,295	\$39,868,605	\$5,927,040	\$0	\$0	\$60,566,940
	INSURANCE	\$0	\$0	\$0	\$0	\$0	\$0	\$0
	PRIVATE	\$0	\$0	\$0	\$0	\$0	\$0	\$0
	FUTURE FUNDING	\$1,494,444	\$20,141,242	\$0	\$0	\$0	\$0	\$21,635,686
	TOTAL	\$36,825,018	\$112,507,989	\$86,619,578	\$63,744,713	\$17,017,809	\$52,536,930	\$369,252,037

NIAGARA FRONTIER TRANSPORTATION AUTHORITY
FIVE YEAR CAPITAL PLAN
FY 2011/12 - 2015/16

03/16/11

COST CENTER	FUNDING	2011/12	2012/13	2013/14	2014/15	2015/16	OUT YEARS	TOTAL
AIRPORT DEVELOPMENT GROUP								
BNIA								
FAA		\$6,227,547	\$5,093,093	\$8,147,746	\$7,802,371	\$21,280,237	\$21,987,300	\$70,538,294
NFTA		\$0	\$194,700	\$1,167,350	\$1,037,000	\$738,000	\$2,700,000	\$5,837,050
ADF		\$120,331	\$0	\$0	\$0	\$0	\$0	\$120,331
BNIA CAP. RES.		\$1,632,604	\$1,799,278	\$182,500	\$175,000	\$158,982	\$93,000	\$4,041,364
NYS DOT		\$845,424	\$651,853	\$1,122,212	\$1,051,371	\$3,285,048	\$3,265,365	\$10,221,273
SPECIAL COND. 7		\$0	\$0	\$0	\$0	\$0	\$0	\$0
PFC		\$2,371,278	\$2,075,700	\$32,489,880	\$854,783	\$2,280,812	\$5,765,365	\$45,837,818
FUTURE PFC		\$855,388	\$5,746,164	\$736,574	\$1,003,397	\$1,357,886	\$0	\$9,699,409
AIP		\$27,413	\$0	\$0	\$0	\$0	\$0	\$27,413
PFC (MATCH)		\$4,571	\$0	\$0	\$0	\$0	\$0	\$4,571
BOND		\$0	\$561,367	\$7,910,504	\$1,995,000	\$13,472,812	\$13,472,812	\$37,412,495
TSA		\$0	\$0	\$0	\$0	\$0	\$1,500,000	\$1,500,000
NYS DEC		\$4,646	\$0	\$0	\$0	\$0	\$0	\$4,646
TAP RESTRICTED		\$0	\$0	\$0	\$0	\$0	\$0	\$0
PENDING GRANT		\$170,606	\$175,000	\$0	\$0	\$0	\$0	\$345,606
DHS		\$0	\$0	\$0	\$0	\$0	\$0	\$0
SUBTOTAL		\$12,259,808	\$16,297,155	\$51,756,766	\$13,918,922	\$42,573,777	\$48,783,842	\$185,590,270
NFIA								
FAA		\$14,359,115	\$11,571,151	\$10,953,343	\$11,593,753	\$5,780,532	\$73,364,920	\$127,622,814
NFTA		\$0	\$593,414	\$1,061,405	\$1,072,053	\$4,711,630	\$21,137,879	\$28,576,381
ADF		\$223,792	\$0	\$0	\$0	\$0	\$0	\$223,792
NYS DOT		\$377,871	\$304,504	\$288,246	\$305,099	\$152,119	\$1,930,656	\$3,358,495
FTA		\$0	\$0	\$0	\$0	\$0	\$0	\$0
NATIONAL FUEL		\$0	\$0	\$0	\$0	\$0	\$0	\$0
NYS AIR 99		\$0	\$0	\$0	\$0	\$0	\$0	\$0
PFC		\$18,138	\$400,000	\$0	\$0	\$0	\$0	\$418,138
CITY OF NF		\$0	\$0	\$0	\$0	\$0	\$0	\$0
NFIA CAP RES		\$0	\$0	\$0	\$0	\$0	\$0	\$0
SEN BACKED LOAN		\$0	\$0	\$0	\$0	\$0	\$0	\$0
NYS MOU		\$0	\$0	\$0	\$0	\$0	\$0	\$0
NYS		\$0	\$0	\$0	\$0	\$0	\$0	\$0
AIRFORCE		\$362,767	\$4,779,911	\$0	\$0	\$0	\$0	\$5,142,678
FUTURE FUNDING		\$0	\$0	\$0	\$0	\$0	\$0	\$0
FUTURE PFC		\$353,145	\$505,000	\$0	\$0	\$0	\$0	\$858,145
PENDING PFC		\$0	\$0	\$0	\$0	\$0	\$250,000	\$250,000
BNIA CAP. RES.		\$0	\$27,387	\$125,165	\$0	\$0	\$0	\$152,552
ECONOMIC DEV		\$0	\$0	\$0	\$0	\$0	\$0	\$0
SUBTOTAL		\$15,694,828	\$18,181,367	\$12,428,159	\$12,970,905	\$10,644,281	\$96,683,455	\$166,602,995

NIAGARA FRONTIER TRANSPORTATION AUTHORITY
 FIVE YEAR CAPITAL PLAN
 FY 2011/12 - 2015/16

03/16/11

COST CENTER	FUNDING	2011/12	2012/13	2013/14	2014/15	2015/16	OUT YEARS	TOTAL
TOTAL AIRPORT DEVEL GROUP								
FAA		\$20,586,662	\$16,664,244	\$19,101,089	\$19,396,124	\$27,060,769	\$95,352,220	\$198,161,108
BNIA CAP. RES.		\$1,632,604	\$1,826,665	\$307,665	\$175,000	\$158,982	\$93,000	\$4,193,916
NYS DOT		\$1,223,295	\$956,357	\$1,410,458	\$1,356,470	\$3,437,167	\$5,196,021	\$13,579,768
PFC		\$2,389,416	\$2,475,700	\$32,489,880	\$854,783	\$2,280,812	\$5,765,365	\$46,255,956
FUTURE PFC		\$1,208,533	\$6,251,164	\$736,574	\$1,003,397	\$1,357,886	\$0	\$10,557,554
AIP		\$27,413	\$0	\$0	\$0	\$0	\$0	\$27,413
PFC (MATCH)		\$4,571	\$0	\$0	\$0	\$0	\$0	\$4,571
NYS DEC		\$4,646	\$0	\$0	\$0	\$0	\$0	\$4,646
NYS AIR 99		\$0	\$0	\$0	\$0	\$0	\$0	\$0
FTA		\$0	\$0	\$0	\$0	\$0	\$0	\$0
BOND		\$0	\$561,367	\$7,910,504	\$1,995,000	\$13,472,812	\$13,472,812	\$37,412,495
TSA		\$0	\$0	\$0	\$0	\$0	\$1,500,000	\$1,500,000
NFTA		\$0	\$788,114	\$2,228,755	\$2,109,053	\$5,449,630	\$23,837,879	\$34,413,431
ADF		\$344,123	\$0	\$0	\$0	\$0	\$0	\$344,123
CITY OF NF		\$0	\$0	\$0	\$0	\$0	\$0	\$0
NFIA CAP RES		\$0	\$0	\$0	\$0	\$0	\$0	\$0
SEN BACKED LOAN		\$0	\$0	\$0	\$0	\$0	\$0	\$0
NYS MOU		\$0	\$0	\$0	\$0	\$0	\$0	\$0
NYS		\$0	\$0	\$0	\$0	\$0	\$0	\$0
AIRFORCE		\$362,767	\$4,779,911	\$0	\$0	\$0	\$0	\$5,142,678
FUTURE FUNDING		\$0	\$0	\$0	\$0	\$0	\$0	\$0
PENDING PFC		\$0	\$0	\$0	\$0	\$0	\$250,000	\$250,000
SPECIAL COND. 7		\$0	\$0	\$0	\$0	\$0	\$0	\$0
ECONOMIC DEV		\$0	\$0	\$0	\$0	\$0	\$0	\$0
TAP RESTRICTED		\$0	\$0	\$0	\$0	\$0	\$0	\$0
PENDING GRANT		\$170,606	\$175,000	\$0	\$0	\$0	\$0	\$345,606
NATIONAL FUEL		\$0	\$0	\$0	\$0	\$0	\$0	\$0
DHS		\$0	\$0	\$0	\$0	\$0	\$0	\$0
TOTAL		\$27,954,636	\$34,478,522	\$64,184,925	\$26,889,827	\$53,218,058	\$145,467,297	\$352,193,265

NIAGARA FRONTIER TRANSPORTATION AUTHORITY
FIVE YEAR CAPITAL PLAN
FY 2011/12 - 2015/16

03/16/11

COST CENTER	FUNDING	2011/12	2012/13	2013/14	2014/15	2015/16	OUT YEARS	TOTAL
PROPERTY DEVELOPMENT GROUP								
	NFTA	\$188,636	\$733,145	\$1,785,463	\$155,000	\$8,950,000	\$0	\$11,812,244
	NYSDEC	\$0	\$0	\$0	\$0	\$0	\$0	\$0
	FHWA	\$0	\$0	\$0	\$0	\$0	\$0	\$0
	FTA	\$0	\$0	\$0	\$0	\$0	\$0	\$0
	PROP CAP. RES.	\$0	\$0	\$0	\$0	\$0	\$0	\$0
	ECC	\$0	\$0	\$0	\$0	\$0	\$0	\$0
	TOTAL	\$188,636	\$733,145	\$1,785,463	\$155,000	\$8,950,000	\$0	\$11,812,244
BOAT HARBOR								
	NFTA	\$330,185	\$421,005	\$4,169,896	\$10,000	\$10,000	\$0	\$4,941,086
	BH CAP. RES.	\$0	\$0	\$0	\$0	\$0	\$0	\$0
	FUTURE FUNDING	\$0	\$353,545	\$3,781,140	\$95,000	\$0	\$0	\$4,229,685
	TOTAL	\$330,185	\$774,550	\$7,951,036	\$105,000	\$10,000	\$0	\$9,170,771
CENTRAL ADMINISTRATION								
EXECUTIVE								
	NFTA	\$633,991	\$416,500	\$2,160,000	\$30,000	\$30,000	\$0	\$3,270,491
	TSGP 07	\$0	\$0	\$0	\$0	\$0	\$0	\$0
	TSGP 08	\$777,227	\$0	\$0	\$0	\$0	\$0	\$777,227
	TSGP 09	\$3,411,685	\$0	\$0	\$0	\$0	\$0	\$3,411,685
	UASI	\$0	\$0	\$0	\$0	\$0	\$0	\$0
	TSGP SUP 08	\$0	\$0	\$0	\$0	\$0	\$0	\$0
	DHS 09	\$0	\$0	\$0	\$0	\$0	\$0	\$0
	DHS 10	\$300,000	\$0	\$0	\$0	\$0	\$0	\$300,000
	88C	\$136,754	\$93,000	\$93,000	\$93,000	\$93,000	\$0	\$508,754
	COUNTER TERR. GRANT	\$0	\$0	\$0	\$0	\$0	\$0	\$0
	PFC	\$110,000	\$110,000	\$110,000	\$110,000	\$110,000	\$0	\$550,000
	TSGP ARRA	\$250,000	\$0	\$0	\$0	\$0	\$0	\$250,000
	SUBTOTAL	\$5,619,657	\$619,500	\$2,363,000	\$233,000	\$233,000	\$0	\$9,068,157
ENGINEERING								
	NFTA	\$0	\$10,500	\$11,000	\$31,500	\$43,900	\$12,500	\$109,400
	SUBTOTAL	\$0	\$10,500	\$11,000	\$31,500	\$43,900	\$12,500	\$109,400
CASH MANAGEMENT								
	NFTA	\$50,000	\$0	\$0	\$0	\$0	\$0	\$50,000
GRANTS								
	FTA	\$159,198	\$0	\$0	\$0	\$0	\$0	\$159,198
	NYS DOT	\$19,900	\$0	\$0	\$0	\$0	\$0	\$19,900
	NFTA	\$19,900	\$0	\$0	\$0	\$0	\$0	\$19,900
	SUBTOTAL	\$198,998	\$0	\$0	\$0	\$0	\$0	\$198,998
MIS								
	NFTA	\$190,000	\$79,000	\$44,000	\$54,000	\$54,000	\$0	\$421,000
	88C	\$0	\$0	\$0	\$0	\$0	\$0	\$0
	NYS DOT	\$0	\$4,000	\$4,000	\$4,000	\$4,000	\$0	\$16,000
	FTA	\$0	\$32,000	\$32,000	\$32,000	\$32,000	\$0	\$128,000
	BNIA CAP RES	\$0	\$0	\$0	\$0	\$0	\$0	\$0
	TOTAL	\$190,000	\$115,000	\$80,000	\$90,000	\$90,000	\$0	\$565,000

NIAGARA FRONTIER TRANSPORTATION AUTHORITY
FIVE YEAR CAPITAL PLAN
FY 2011/12 - 2015/16

03/16/11

COST CENTER	FUNDING	2011/12	2012/13	2013/14	2014/15	2015/16	OUT YEARS	TOTAL
TOTAL CENTRAL ADMIN.								
NFTA		\$893,891	\$506,000	\$2,215,000	\$115,500	\$127,900	\$12,500	\$3,870,791
FTA		\$159,198	\$32,000	\$32,000	\$32,000	\$32,000	\$0	\$287,198
NYS DOT		\$19,900	\$4,000	\$4,000	\$4,000	\$4,000	\$0	\$35,900
88-C		\$136,754	\$93,000	\$93,000	\$93,000	\$93,000	\$0	\$508,754
TSGP ARRA		\$250,000	\$0	\$0	\$0	\$0	\$0	\$250,000
BNIA CAP RES		\$0	\$0	\$0	\$0	\$0	\$0	\$0
TSGP SUP 08		\$0	\$0	\$0	\$0	\$0	\$0	\$0
TSGP 07		\$0	\$0	\$0	\$0	\$0	\$0	\$0
TSGP 08		\$777,227	\$0	\$0	\$0	\$0	\$0	\$777,227
TSGP 09		\$3,411,685	\$0	\$0	\$0	\$0	\$0	\$3,411,685
COUNTER TERR. GRANT		\$0	\$0	\$0	\$0	\$0	\$0	\$0
DHS 09		\$0	\$0	\$0	\$0	\$0	\$0	\$0
UASI		\$0	\$0	\$0	\$0	\$0	\$0	\$0
TOTAL		\$5,648,655	\$635,000	\$2,344,000	\$244,500	\$256,900	\$12,500	\$9,141,555

NIAGARA FRONTIER TRANSPORTATION AUTHORITY
FIVE YEAR CAPITAL PLAN
FY 2011/12 - 2015/16

03/16/11

COST CENTER	FUNDING	2011/12	2012/13	2013/14	2014/15	2015/16	OUT YEARS	TOTAL
GRAND TOTAL								
FTA		\$24,368,337	\$50,095,110	\$22,180,200	\$34,416,319	\$4,675,670	\$2,193,284	\$137,928,920
NYS DOT		\$4,245,687	\$9,955,787	\$11,658,294	\$6,769,830	\$4,021,625	\$5,470,182	\$42,121,405
NFTA		\$4,026,665	\$9,400,759	\$14,206,214	\$6,593,109	\$15,062,274	\$24,531,431	\$73,820,452
88-C		\$1,752,148	\$7,323,483	\$8,447,689	\$13,683,765	\$11,361,937	\$48,902,231	\$91,471,253
INSURANCE		\$0	\$0	\$0	\$0	\$0	\$0	\$0
PRIVATE		\$0	\$0	\$0	\$0	\$0	\$0	\$0
ESCO		\$0	\$0	\$0	\$0	\$0	\$486,202	\$486,202
FHWA		\$0	\$14,771,295	\$39,868,605	\$5,927,040	\$0	\$0	\$60,566,940
FAA		\$20,586,662	\$16,664,244	\$19,101,089	\$19,396,124	\$27,060,769	\$95,352,220	\$198,161,108
ADF		\$344,123	\$0	\$0	\$0	\$0	\$0	\$344,123
PFC		\$2,499,416	\$2,585,700	\$32,599,880	\$964,783	\$2,390,812	\$5,765,365	\$46,805,956
NATIONAL FUEL		\$0	\$0	\$0	\$0	\$0	\$0	\$0
PENDING GRANT		\$170,606	\$175,000	\$0	\$0	\$0	\$0	\$345,606
DHS		\$0	\$0	\$0	\$0	\$0	\$0	\$0
SPECIAL COND. 7		\$0	\$0	\$0	\$0	\$0	\$0	\$0
TAP RESTRICTED		\$0	\$0	\$0	\$0	\$0	\$0	\$0
FUTURE PFC		\$1,208,533	\$6,251,164	\$736,574	\$1,003,397	\$1,357,886	\$0	\$10,557,554
PROP CAP. RES.		\$0	\$0	\$0	\$0	\$0	\$0	\$0
BH CAP. RES.		\$0	\$0	\$0	\$0	\$0	\$0	\$0
PENDING PFC		\$0	\$0	\$0	\$0	\$0	\$250,000	\$250,000
NYS DTF		\$3,713,400	\$3,713,400	\$438,181	\$0	\$0	\$0	\$7,864,981
BNIA CAP. RES.		\$1,632,604	\$1,826,665	\$307,665	\$175,000	\$158,982	\$93,000	\$4,193,916
CITY OF BUFFALO		\$0	\$627,780	\$1,694,416	\$229,673	\$0	\$0	\$2,551,869
NYS DEC		\$4,646	\$0	\$0	\$0	\$0	\$0	\$4,646
TSGP ARRA		\$250,000	\$0	\$0	\$0	\$0	\$0	\$250,000
TSGP 07		\$0	\$0	\$0	\$0	\$0	\$0	\$0
TSGP 08		\$777,227	\$0	\$0	\$0	\$0	\$0	\$777,227
TSGP 09		\$3,411,685	\$0	\$0	\$0	\$0	\$0	\$3,411,685
DHS 10		\$300,000	\$0	\$0	\$0	\$0	\$0	\$300,000
NYTEC		\$176,196	\$12,754	\$64,551	\$0	\$0	\$0	\$253,501
AIP		\$27,413	\$0	\$0	\$0	\$0	\$0	\$27,413
PFC (MATCH)		\$4,571	\$0	\$0	\$0	\$0	\$0	\$4,571
NYS AIR 99		\$0	\$0	\$0	\$0	\$0	\$0	\$0
ECC		\$0	\$0	\$0	\$0	\$0	\$0	\$0
BOND		\$0	\$561,367	\$7,910,504	\$1,995,000	\$13,472,812	\$13,472,812	\$37,412,495
TSA		\$0	\$0	\$0	\$0	\$0	\$1,500,000	\$1,500,000
UASI		\$0	\$0	\$0	\$0	\$0	\$0	\$0
CITY OF NF		\$0	\$0	\$0	\$0	\$0	\$0	\$0
NFIA CAP RES		\$0	\$0	\$0	\$0	\$0	\$0	\$0
SEN BACKED LOAN		\$0	\$0	\$0	\$0	\$0	\$0	\$0
NYS MOU		\$0	\$0	\$0	\$0	\$0	\$0	\$0
TSGP SUP 08		\$0	\$0	\$0	\$0	\$0	\$0	\$0
COUNTER TERR. GRANT		\$0	\$0	\$0	\$0	\$0	\$0	\$0
NYS		\$0	\$0	\$0	\$0	\$0	\$0	\$0
AIRFORCE		\$362,767	\$4,779,911	\$0	\$0	\$0	\$0	\$5,142,678
FUTURE FUNDING		\$1,494,444	\$20,494,787	\$3,781,140	\$95,000	\$0	\$0	\$25,865,371
ECONOMIC DEV		\$0	\$0	\$0	\$0	\$0	\$0	\$0
DHS 09		\$0	\$0	\$0	\$0	\$0	\$0	\$0
TOTAL		\$71,357,130	\$149,239,206	\$162,995,002	\$91,249,040	\$79,562,767	\$198,016,727	\$752,419,872

NIAGARA FRONTIER TRANSPORTATION AUTHORITY

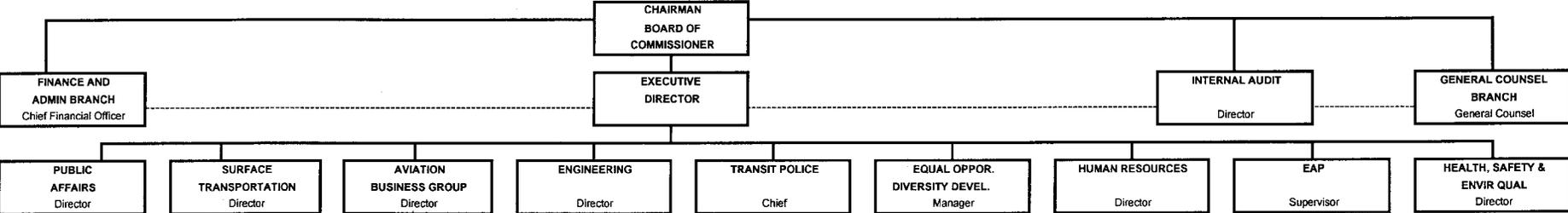

TOTAL EMPLOYEES:

	FT	PT	TOTAL
NFTA	494	1	495
METRO	1,100	2	1,102
TOTAL	1,594	3	1,597

NIAGARA FRONTIER TRANSPORTATION AUTHORITY
(\$000's)

	METRO	TRANSP CTRS	SURFACE TRANSP GROUP SUBTOTAL	BNIA	NFIA	AIRPORT BUSN GROUP SUBTOTAL	PROP MGMT	CENTRAL ADMIN	FYE12 CONSOL TOTAL	FYE11 ADOPTED BUDGET	VARIANCE	% VARIANCE	
REVENUES & ASSISTANCE													
Operating Revenues													
Airport Fees & Services	0	0	0	16,459	49	16,507	0	0	16,507	15,590	917	5.9%	1
Passenger Fares	32,004	0	32,004	0	0	0	0	0	32,004	30,322	1,681	5.5%	2
Boat Harbor Fees	0	0	0	0	0	0	973	0	973	866	108	12.4%	3
Rental Income	0	1,705	1,705	9,069	141	9,210	2,788	0	13,703	13,723	-20	-0.1%	4
Concessions/Commissions	0	68	68	28,473	854	29,327	66	0	29,460	28,399	1,062	3.7%	5
Retail Sales	0	0	0	0	0	0	275	0	275	240	35	14.6%	6
Resales & Rebillings	0	5	5	1,416	16	1,433	301	0	1,738	1,733	5	0.3%	7
Other Operating Revenues	<u>782</u>	<u>0</u>	<u>782</u>	<u>3,077</u>	<u>87</u>	<u>3,164</u>	<u>0</u>	<u>0</u>	<u>3,947</u>	<u>3,776</u>	<u>170</u>	<u>4.5%</u>	<u>8</u>
	32,786	1,778	34,564	58,494	1,147	59,641	4,402	0	98,607	94,649	3,958	4.2%	
Operating Assistance													
Local	4,100	0	4,100	0	0	0	0	0	4,100	4,100	0	0.0%	9
Erie County Sales Tax	17,632	0	17,632	0	0	0	0	0	17,632	16,931	701	4.1%	10
Mortgage Tax	7,233	0	7,233	0	0	0	0	0	7,233	7,246	-13	-0.2%	11
Local - 88c Funds	8,971	0	8,971	0	0	0	0	0	8,971	8,170	801	9.8%	12
Peace Bridge	200	0	200	0	0	0	0	0	200	200	0	0.0%	13
State - Local Match	4,100	0	4,100	0	0	0	0	0	4,100	4,100	0	0.0%	14
State - MTOAF	24,809	0	24,809	0	0	0	0	0	24,809	24,809	0	0.0%	15
State - Sec 9 ACM	43	0	43	0	0	0	0	0	43	43	0	0.0%	16
State - DMTTF	7,569	0	7,569	0	0	0	0	0	7,569	7,569	0	0.0%	17
State - General Fund - AMTAP	5,529	0	5,529	0	0	0	0	0	5,529	5,529	0	0.0%	18
State - Sec 9 PMA	1,201	0	1,201	0	0	0	0	0	1,201	1,201	0	0.0%	19
State - Paratransit	213	0	213	0	0	0	0	0	213	213	0	0.0%	20
State - CST	80	0	80	0	0	0	0	0	80	80	0	0.0%	21
Federal - Sec 18	49	0	49	0	0	0	0	0	49	49	0	0.0%	22
Federal - Sec 9 ACM	345	0	345	0	0	0	0	0	345	345	0	0.0%	23
Federal - PMA	9,611	0	9,611	0	0	0	0	0	9,611	9,611	0	0.0%	24
Federal - Paratransit	1,700	0	1,700	0	0	0	0	0	1,700	1,700	0	0.0%	25
Federal - New-Freedom Initiative	150	0	150	0	0	0	0	0	150	150	0	0.0%	26
Federal - JARC	200	0	200	0	0	0	0	0	200	200	0	0.0%	27
Federal Operating Assistance	0	0	0	0	0	0	0	309	309	779	-470	-60.4%	28
Federal - K-9 Cops	0	0	0	0	0	0	0	0	0	209	-209	-100.0%	29
Federal - DEA Expenditures	0	0	0	0	0	0	0	0	0	0	0	n/a	30
Federal - DEA OT Reimbursement	0	0	0	0	0	0	0	16	16	16	0	0.0%	30
Federal - TSGP	<u>0</u>	<u>0</u>	<u>0</u>	<u>0</u>	<u>0</u>	<u>0</u>	<u>0</u>	<u>0</u>	<u>0</u>	<u>36</u>	<u>-36</u>	<u>-100.0%</u>	<u>31</u>
Total Operating Assistance	93,735	0	93,735	0	0	0	0	325	94,060	93,285	775	0.8%	
TOTAL OPERATING REV & ASST	126,521	1,778	128,298	58,494	1,147	59,641	4,402	325	192,667	187,935	4,732	2.5%	

NIAGARA FRONTIER TRANSPORTATION AUTHORITY
(\$000's)

	METRO	TRANSP CTRS	SURFACE TRANSP GROUP SUBTOTAL	BNIA	NFIA	AIRPORT BUSN GROUP SUBTOTAL	PROP MGMT	CENTRAL ADMIN	FYE12 CONSOL TOTAL	FYE11 ADOPTED BUDGET	VARIANCE	% VARIANCE	
OPERATING EXPENSES (Excluding Depreciation)													
Personnel Services	85,989	1,403	87,393	13,148	1,446	14,594	656	27,897	130,540	128,325	2,215	1.7%	32
Maintenance & Repairs	6,754	188	6,942	8,747	900	9,647	433	308	17,331	17,167	163	1.0%	33
Transit Fuel Power	8,620	0	8,620	0	0	0	0	0	8,620	6,309	2,312	36.6%	34
Utilities	2,463	508	2,971	2,675	383	3,058	639	51	6,720	6,197	523	8.4%	35
Insurance & Injuries	3,019	26	3,045	494	108	603	144	172	3,964	4,055	-91	-2.3%	36
Safety & Security	372	0	372	728	39	767	8	81	1,228	1,419	-190	-13.4%	37
General Business/Other	11,222	893	12,115	6,386	588	6,974	734	2,272	22,096	22,481	-385	-1.7%	38
Administrative Cost Reallocation													
Administrative Cost	3,713	384	4,096	2,870	655	3,525	1,061	-8,683	0	0	0	n/a	39
Police Cost	4,649	464	5,113	4,690	300	4,990	72	0	10,174	9,557	617	6.5%	40
Costs Transferred to Cap'l Projects	-10	0	-10	-92	0	-92	0	-2,361	-2,464	-1,890	-573	30.3%	41
Inter Division Reimbursement	0	-1,187	-1,187	-1,769	0	-1,769	0	-19,412	-22,368	-22,224	-143	0.6%	42
TOTAL OPERATING EXPENSES	126,791	2,680	129,470	37,878	4,420	42,298	3,748	325	175,841	171,395	4,446	2.6%	
OPERATING INCOME/(LOSS)	-270	-902	-1,172	20,616	-3,273	17,343	655	0	16,825	16,540	286	1.7%	
NON-OPERATING ITEMS													
Bond Debt Service	0	0	0	-14,153	0	-14,153	0	0	-14,153	-14,284	131	-0.9%	43
Operating Expense Reserve & R&R Rsv	0	0	0	-294	0	-294	0	0	-294	-213	-81	38.0%	44
Debt Service - Glycol Collection	0	0	0	-300	0	-300	0	0	-300	-305	5	-1.5%	45
Property Management Debt Service	0	0	0	0	0	0	-266	0	-266	-300	34	-11.3%	46
Debt Service - Noresco	-310	-64	-374	-273	0	-273	0	0	-647	-646	0	0.0%	47
NFIA Contribution (Excluding Debt Service)	0	0	0	-1,670	0	-1,670	0	0	-1,670	-1,653	-17	1.0%	48
BNIA Contribution (Excluding Debt Svc)	0	0	0	0	1,670	1,670	0	0	1,670	1,653	17	1.0%	49
NFIA Contribution - Debt Service	0	0	0	-2,092	0	-2,092	0	0	-2,092	-2,180	88	-4.0%	50
BNIA Contribution - Debt Service	0	0	0	0	2,092	2,092	0	0	2,092	2,180	-88	-4.0%	51
ADF NFIA Debt Service Funding	0	0	0	1,000	0	1,000	0	0	1,000	1,000	0	0.0%	52
Debt Service	0	0	0	0	-2,092	-2,092	0	0	-2,092	-2,180	88	-4.0%	53
Intercompany Transfer - Metro	-700	0	-700	0	0	0	0	0	-700	-780	80	-10.2%	54
Intercompany Transfer - Tr Centers	0	700	700	0	0	0	0	0	700	780	-80	-10.2%	55
Interest Income	12	0	12	250	0	250	0	0	262	402	-140	-34.8%	56
Entitlements	0	0	0	1,000	0	1,000	0	0	1,000	0	1,000	n/a	57
PFC	0	0	0	2,692	0	2,692	0	0	2,692	2,692	0	0.0%	58
TOTAL NON-OPERATING ITEMS	-998	636	-362	-13,841	1,670	-12,171	-266	0	-12,799	-13,835	1,036	-7.5%	
NET INCOME/(LOSS)	-1,268	-266	-1,534	6,775	-1,603	5,172	389	0	4,027	2,705	1,322	48.9%	
LESS: DIRECT CAPITAL	2,051	563	2,614	0	0	0	519	894	4,027	2,705	1,322	48.9%	59
LESS: INDIRECT CAPITAL	382	40	422	295	67	363	109	-894	0	0	0	n/a	
NET SURPLUS/(DEFICIT)	-3,701	-869	-4,569	6,479	-1,670	4,809	-240	0	0	0	0	n/a	

ORGANIZATION OF THE BUDGET DOCUMENT

The NFTA operating and capital budget is presented under eight sections.

- The first section, Executive Summary, contains the Chief Financial Officer's Budget Message and Summary. The message outlines overall revenue projections, spending priorities, operational goals, and capital needs.
- The second section, Budget Overview, outlines the organization of the budget document and contains key revenue and expenditure indicator assumptions used to form the financial plan. Each footnoted key indicator of the summary page 1-1 corresponds to the numbered explanations of this section.
- The third through sixth sections, Surface Transportation, Aviation, Property Group and Central Administration Budgets, are organized by business center and branches making up the central administration respectively. Included for each business center and branch is an organization chart, a line item revenue and expense consolidated cash flow surplus/(deficit) summary statement by business center or branch, a narrative, a detail line item revenue and expense summary by cost center, detailed personnel schedules, and capital budgets. All Central Administration branches, with the exception of General Counsel and Engineering include some cost centers within departments which are part of Metro reporting but, by function, belong with the branch. For legal and/or accounting purposes, these Metro cost centers must be recorded separately from the Authority. Where appropriate, the Metro portion of revenues and expenditures have been identified separately from the Authority.
- The financial net surplus/(deficit) summary statement provides FY 09-10 actuals and a comparison of the FY 10-11 budget vs FY 11-12 budget.
- The narrative includes: the business center or support unit description, purpose, responsibilities, services, program and service objectives, key performance indicators and key changes in operations or budgets.

- The detail line item revenue and expense summary provides actual revenues received and expenditures for FY 2009-10, the current annual budget, the FY 2010-11 December year-to-date actual, the FY 2011-12 recommended budget and the variance from the prior budget.
- The detailed personnel schedules follow the detail line item revenue and expense summary. This includes the base salary, the non-represented compensation pool, union increases, longevity pay, and the scheduled amount, which is the recommended FYE 12 appropriation.
- Capital budgets follow each business center.

SUMMARY OF REVENUES AND EXPENDITURES

The NFTA consolidated operating budget is prepared on a basis that parallels the NFTA's accounting systems. Budget summaries are prepared by grouping categories of revenues and expenditures under meaningful headings designated as business centers. Financial statements are prepared using the accrual basis of accounting. The financials of the NFTA are prepared in conformity with governmental accounting and financial reporting principles of the Governmental Accounting Standards Board.

The financial transactions of the NFTA are accounted for under two enterprise funds which are titled the Authority and Metro. The Authority includes the activities of Metropolitan Transportation Centers, the airports, various properties and facilities and related administrative support. Metro includes all the activities of the bus and rail system. The operating budget is organized on a departmental basis within these two funds and is oriented for expenditure control and accountability.

AUTHORITY REVENUE ASSUMPTIONS **(Footnote Numbers From Page 1-1)**

1. AIRPORT FEES & SERVICES

Airport Fees & Services revenue comprises 28.1% of total Buffalo Niagara International Airport Revenues and are increasing \$907k, or 5.8%, due to higher compensatory direct and indirect landing area expenses, decreases in interest income offsetting these higher expenses, higher operating expense reserves, and an increase in our general aviation revenue, more in line with our FYE 11 forecast. These increases were partially offset by a lower NFIA net deficit (BNIA signatory airlines reimburse the NFTA for 50% of NFIA's net deficit). NFIA Airport Fees & Services are also a source of revenue at our Niagara Falls International Airport and comprise 4.2% of total revenues at that airport. Combined, this source of revenue is projected at 16.7% of all Authority FYE 12 revenues.

The BNIA landing fee rate is calculated on a cost recovery formula based on budgeted expenses applied to gross landing weight. In addition to budgeted expenses, the FYE 12 landing fee rate reflects signatory airline billings for debt service and operating reserves under the 1998, 1999, 2000 and 2004 Airport Revenue Bonds.

3. BOAT HARBOR FEES

The NFTA Boat Harbor business center is open for operation five months of the year and currently has 1,005 boat slips. FYE 12 Dock Rental revenue is anticipated to increase \$71k, or 9.0% above FYE 11.

4. RENTAL INCOME

Building space and other rentals are a source of revenue for each of the Authority business centers. These are space and land occupancy fees charged to tenants. NFIA Rental Income is \$25k, or 15.2%, below FYE 11, due to lower than anticipated rental revenues at the former NFIA terminal. Property Management Rental Income is \$133k, or 5.0%, above FYE 11 due to new tenants at our 485 Cayuga facilities. Our Transportation Centers are decreasing \$88k, or 4.9%, more in line with our FYE11 forecast of office space rental fees.

5. CONCESSIONS/COMMISSIONS

The fees charged to tenants for the right to sell their goods and services to the public or to use NFTA premises to sell their products is a source of revenue for most business centers. These types of services and products range from parking lot services and car rental services to food and beverage sales and video games. BNIA Concessions/Commissions are increasing \$535k, or 1.9%, due to a 2% increase in enplanements and contractual increases with our auto rental tenants. NFIA is increasing \$490k, or 134.7%, due to anticipated higher parking lot revenue with our anticipated increase in business activity.

6. RETAIL SALES

The source of this revenue is predominately the receipts from the sale of gas at our NFTA Boat Harbor facility.

7. REALES & REBILLING

The charges to customers for their share of utility usage is categorized as resales & rebillings. Property Management is increasing \$9k, or 3.2%, as a result of anticipated higher commodity costs.

8. OTHER OPERATING REVENUES

The primary source of this revenue is direct billing to our BNIA airlines for the new baggage handling system. BNIA is increasing \$300k, or 10.8%, due to a increase in direct airline billings for maintenance costs in the operation of our baggage handling system.

METRO REVENUE ASSUMPTIONS
(Footnote Numbers From Page 1-1)

2. PASSENGER FARES

Total passenger fare revenue (from public transit usage) for FYE 12 is expected to increase \$1,681k, or 5.5%, more in line with our FYE 11 forecast and includes funds for the Buffalo Niagara Medical Campus initiative.

8. OTHER OPERATING REVENUES

This consists chiefly of the receipts from bus and rail advertising and is decreasing \$172k, or 18.0%.

OPERATING ASSISTANCE
(Footnote Numbers From Page 1-1)

9. - 13. LOCAL OPERATING ASSISTANCE

Total anticipated local operating assistance for FYE 12 is \$37,530k, and is comprised of the following:

	FYE 12 <u>(000's)</u>
Erie County Sales Tax	\$17,632
Mortgage Recording Tax	7,233
88(c)	8,971
Erie County match to 18(b)	3,657
Niagara County match to 18(b)	443
Peace Bridge	<u>200</u>
	<u>\$38,136</u>

14. - 21. STATE OPERATING ASSISTANCE

New York State operating assistance includes funding primarily for our Metro operations made available through the Public Transportation Operation Assistance Fund and miscellaneous other grants.

FYE 11
(000's)

Public Transportation Operation Assistance Funds	37,907
18(b)	4,100
Miscellaneous Other Grants	<u>1,537</u>
	<u>\$43,544</u>

Section 18(b) funding is matched by mandate by Erie and Niagara County Counties.

22. - 31. FEDERAL OPERATING ASSISTANCE

Total Federal assistance of \$12,380k is \$715k, or 5.5%, lower than FYE 11 levels. FYE 12 includes a reclassification of transit police operating assistance funds reflective of our FYE 11 forecast.

KEY EXPENDITURE ASSUMPTIONS
(Footnote Numbers From Page 1-2)

Key expenditure indicators can be summarized on an NFTA-wide basis since the characteristics of the expenditures are similar to each fund.

32. PERSONNEL SERVICES

Salaries

The FYE 12 budget has a net increase of 12 full time employees offset by a decrease of 1 part time employee due to restoration of Metro service levels and alleviation of capacity issues, partially offset by early retirement savings. FYE 12 includes union cost increases reflective of labor agreements, cost neutral contracts proposed for those that will expire and 0% wage increases for non-represented employees.

Benefits

Paid employee benefits are budgeted at 49.0% of salaries for Authority employees and 70.4% of salaries for Metro employees. Fringe benefits are calculated for all NFTA employees in accordance with the various collective bargaining agreements and/or government mandate. Those

paid benefits are as follows:

Pensions

All Authority employees are eligible for membership in the New York State Employees Retirement System (NYSERS). Employees who joined the system prior to July 23, 1976 or joined after July 23, 1976 with ten years experience and the Transit Police are in a non-contributory plan. Employees who joined after July 23, 1976 with less than ten years experience and belong to Tier III or Tier IV are required to contribute 3% of their compensation to the plan. Authority contribution is estimated to be 17.1% of employee compensation for FYE 12, Authority pension numbers factor in early retirement incentive costs and are \$481k, or 10.3% above FYE11.

All full-time Metro employees who are union members are covered by a contributory single employer defined contribution pension plan. All full-time Metro employees contribute 4% of their pay to the plan, the Metro current contribution is 11%.

Social Security Tax

The Authority and Metro contribution to the Federal Social Security System is calculated using an effective rate of 7.65% of salaries. Salaries of \$106,800 and higher are subject to a 1.45% Medicare portion of FICA only.

Workers' Compensation

Due to double digit premium increases, the Authority became self-insured for workers' compensation coverage in mid FYE 91. The appropriation for the expense provides funding for medical and indemnity payments, mandated state assessments, administration fees and third party administrator fees. A worker's compensation team within the Risk Management department helps manage our worker's compensation cases. Worker's Compensation costs are increasing \$1,243k, or 20.2%, based on recent trends.

Medical and Hospitalization Insurance

The FYE 12 budget anticipates a decrease in our health insurance costs of \$243k, or 1.1%, as our favorable experience rating mitigates an anticipated 5.0% rate hike.

Dental and Optical Insurance

Dental insurance and optical is provided through GHI. The FYE 12 budget for this is based on current rates per covered payroll and includes \$223k in savings resulting from the transfer in administration of the plan from GHI to LMHF.

Unemployment Insurance

Financial exposure results if unemployment costs are not controlled. The NFTA is self insured for unemployment insurance. The FYE 12 budget is based on historical experience factored with our FYE 11 costs.

Group Life Insurance

All Metro employees and non-union Authority employees are provided group life insurance. All Authority employees who fall under the New York State retirement system are provided basic life insurance coverage through that plan. The FYE 12 budget for group life insurance is based on current rates per covered payroll and adjusted for a possible rate increase during the fiscal year.

Disability Insurance

The NFTA is self insured for disability benefits. The FYE 12 budget for disability expense is based on historical experience factored with the 2011 payment structure.

Long Term Disability Insurance

All non-represented employees are provided long term disability insurance. The FYE 12 budget for this coverage is based on current rates per covered payroll and adjusted for a possible rate increase during the fiscal year.

33. MAINTENANCE & REPAIRS

The routine expense of maintenance and operation of the NFTA's buildings, equipment, buses and rail cars comprise 9.9% of the total Authority FYE 12 budget. Total FYE 12 costs of \$17,331k are \$163k, or 1.0%, above FYE 11. BNIA's Maintenance & Repairs are increasing \$168k, or 2.0%, due to higher runway and parking lot rehab costs and increasing terminal HVAC/elevator/escalator repair expenses. NFIA is increasing \$58k, or 6.9%, due to the allocation of a dedicated BNIA facilities maintenance department staff person.

34. TRANSIT FUEL POWER

Diesel fuel to run buses and electric power to run the rail cars comprise 5.3% of the total Metro budget. Total FYE 12 costs of \$8,620k are \$2,312, or 36.6%, above FYE 11. FYE 12 budget anticipates \$3.10/gal #2 ULSD diesel fuel, FYE 11 actual market prices have ranged from a low of \$2.00/gal on 07/05/2010 to a high of \$3.30/gal on 2/28/11.

35. UTILITIES

FYE 12 utilities of \$6,720k are \$523k, or 8.4%, above FYE 11. Metro is increasing \$238k, or 10.7%, more in line with our FYE 11 forecast. BNIA expenses are increasing \$248k, or 10.2%, more in line with our FYE 11 forecast as costs associated with our new baggage handling system are well established.

36. INSURANCE AND INJURIES

The Authority purchases property insurance then assumes the liability for most risks including, but not limited to, property damage and personal injury claims. NFTA also purchases insurance for most risks such as airport liability, excess liability, police professional liability and property and is self insured for public property damage and personal injury at our Transportation Centers.

The Insurance and Injuries category records the expense of investigation and settlement of annual routine claims as well as the cost of purchased insurance.

Lower claim losses, as a result of a downward trend in accidents contributes to an overall decrease of \$91k, or 2.3%, in our costs.

37. SAFETY & SECURITY

The Authority provides secondary security services through an outside service that provides support at Buffalo Niagara International Airport, Niagara Falls International Airport and guard service at the Metro Rail Yard and Shop Station. FYE 12 costs of \$1,228k are \$190k, or 13.4%, below FYE 11, more in line with our FYE 11 forecast reflective of cost control initiatives.

38. GENERAL BUSINESS/OTHER

General business expenses include non-employees, communications, office supplies, business travel, consultant fees, contingencies, management fees, payments in lieu of taxes, employee training and printing & advertising. FYE 12 costs of \$22,096k are \$385k, or 1.7%, below FYE 11. Metro's expenses are decreasing \$227k, or 2.0%, as a result of lower Metro management fees due to early retirement savings. Additionally, Central Administration costs are \$294k, or 11.5%, below FYE 11 due to lower general office and professional service costs. NFIA's expenses are increasing \$102, or 21.0%, due to higher parking lot expenses based on anticipated increased business activity.

39. OVERHEAD COST ALLOCATION - ADMINISTRATIVE COSTS

The current administrative cost allocation formula is as follows:

BNIA	33.1%
NFIA	7.5%
Transportation Centers	4.4%
Property Management	12.2%
Metro	42.8%
TOTAL	<u>100.0%</u>

40. OVERHEAD COST ALLOCATION - POLICE COST

The Authority maintains a Transit Police force which provides pro-active security for all NFTA/NFT Metro facilities. The oversight responsibility for the Transit Police force rests within the Executive Branch. For accounting purposes, this unit is recorded in Central Administration on the appropriate expense lines. To the extent that costs are incurred in support of BNIA, Metro, MTC or Property Management, those business centers absorb the appropriate costs in the Safety & Security category. The cost of these services, are reimbursed to Central Administration on the Inter-Division Reimbursement line.

FYE 12 police costs are increasing \$617k, or 6.5%, due to an increase in police pension and workers' compensation costs, partially offset by a decrease in health insurance costs.

41. DIRECT COSTS TRANSFERRED TO CAPITAL PROJECTS

The Authority receives capital grants from FTA, FAA and New York State for the purpose of procurement and construction of major assets to support operations. As staff time commitments and administrative expense related to these non-operating projects accumulate, the Authority operating expenses are equally offset by the project funding. FYE 12 Direct Costs Transferred to Capital Projects of \$2,464k are \$573k, or 30.3%, above FYE 11, as FYE 12 includes a transit police reclassification of funds previously recognized as operating assistance.

42. INTER DIVISION REIMBURSEMENT

The Authority accounts for specific functions and services of staff that can be directly expensed to other divisions and units. This results in an offset to the appropriate departments on a separate reimbursement line. FYE 12 Inter Division Reimbursement of \$22,368k is \$143k, or 0.6%, above FYE 11. This is primarily attributable to higher police pension and workers' compensation costs partially offset by lower police health insurance costs and a decrease in the Metro management fee allocation due to early retirement savings.

43. BOND DEBT SERVICE

The debt service under the 1998, 1999, 2000 & 2004 Airport Revenue Bonds.

44. OPERATING EXPENSE RESERVE

The operating reserve of (\$294k) represents the amount needed to maintain our two-month BNIA operating expense reserve fund as outlined in the bond resolution.

45. DEBT SERVICE – GLYCOL COLLECTION

BNIA debt service related to the installation of the glycol collection system.

46. DEBT SERVICE – PROPERTY MGMT

The debt service related to the refinancing of our Terminal A facility loan.

47. DEBT SERVICE – NORESCO

The debt services related to NFTA/Metro energy initiatives.

48. NFIA CONTRIBUTION (Excluding Debt Service)

This is the BNIA signatory contribution, excluding debt service, to 50% of NFIA's deficit, this amount is included in BNIA revenues under Airport Fees & Services.

49. BNIA CONTRIBUTION (Excluding Debt Service)

This is the contribution from the BNIA signatory airlines, excluding debt service, representing 50% of NFIA's deficit.

50. NFIA CONTRIBUTION – Debt Service

The debt service related to the construction of the new NFIA Terminal, exclusive from BNIA signatory contribution.

51. BNIA CONTRIBUTION – Debt Service

This is the contribution from BNIA for the debt service related to the construction of the new NFIA Terminal.

52. ADF NFIA DEBT SERVICE FUNDING

Partial funding for the NFIA debt service.

53. DEBT SERVICE

The debt service related to the construction of the new NFIA Terminal, exclusive from BNIA signatory contribution.

54. INTERCOMPANY TRANSFER - METRO

This is the contribution of Metro to our Transportation Centers for Metro related operating and capital costs.

55. INTERCOMPANY TRANSFER - TRANSPO CTRS

This is the receipt of funds from Metro for Metro related operating and capital costs.

56. INTEREST INCOME

This is interest income on NFTA deposits, primarily BNIA related.

57. ENTITLEMENTS

Funds allocated to offset NFIA terminal debt service costs. Eligibility of these funds, allocated based on FAA's discretion, are based on NFIA meeting the 10,000 yearly passenger threshold guideline.

58. PFC

PFC stands for passenger facility charge and is a source of the Airport Improvement Program (AIP) funding.

59. DIRECT CAPITAL

This is the NFTA equity funded portion of our projected FYE 12 capital expenditures.

SURFACE TRANSPORTATION BUSINESS GROUP

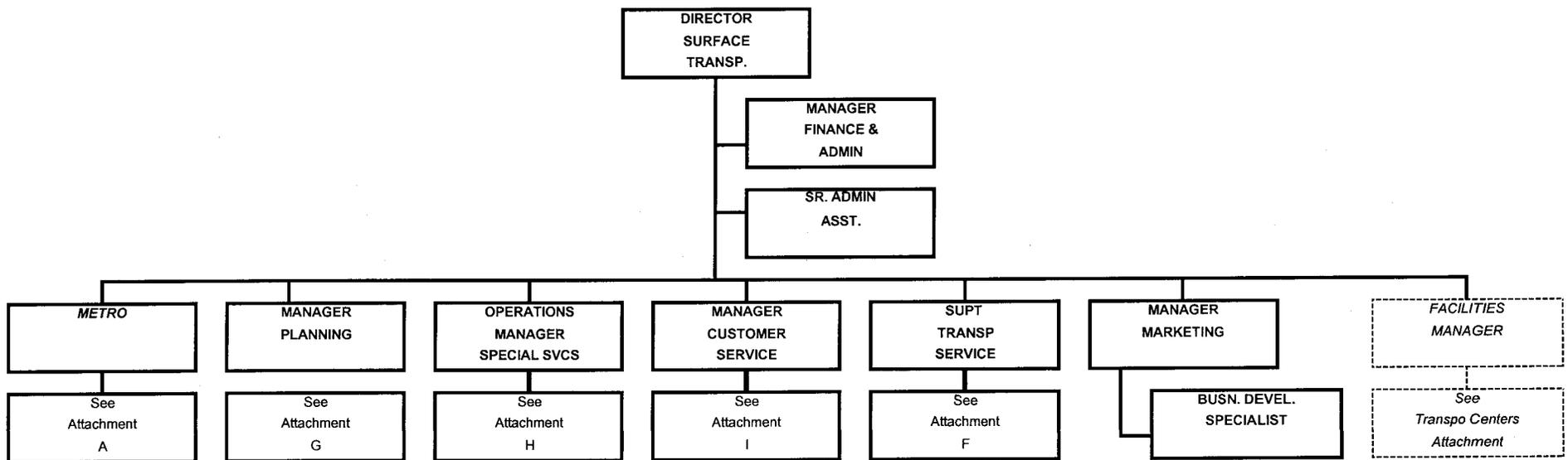

TOTAL EMPLOYEES:
NFTA

9

METRO CONSOLIDATED

2010/11 ANNUAL BUDGET

VS

2011/12 ANNUAL BUDGET

	FY 09-10 ACTUAL	FY 10-11 BUDGET	FY 11-12 BUDGET	VARIANCE	%
REVENUES & ASSISTANCE					
Operating Revenues					
Passenger Fares	30,661,752	30,322,158	32,003,500	1,681,342	5.5%
Other Operating Revenues	901,512	954,160	782,449	-171,711	-18.0%
Total Revenues	31,563,264	31,276,318	32,785,949	1,509,631	4.8%
Operating Assistance					
Local	4,100,000	4,100,000	4,100,000	0	0.0%
Erie County Sales Tax	16,598,865	16,930,841	17,632,117	701,276	4.1%
Mortgage Tax	7,458,654	7,245,553	7,232,999	-12,554	-0.2%
Local - 88c Funds	4,965,845	8,170,085	8,971,000	800,915	9.8%
Peace Bridge	200,000	200,000	200,000	0	0.0%
State - Local Match	4,100,000	4,100,000	4,100,000	0	0.0%
State - MTOAF	25,369,000	24,809,000	24,809,000	0	0.0%
State - Sec 9 ACM	43,464	43,072	43,072	0	0.0%
State - DMTTF	7,569,000	7,569,000	7,569,000	0	0.0%
State - General Fund - AMTAP	5,529,000	5,529,000	5,529,000	0	0.0%
State - Sec 9 PMA	1,201,378	1,201,377	1,201,377	0	0.0%
State - Paratransit	212,500	212,500	212,500	0	0.0%
State - CST	60,431	80,000	80,000	0	0.0%
Federal - Sec 18	38,800	49,000	49,000	0	0.0%
Federal - Sec 9 ACM	347,775	344,613	344,613	0	0.0%
Federal - PMA	9,611,024	9,611,020	9,611,020	0	0.0%
Federal - Paratransit	1,700,000	1,700,000	1,700,000	0	0.0%
Federal - New-Freedom Initiative	150,000	150,000	150,000	0	0.0%
Federal - JARC	0	200,000	200,000	0	0.0%
Total Operating Assistance	89,255,736	92,245,061	93,734,698	1,489,637	1.6%
				0	n/a
TOTAL OPER REVS & ASST	120,819,000	123,521,379	126,520,647	2,999,268	2.4%
OPERATING EXPENSES (Excl. Depr.)					
Personnel Services	82,398,053	84,048,969	85,989,488	1,940,519	2.3%
Maintenance & Repairs	6,744,250	6,698,129	6,753,986	55,857	0.8%
Transit Fuel/Power	7,678,210	6,308,830	8,620,332	2,311,502	36.6%
Utilities	2,148,905	2,224,374	2,462,780	238,406	10.7%
Insurance & Injuries	2,157,829	3,135,313	3,018,635	-116,678	-3.7%
Safety & Security	5,639,817	4,602,143	5,020,689	418,546	9.1%
General Business/Other	10,829,110	11,449,599	11,222,442	-227,157	-2.0%
Administrative Cost Reallocation	3,830,414	3,989,832	3,712,681	-277,152	-6.9%
Costs Transferred to Capital Projects	-30,412	0	-10,155	-10,155	n/a
Inter Division Reimbursement	0	0	0	0	n/a
TOTAL OPERATING EXPENSES	121,396,176	122,457,189	126,790,878	4,333,688	3.5%
OPERATING INCOME/(LOSS)	-577,176	1,064,190	-270,231	-1,334,420	-125.4%
NON-OPERATING ITEMS					
Debt Service - Noresco	-261,694	-309,524	-309,524	0	0.0%
Interest Income	0	27,000	12,000	-15,000	-55.6%
Intercompany Transfer	-633,207	-779,838	-700,000	79,838	-10.2%
TOTAL NON-OPERATING ITEMS	-894,901	-1,062,362	-997,524	64,838	-6.1%
NET INCOME/(LOSS)	-1,472,077	1,828	-1,267,755	-1,269,582	-69456.6%
LESS: DIRECT CAPITAL	606,516	592,665	2,050,903	1,458,238	246.0%
LESS: INDIRECT CAPITAL	170,755	266,494	382,228	115,734	43.4%
NET SURPLUS/(DEFICIT)	-2,249,348	-857,331	-3,700,885	-2,843,554	331.7%

SURFACE TRANSPORTATION

DESCRIPTION

The Surface Transportation Business Unit is responsible for all ground-based transportation services operated and provided by NFTA. Such services include fixed-route bus and rail routes, paratransit and other non-traditional transit services, and intercity bus terminals in Buffalo and Niagara Falls. Surface Transportation units include Metro (fixed-route bus and rail), Marketing, Service Planning, Special Services (paratransit and MetroLink), Transportation Centers (bus terminals and Central Services), and Customer Service.

The mission of the Surface Transportation Business Unit is to enhance the quality of life of residents and visitors by providing the highest level of safe, clean, affordable, responsive and reliable transportation through a coordinated and convenient bus and rail system. Our vision is to support the effective coordination and partnership with public and private entities in continuously improving transportation services to promote regional growth. The range of mobility services we will provide includes traditional bus and rail lines, circulator routes, employer shuttles, paratransit, bicycle programs and pedestrian enhancements. Our goal is to achieve a reputation as the best transit system in the United States.

1.0 METRO

Metro provides comprehensive fixed-route urban and suburban public transportation services within the Erie and Niagara county service area. Metro's 324 fixed-route big buses, 64 Paratransit/MetroLink small buses and 27 rail cars operate up to 22 hours per day, seven days per week, to serve the residents of the urbanized area. There are 78 bus routes on which Metro operates nearly 14.4 million annual bus miles, and one rail route on which 962,000 annual car miles are operated. Each weekday Metro carries approximately 93,500 passengers on buses and trains. In FYE 10, 26,800,000 customers used Metro.

Metro consists of two operating divisions, Bus and Rail. Metro Bus consists of three operating locations, Bus Transportation Service and

Bus Maintenance. Metro Rail encompasses one operating location, Rail Transportation Service and Rail Maintenance. In addition, the Transportation Support department is included within Metro. There are approximately full-time and part-time budgeted positions in these units.

It is the primary responsibility of each operating location to provide service to the public as scheduled. This involves managing a properly trained workforce of transportation and maintenance employees of an adequate, cost-effective size; monitoring and enhancing the quality of service; and adjusting service as required to accommodate service needs.

The Transportation Service Departments in the Bus and Rail divisions are responsible for supervising transit service and control center operations. Their functions include the continuous monitoring of service delivery with corrective action when problems occur, responding to emergencies, providing service to special events, coordinating transit service with construction projects, and communicating with operators and maintenance personnel.

Major Bus Maintenance activities are performed at the Cold Spring Shop. Such activities include major component change-out, bodywork, painting, engine and transmission rebuilding, parts reconditioning and structural repairs, radio maintenance and farebox maintenance. Shop employees also maintain the bus garage facilities, bus stop signs and bus loops.

Maintenance of the rail physical infrastructure is the responsibility of Metro Rail Maintenance. Among the physical plant elements that require a high level of ongoing maintenance are the track, communications systems, fare collection system, ventilation system, train control system, the electrical distribution system, and the stations and tunnels.

The Transportation Support Department is responsible for new operator training, oversight of the bus communications system, and the issuance of system operating notices.

2.0 MARKETING

The Marketing Department is responsible for developing goals and implementing strategies and programs to increase customer utilization and satisfaction of services. Staff works with businesses, schools, agencies and the public to determine customer needs, and provides feedback to Service Planning to help in the design of service.

3.0 SERVICE PLANNING

The Service Planning function ensures that convenient, cost-effective transit services are available to meet the mobility needs of the public. This is accomplished through a complex and dynamic process involving continuous measurement and estimation of ridership demand, followed by the development of convenient, cost-effective operating schedules to meet that demand. Service Planning reports and evaluates Metro ridership/route performance statistics.

4.0 SPECIAL SERVICES

Metro's Special Services unit is responsible for the overall direction of complementary paratransit service, as required by the Americans with Disabilities Act (ADA). It serves individuals who are unable to use Metro's regular, fully accessible fixed route bus and rail system. In addition, this unit is responsible for managing MetroLink and non-traditional transportation services, such as airport shuttles, college circulators, vanpools and, employer shuttles, provided by Metro either directly or through agreements with private providers and/or outside agencies and Metro's reduced fare program which allows services and people with disabilities to ride at a reduced rate.

5.0 TRANSPORTATION CENTERS

The Transportation Centers unit maintains the Metropolitan Transportation Center including NFTA corporate offices located at 181 Ellicott Street in Buffalo, the Transportation Centers in Niagara Falls, the Operations Control Center and Transit Police Headquarters. This department provides building maintenance and janitorial services in order to present a clean, comfortable and safe environment for

NFTA employees and the traveling public. This unit also monitors and performs services for the tenants of various facilities.

Also the responsibility of the Transportation Centers unit is Central Services. The Central Services department is responsible for implementing and maintaining administrative support services for all Authority departments, to include records management, operation of a centralized mail unit, document reproduction and document storage. The department coordinates purchases of office equipment to maximize resources and benefits, and is participating in the development of a long-range plan to address the Authority's telecommunication requirements.

6.0 CUSTOMER CARE

The Customer Care department is responsible for providing the public with quality bus and rail information. This is achieved through the operation of a customized automated telephone information system (IVR) along with an automated trip planner (ATIS) that is accessible to the public via the NFTA website. The Customer Care department processes nearly 4 million calls annually. Currently, the automated trip planner is utilized to plan more than 55,000 trips per month. Along with being responsible for resolving customer complaints and providing trip information, the department also administers the Emergency Ride Program. The Customer Care department ensures the distribution of 6 million bus and rail schedules annually to over 300 locations in Erie and Niagara Counties in addition to distributing another 3,000 schedules to individual customers.

**KEY PERFORMANCE INDICATORS
(Metro Fixed Route)**

	FYE10 <u>Actual</u>	FYE 11 Original <u>Budget</u>	FYE 11 Current <u>Estimate</u>	FYE 12 <u>Budget</u>
<u>Financial</u>				
Total Passengers	24.5m	27.0m	27.0m	27.3m
Passenger Fares	\$30.7m	\$29.5m	\$30.9m	\$30.9m
Total Revenue	\$31.5m	\$30.5m	\$31.6m	\$31.6m
<u>Customer Service</u>				
Complaints Received per 100,000 Boardings	3.2	2.6	2.7	2.6
Commendations per 100,000 Boardings	0.73	0.60	0.60	0.60
<u>Safety</u>				
Recordable Injury Rate	9.7	9.8	9.8	9.0
Cases with Days Away Rate	6.7	5.2	6.8	5.2
Days Away Rate	429.2	240	314.6	330.0
<u>Productivity</u>				
Unscheduled Absenteeism Rate	8.8%	8.0%	8.2%	8.0%
Miles between Service Interruptions	4,162	4,500	4,563	4,600
On-Time Performance	81.6%	80.2%	82.1%	82.0%

KEY POINTS

- Negotiate a UB Rail Pass Program.
- Implement enhanced partnership with UB (2020 Plan) and Buffalo Niagara Medical Campus.
- Receive delivery of mid-life rebuild rail cars
- Enhance customer amenities with Real Time Information Next Bus Interactive Voice Response, Bus Shelters and more Park & Rides.
- Negotiate Paratransit Medicare Service opportunities
- Continue to improve productivity and cost effectiveness of Metro services
- Continue marketing the LaSalle Park & Ride

PROGRAM AND SERVICE OBJECTIVES

- Conduct a Fare Collection Study.
- Maintain on-time performance and reduce service interruption.
- Reduce number of recordable accidents and cases with days away.
- Reduce rate of unscheduled employee absences.
- Continue to maximize efficiency of paratransit service.

NIAGARA FRONTIER TRANSPORTATION AUTHORITY
(ACCOUNTCO, ACCOUNTUNIT, ACCOUNT)
BUDGET WORKSHEETS - Fiscal Year 2011-12

Company 1 Niagara Frontier Transportation Authority
Division 40 METRO TRANS. AND MAINTENANCE
Department 0049 NFT METRO

Account	Description	2009-10 Actual	2010-11 Budget	2010-11 Sept. YTD Actual	2011-12 Req Budget	VARIANCE From Budget
510	EMPLOYEE SALARIES	5,168,147	5,219,138	3,977,514	4,943,838	275,300-
515	EMPLOYEE BENEFITS	2,029,449	2,391,637	1,814,717	2,372,343	19,294-
571	CONSULTANTS/OUTSIDE SERVICES			13,271		
591	PROJECTS	11,378-		44,827-	11,500-	11,500-
592	DIVISION OPERATIONS	7,186,223-	7,610,777-	5,756,170-	7,304,681-	306,096
TOTAL EXPENSES		5-	2-	4,505		2

40 METRO TRANS. AND MAINTENANCE
49 NFT METRO

EMPLOYEE GROUP: PB-ALL

Job Description	Grade/Step	Base Salary	Increase Amount	Longevity Amount	Scheduled Amount
Acting, Director Surfa	18	118,645		1,800	120,445
Sr. Operations Manager	20	92,710		1,500	94,210
Manager, Rail	20	88,390		1,500	89,890
MGR, BUS MAINTENANCE	20 0	88,000		900	88,900
SUPERINTENDENT, BUS SH	17 0	83,993		1,800	85,793
MANAGER, OPERATIONS	18	80,694		1,100	81,794
SUPT. TRANSPORTATION S	15	79,551		1,800	81,351
Mgr., Customer Service	15	77,934		700	78,634
MANAGER, OPERATIONS	18	75,324		1,500	76,824
Mgr. Planning Surface	19	74,000		1,100	75,100
MANAGER, RAIL MAINTENA	18 0	75,000			75,000
SUPT. RAIL VEHICLE MAI	16	71,298		1,500	72,798
SUPERINTENDENT, BUS GA	17	72,000			72,000
MANAGER, OPERATIONS	17	66,950		1,500	68,450
Manager, Finance & Adm	9	65,800		700	66,500
MARKETING MANAGER	18	66,000			66,000
TRAFFIC DATA ADMINISTR	15	64,232		1,500	65,732
SUPT. SERVICE PLANNING	15	63,045		1,100	64,145
ACTING, OPER MGR	18	61,346		1,500	62,846
SUPT., TRANSPORTATION	15	60,000			60,000
SENIOR SERVICE PLANNER	8	51,619		1,500	53,119
Administrative Analyst	9	53,044			53,044
SENIOR SERVICE PLANNER	8	52,508		500	53,008
ELIGIBILITY COORDINATO	8	52,000			52,000
TRANSPORTATION ASSISTA	8	50,611		1,100	51,711
Business Develop. Spec	9 0	48,232		900	49,132
SERVICE PLANNER/ANALYS	8	46,349			46,349
SR. ADMINISTRATIVE ASS	6	45,936			45,936
NON-REP Totals	28	1,925,211		25,500	1,950,711
Maint. Operations Coor	6 6	72,662		450	73,112
ASST. VEHICLE MAINTENA	6 6	68,502		1,750	70,252
VEHICLE MAINTENANCE SU	6 6	68,502		1,750	70,252
SUPV. , SYSTEMS/FACILI	6 6	68,502		1,750	70,252
SUPV. OPERATIONS & MAI	6 6	68,502		1,750	70,252
TRANSPORTATION SUPERVI		66,995	1,339	1,800	70,134
VEHICLE MAINTENANCE SU	6 6	68,502		1,350	69,852
EQUIPMENT ENGINEER	6 5	67,949	553	1,350	69,852
TRAIN CONTROL SUPERVIS	6 6	68,502		1,350	69,852
COMMUNICATIONS/FARE CO	6 6	68,502		450	68,952
COMMUNICATIONS/FARE CO	6 6	68,502			68,502
INVENTORY CONTROL MGR.	6 6	68,502			68,502
RELIEF SHOP SUPERVISOR	5 6	65,985		1,750	67,735
BODY SHOP SUPERVISOR	5 6	65,985		1,750	67,735
ASST RAIL CAR MAINTENA	5 6	65,985		1,750	67,735

40 METRO TRANS. AND MAINTENANCE
49 NFT METRO

EMPLOYEE GROUP: PB-ALL

Job Description	Grade/Step	Base Salary	Increase Amount	Longevity Amount	Scheduled Amount
ASST. VEHICLE MAINTENA	5 5	65,432	553	1,350	67,335
MACHINE SHOP SUPERVISO	5 6	65,985		1,350	67,335
ASST. VEHICLE MAINTENA	5 6	65,985		1,350	67,335
ASST RAIL CAR MAINTENA	5 4	61,658	3,774	1,350	66,782
ASST. SYSTEMS/FACILITI	5 6	65,985		450	66,435
VEHICLE MAINTENANCE SU	5 5	65,432	553		65,985
UNIT CHNG/BLDG MAINTEN	5 4	65,432	553		65,985
SUPV. BUILDING MAINT.	6 2	55,730	4,420		60,150
ELECTRIC POWER SUPERVI	6 2	55,730	4,420		60,150
COMMUNICATIONS/FARE CO	6 2	54,107	6,043		60,150
TECHNICAL TRAINER/QUAL	6 2	55,730	4,420		60,150
ASST. SUPV. ELECTRICAL	5 2	51,589	5,917	1,350	58,856
SUPERVISOR OF STORES -	5 3	54,736	2,517	1,350	58,603
ASST. SUPV. CAPITAL PR	5 2	53,137	4,369		57,506
PARATRANSIT DISPATCHER	1 5	54,350	1,087	1,800	57,237
PARATRANSIT DISPATCHER	1 5	54,350	1,087	1,500	56,937
TRANSPORTATION SUPERVI		53,609	1,072	1,500	56,181
PARATRANSIT DISPATCHER	1 5	54,350	1,087	700	56,137
PARATRANSIT DISPATCHER	1 5	54,350	1,087	700	56,137
ADA CONTROLLER	1 5	54,350	1,087	700	56,137
TRAINER	5 2	51,589	3,147		54,736
CUSTOMER SERVICE SUPER	4 2	49,690	3,035		52,725
TRANSPORTATION SUPERVI		49,582	992	500	51,074
TRANSPORTATION SUPERVI		49,582	992	500	51,074
TRANSPORTATION SUPERVI		49,582	992		50,574
TRANSPORTATION SUPERVI		46,275	925		47,200
UNION Totals	41	2,480,406	56,021	35,450	2,571,877
Department Totals	69	4,405,617	56,021	60,950	4,522,588

NIAGARA FRONTIER TRANSPORTATION AUTHORITY
(ACCOUNTCO, ACCOUNTUNIT, ACCOUNT)
BUDGET WORKSHEETS - Fiscal Year 2011-12

Company 2 NFT Metro System, Inc.
Division 40 METRO TRANS. AND MAINTENANCE
Department 0099 ADMINISTRATIVE AND GENERAL

Account	Description	2009-10 Actual	2010-11 Budget	2010-11 Sept. YTD Actual	2011-12 Req Budget	VARIANCE From Budget
584	FREIGHT	35,888	40,000	23,743	36,650	3,350-
	TOTAL EXPENSES	35,888	40,000	23,743	36,650	3,350-

NIAGARA FRONTIER TRANSPORTATION AUTHORITY
(ACCOUNTCO, ACCOUNTUNIT, ACCOUNT)
BUDGET WORKSHEETS - Fiscal Year 2011-12

Company 2 NFT Metro System, Inc.
Division 40 METRO TRANS. AND MAINTENANCE
Department 4099 METRO TRANS & MAINTENANCE

Account	Description	2009-10 Actual	2010-11 Budget	2010-11 Sept. YTD Actual	2011-12 Req Budget	VARIANCE From Budget
499	OTHER OPERATING REVENUES	19,723-	10,000-	35,654-	20,000-	10,000-
	TOTAL REVENUES	19,723-	10,000-	35,654-	20,000-	10,000-

NIAGARA FRONTIER TRANSPORTATION AUTHORITY
(ACCOUNTCO, ACCOUNTUNIT, ACCOUNT)
BUDGET WORKSHEETS - Fiscal Year 2011-12

Company 2 NFT Metro System, Inc.
Division 40 METRO TRANS. AND MAINTENANCE
Department 4099 METRO TRANS & MAINTENANCE

Account	Description	2009-10	2010-11	2010-11	2011-12	VARIANCE From Budget
		Actual	Budget	Sept. YTD Actual	Req Budget	
584	FREIGHT	3,199	2,500	1,212	3,000	500
	TOTAL EXPENSES	3,199	2,500	1,212	3,000	500

NIAGARA FRONTIER TRANSPORTATION AUTHORITY
(ACCOUNTCO, ACCOUNTUNIT, ACCOUNT)
BUDGET WORKSHEETS - Fiscal Year 2011-12

Company 2 NFT Metro System, Inc.
Division 40 METRO TRANS. AND MAINTENANCE
Department 4002 BUS REVENUES/EXPENSES

Account	Description	2009-10 Actual	2010-11 Budget	2010-11 Sept. YTD Actual	2011-12 Req Budget	VARIANCE From Budget
411	PASSENGER FARES	25,610,636-	25,237,662-	19,038,180-	26,556,528-	1,318,866-
494	ADVERTISING REVENUES	677,950-	779,161-	443,283-	556,050-	223,111
499	OTHER OPERATING REVENUES	4,294-	6,499-	2,819-	4,743-	1,756
	TOTAL REVENUES	26,292,880-	26,023,322-	19,484,282-	27,117,321-	1,093,999-

NIAGARA FRONTIER TRANSPORTATION AUTHORITY
(ACCOUNTCO, ACCOUNTUNIT, ACCOUNT)
BUDGET WORKSHEETS - Fiscal Year 2011-12

Company 2 NFT Metro System, Inc.
Division 40 METRO TRANS. AND MAINTENANCE
Department 4002 BUS REVENUES/EXPENSES

Account	Description	2009-10 Actual	2010-11 Budget	2010-11 Sept. YTD Actual	2011-12 Req Budget	VARIANCE From Budget
** NON-OPERATING/OPERATING ASSISTANCE **						
709	LOCAL OPERATING ASSISTANCE	21,336,449-	21,443,950-	15,992,097-	21,926,465-	482,515-
711	NY STATE OPERATING ASSISTANCE	32,781,010-	32,385,602-	24,333,070-	32,385,602-	
713	FEDERAL OPERATING ASSISTANCE	10,147,599-	10,354,633-	7,579,985-	10,354,633-	
	TOTAL OPERATING ASSISTANCE	64,265,058-	64,184,185-	47,905,152-	64,666,700-	482,515-

NIAGARA FRONTIER TRANSPORTATION AUTHORITY
(ACCOUNTCO, ACCOUNTUNIT, ACCOUNT)
BUDGET WORKSHEETS - Fiscal Year 2011-12

Company 2 NFT Metro System, Inc.
Division 40 METRO TRANS. AND MAINTENANCE
Department 4003 RAIL REVENUES/EXPENSES

Account	Description	2009-10 Actual	2010-11 Budget	2010-11 Sept. YTD Actual	2011-12 Req Budget	VARIANCE From Budget
411	PASSENGER FARES	4,496,912-	4,673,285-	3,743,154-	4,818,408-	145,123-
491	TRAFFIC FINES	68,407-	66,999-	64,395-	82,206-	15,207-
494	ADVERTISING REVENUES	55,417-	45,000-	39,991-	43,950-	1,050
499	OTHER OPERATING REVENUES	75,720-	46,499-	52,142-	75,500-	29,001-
TOTAL REVENUES		4,696,456-	4,831,783-	3,899,682-	5,020,064-	188,281-

NIAGARA FRONTIER TRANSPORTATION AUTHORITY
(ACCOUNTCO, ACCOUNTUNIT, ACCOUNT)
BUDGET WORKSHEETS - Fiscal Year 2011-12

Company 2 NFT Metro System, Inc.
Division 40 METRO TRANS. AND MAINTENANCE
Department 4003 RAIL REVENUES/EXPENSES

Account	Description	2009-10 Actual	2010-11 Budget	2010-11 Sept. YTD Actual	2011-12 Req Budget	VARIANCE From Budget
** NON-OPERATING/OPERATING ASSISTANCE **						
709	LOCAL OPERATING ASSISTANCE	11,424,651-	14,637,969-	8,850,924-	15,626,347-	988,378-
711	NY STATE OPERATING ASSISTANCE	10,216,130-	10,081,680-	7,561,260-	10,081,680-	
	TOTAL OPERATING ASSISTANCE	21,640,781-	24,719,649-	16,412,184-	25,708,027-	988,378-

NIAGARA FRONTIER TRANSPORTATION AUTHORITY
(ACCOUNTCO, ACCOUNTUNIT, ACCOUNT)
BUDGET WORKSHEETS - Fiscal Year 2011-12

Company 2 NFT Metro System, Inc.
Division 40 METRO TRANS. AND MAINTENANCE
Department 4004 PARATRANSIT REV/EXP

Account	Description	2009-10 Actual	2010-11 Budget	2010-11 Sept. YTD Actual	2011-12 Req Budget	VARIANCE From Budget
411	PASSENGER FARES	554,200-	411,210-	415,609-	630,569-	219,359-
	TOTAL REVENUES	554,200-	411,210-	415,609-	630,569-	219,359-

NIAGARA FRONTIER TRANSPORTATION AUTHORITY
(ACCOUNTCO, ACCOUNTUNIT, ACCOUNT)
BUDGET WORKSHEETS - Fiscal Year 2011-12

Company 2 NFT Metro System, Inc.
Division 40 METRO TRANS. AND MAINTENANCE
Department 4004 PARATRANSIT REV/EXP

Account	Description	2009-10 Actual	2010-11 Budget	2010-11 Sept. YTD Actual	2011-12 Req Budget	VARIANCE From Budget
** NON-OPERATING/OPERATING ASSISTANCE **						
709	LOCAL OPERATING ASSISTANCE	562,276-	564,555-	425,383-	583,300-	18,745-
711	NY STATE OPERATING ASSISTANCE	1,087,848-	1,076,667-	807,477-	1,076,667-	
713	FEDERAL OPERATING ASSISTANCE	1,700,000-	1,700,000-	1,275,000-	1,700,000-	
TOTAL OPERATING ASSISTANCE		3,350,124-	3,341,222-	2,507,860-	3,359,967-	18,745-

NIAGARA FRONTIER TRANSPORTATION AUTHORITY
(ACCOUNTCO, ACCOUNTUNIT, ACCOUNT)
BUDGET WORKSHEETS - Fiscal Year 2011-12

Company 2 NFT Metro System, Inc.
Division 40 METRO TRANS. AND MAINTENANCE
Department 4031 METRO MANAGER

Account	Description	2009-10 Actual	2010-11 Budget	2010-11 Sept. YTD Actual	2011-12 Req Budget	VARIANCE From Budget
511	MAINTENANCE SALARY & WAGES	120,362	117,296	83,569	1,828,746	1,711,450
512	TRANSPORTATION SALARY & WAGES	161,429	162,120	130,548	155,500	6,620-
514	GEN & ADMIN SALARY & WAGES	3,025	20,000	450,243	38,052	18,052
515	EMPLOYEE BENEFITS	154,456	205,998	132,480	1,423,698	1,217,700
541	INSURANCE	481,018	610,040	410,145	584,529	25,511-
571	CONSULTANTS/OUTSIDE SERVICES	425,287	456,515	354,932	381,714	74,801-
576	EMPLOYEE TRAVEL	4,583	5,000	2,182	4,375	625-
577	EMPLOYEE TRAINING		2,296			2,296-
580	GENERAL OFFICE	64,439	64,999	54,370	104,400	39,401
592	DIVISION OPERATIONS	123,577-	132,203-	102,023-	131,920-	283
TOTAL	EXPENSES	1,291,022	1,512,061	1,516,446	4,389,094	2,877,033

METRO TRANSPORTATION & MAINTENANCE (Attachment A)

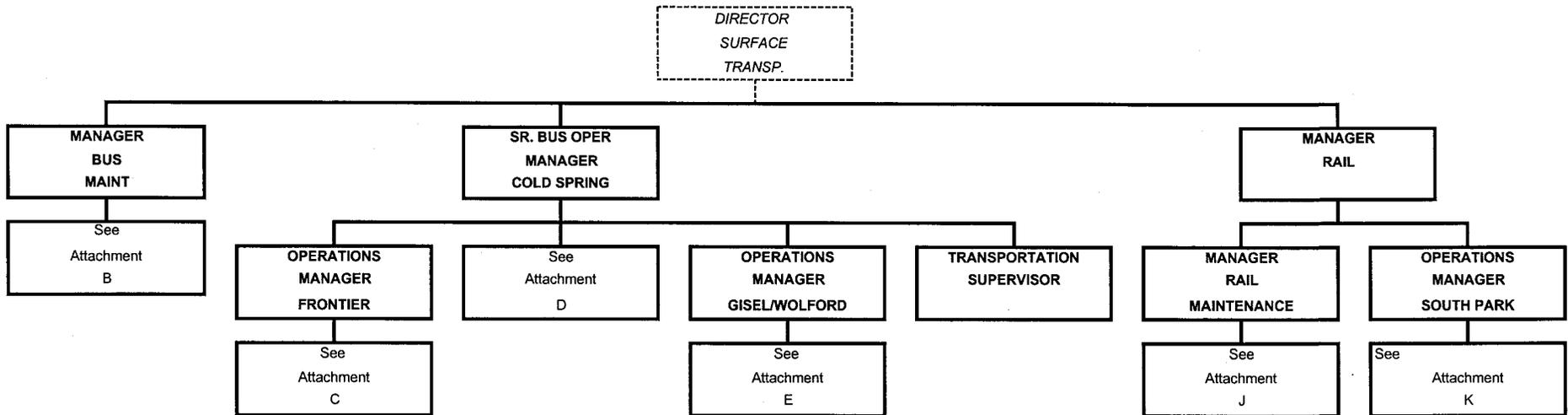

TOTAL EMPLOYEES:

NFTA

8

BUS MAINTENANCE (Attachment B)

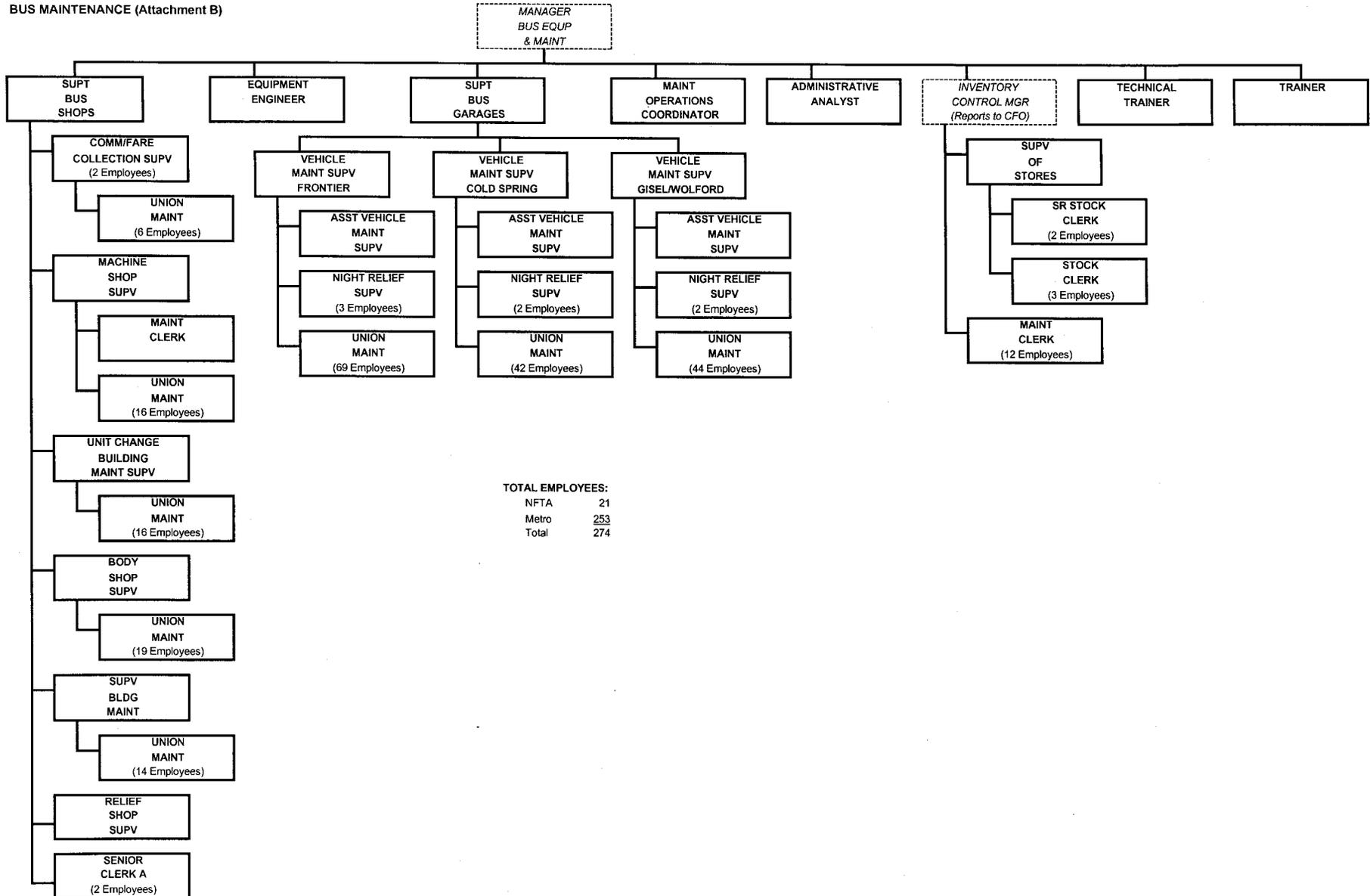

TOTAL EMPLOYEES:	
NFTA	21
Metro	253
Total	274

NIAGARA FRONTIER TRANSPORTATION AUTHORITY
(ACCOUNTCO, ACCOUNTUNIT, ACCOUNT)
BUDGET WORKSHEETS - Fiscal Year 2011-12

Company 2 NFT Metro System, Inc.
Division 40 METRO TRANS. AND MAINTENANCE
Department 4010 FRONTIER GARAGE

Account	Description	2009-10 Actual	2010-11 Budget	2010-11 Sept. YTD Actual	2011-12 Req Budget	VARIANCE From Budget
511	MAINTENANCE SALARY & WAGES	3,097,053	3,105,441	2,213,708	3,146,199	40,758
514	GEN & ADMIN SALARY & WAGES	2,456	3,000	1,200	3,000	
515	EMPLOYEE BENEFITS	2,125,641	2,138,608	1,591,915	2,217,036	78,428
521	REVENUE VEHICLE MAINT & TRANS	1,742,422	1,702,241	933,560	1,745,363	43,122
522	NON-REV VEHICLE MAINT & REPAIR	22,837	12,600	21,247	17,050	4,450
524	AUTOMOTIVE	2,898,528	2,303,537	1,810,826	3,308,274	1,004,737
525	FACILITIES	143,184	133,370	65,777	129,930	3,440-
527	ENVIRONMENTAL	39,417	40,200	34,242	38,000	2,200-
531	ELECTRIC POWER	202,776	211,914	166,184	233,381	21,467
532	GAS	265,680	268,964	65,266	278,964	10,000
533	WATER	18,534	19,461	15,697	30,000	10,539
553	POLICE PROTECTION		29,696		39,299	9,603
571	CONSULTANTS/OUTSIDE SERVICES	215,343	239,946	167,856	232,211	7,735-
580	GENERAL OFFICE	11,830	14,299	10,481	13,073	1,226-
TOTAL	EXPENSES	10,785,701	10,223,277	7,097,959	11,431,780	1,208,503

40 METRO TRANS. AND MAINTENANCE
4010 FRONTIER GARAGE

EMPLOYEE GROUP: PB-ALL

Job Description	Grade/Step	Base Salary	Increase Amount	Longevity Amount	Scheduled Amount
NIGHT GARAGE SUPERVISO		59,862	1,197	900	61,959
NIGHT GARAGE SUPERVISO		59,862	1,197	700	61,759
NIGHT GARAGE SUPERVISO		54,443	6,616		61,059
LEADER		48,713		1,200	49,913
LEADER		48,713		1,200	49,913
SPECIALIST		47,840		1,500	49,340
SPECIALIST		47,840		1,500	49,340
SPECIALIST		47,840		1,500	49,340
LEADER		48,713		500	49,213
MECHANIC A		46,820		1,500	48,320
MECHANIC A		46,820		1,500	48,320
MECHANIC A		46,820		1,500	48,320
MECHANIC A		46,820		1,500	48,320
MECHANIC A		46,820		1,500	48,320
SPECIALIST		47,840		300	48,140
MECHANIC A		46,820		1,200	48,020
MECHANIC A		46,820		1,200	48,020
MECHANIC A		46,820		1,200	48,020
MECHANIC A		46,820		1,200	48,020
MECHANIC A		46,820		1,200	48,020
MECHANIC A		46,820		1,200	48,020
MECHANIC A		46,820		1,200	48,020
SPECIALIST		47,840			47,840
MECHANIC A		46,820		900	47,720
MECHANIC A		46,820		900	47,720
MECHANIC A		46,820		900	47,720
MECHANIC A		46,820		700	47,520
MECHANIC A		46,820		700	47,520
MECHANIC A		46,820		500	47,320
MECHANIC A		46,820		500	47,320
MECHANIC A		46,820		300	47,120
MECHANIC A		46,820		300	47,120
MECHANIC A		46,820		300	47,120
MECHANIC A		46,820		300	47,120
MECHANIC A		46,820		300	47,120
MECHANIC A		46,820			46,820
MECHANIC A		46,820			46,820
MECHANIC A		46,820			46,820
MECHANIC A		46,820			46,820
MECHANIC B		44,907		900	45,807
BOOKER		44,907		700	45,607
HELPER WITH TOOLS		43,804		1,500	45,304
BOOKER		44,907		300	45,207
HELPER WITH TOOLS		43,804		1,200	45,004
HELPER		43,492		1,500	44,992
BOOKER		38,168	6,738		44,906

40 METRO TRANS. AND MAINTENANCE
4010 FRONTIER GARAGE

EMPLOYEE GROUP: PB-ALL

Job Description	Grade/Step	Base Salary	Increase Amount	Longevity Amount	Scheduled Amount
BOOKER		37,232	7,674		44,906
MECHANIC C		44,012		500	44,512
BOOKER		44,012		300	44,312
HELPER WITH TOOLS		43,804		500	44,304
HELPER		41,059		1,200	42,259
MECHANIC A		42,140			42,140
SPECIALIST		42,140			42,140
MECHANIC A		42,140			42,140
MECHANIC A		39,811	2,329		42,140
MECHANIC A		39,811	2,329		42,140
HELPER		37,128		900	38,028
HELPER		37,128		500	37,628
HELPER		37,128		500	37,628
MECHANIC A		33,675	3,784		37,459
HELPER		37,128		300	37,428
HELPER		37,128		300	37,428
HELPER WITH TOOLS		32,864	4,368		37,232
HELPER		31,553	5,575		37,128
MECHANIC B		30,804	2,871		33,675
HELPER		27,851	3,702		31,553
HELPER WITH TOOLS		26,291	2,181		28,472
HELPER		22,276	1,851		24,127
HELPER		22,276	1,851		24,127
HELPER		22,276	1,851		24,127
HELPER		22,276	1,851		24,127
HELPER		22,276	1,851		24,127
UNION Totals	72	3,070,674	59,816	42,900	3,173,390
Department Totals	72	3,070,674	59,816	42,900	3,173,390

NIAGARA FRONTIER TRANSPORTATION AUTHORITY
(ACCOUNTCO, ACCOUNTUNIT, ACCOUNT)
BUDGET WORKSHEETS - Fiscal Year 2011-12

Company 2 NFT Metro System, Inc.
Division 40 METRO TRANS. AND MAINTENANCE
Department 4011 COLD SPRINGS GARAGE

Account	Description	2009-10 Actual	2010-11 Budget	2010-11 Sept. YTD Actual	2011-12 Req Budget	VARIANCE From Budget
511	MAINTENANCE SALARY & WAGES	1,963,308	2,105,215	1,485,907	1,800,966	304,249-
514	GEN & ADMIN SALARY & WAGES	8,079		3,469	4,939	4,939
515	EMPLOYEE BENEFITS	1,330,869	1,448,388	1,060,903	1,271,357	177,030-
521	REVENUE VEHICLE MAINT & TRANS	1,223,191	1,109,642	1,166,545	1,210,716	101,074
522	NON-REV VEHICLE MAINT & REPAIR	17,311	15,000	4,315	15,000	
524	AUTOMOTIVE	1,489,350	1,210,583	980,518	1,740,603	530,020
525	FACILITIES	43,819	56,791	24,254	55,656	1,135-
527	ENVIRONMENTAL	37,139	28,000	19,958	29,000	1,000
533	WATER	349	366	273	365	1-
553	POLICE PROTECTION	35,089	69,000	26,700	47,000	22,000-
571	CONSULTANTS/OUTSIDE SERVICES	230,456	242,029	180,295	232,889	9,140-
580	GENERAL OFFICE	2,791	8,500	2,122	8,000	500-
591	PROJECTS	16,005-				
	TOTAL EXPENSES	6,365,746	6,293,514	4,955,259	6,416,491	122,978

40 METRO TRANS. AND MAINTENANCE
4011 COLD SPRINGS GARAGE

EMPLOYEE GROUP: PB-ALL

Job Description	Grade/Step	Base Salary	Increase Amount	Longevity Amount	Scheduled Amount
NIGHT GARAGE SUPERVISO		59,862	1,197	500	61,559
NIGHT GARAGE SUPERVISO		50,876	4,656	1,800	57,332
LEADER		48,713		1,500	50,213
LEADER		48,713		1,200	49,913
SPECIALIST		47,840		1,500	49,340
SPECIALIST		47,840		700	48,540
MECHANIC A		46,820		1,500	48,320
MECHANIC A		46,820		1,500	48,320
SPECIALIST		47,840		300	48,140
MECHANIC A		46,820		1,200	48,020
MECHANIC A		46,820		1,200	48,020
MECHANIC A		46,820		700	47,520
MECHANIC A		46,820		500	47,320
MECHANIC A		46,820			46,820
MECHANIC A		46,820			46,820
BOOKER		44,907		1,200	46,107
BOOKER		44,907		1,200	46,107
BOOKER		44,907		900	45,807
MECHANIC B		44,907		900	45,807
MECHANIC C		44,012		900	44,912
MECHANIC B		44,012		300	44,312
HELPER WITH TOOLS		43,804		500	44,304
HELPER WITH TOOLS		43,804		300	44,104
HELPER WITH TOOLS		43,804		300	44,104
SPECIALIST		43,056			43,056
MECHANIC A		42,140			42,140
MECHANIC A		42,140			42,140
MECHANIC A		42,140			42,140
HELPER		37,128		900	38,028
MECHANIC A		33,675	3,784		37,459
MECHANIC A		33,009	4,450		37,459
MECHANIC A		33,009	4,450		37,459
MECHANIC A		33,009	4,450		37,459
MECHANIC A		33,009	4,450		37,459
HELPER		37,128		300	37,428
HELPER		37,128		300	37,428
HELPER		37,128		300	37,428
HELPER		27,851	3,702		31,553
HELPER		26,000	1,851		27,851
HELPER		26,000	1,851		27,851
HELPER		24,128	1,872		26,000
HELPER		24,128	1,872		26,000
HELPER		22,276	1,851		24,127

40 METRO TRANS. AND MAINTENANCE
4011 COLD SPRINGS GARAGE

EMPLOYEE GROUP: PB-ALL

Job Description	Grade/Step	Base Salary	Increase Amount	Longevity Amount	Scheduled Amount
UNION Totals	44	1,806,210	40,436	23,600	1,870,246
Department Totals	44	1,806,210	40,436	23,600	1,870,246

NIAGARA FRONTIER TRANSPORTATION AUTHORITY
(ACCOUNTCO, ACCOUNTUNIT, ACCOUNT)
BUDGET WORKSHEETS - Fiscal Year 2011-12

Company 2 NFT Metro System, Inc.
Division 40 METRO TRANS. AND MAINTENANCE
Department 4013 BABCOCK GARAGE

Account	Description	2009-10 Actual	2010-11 Budget	2010-11 Sept. YTD Actual	2011-12 Req Budget	VARIANCE From Budget
511	MAINTENANCE SALARY & WAGES	2,011,692	2,122,297	1,457,922	1,831,606	290,691-
514	GEN & ADMIN SALARY & WAGES	10,460	5,000	6,685	6,750	1,750
515	EMPLOYEE BENEFITS	1,384,925	1,463,580	1,042,443	1,294,202	169,377-
521	REVENUE VEHICLE MAINT & TRANS	1,109,933	1,038,100	881,609	1,130,451	92,351
522	NON-REV VEHICLE MAINT & REPAIR	11,067	10,000	7,047	10,000	
524	AUTOMOTIVE	1,777,689	1,365,970	1,133,896	2,057,901	691,931
525	FACILITIES	112,096	52,641	54,370	78,273	25,632
527	ENVIRONMENTAL	47,202	28,000	12,783	47,000	19,000
531	ELECTRIC POWER	94,704	99,439	81,920	114,930	15,491
532	GAS	131,980	138,579	32,617	138,579	
533	WATER	12,699	13,334	11,420	16,732	3,398
553	POLICE PROTECTION	34,971	69,000	26,700	32,700	36,300-
571	CONSULTANTS/OUTSIDE SERVICES	216,905	238,750	178,206	230,603	8,147-
580	GENERAL OFFICE	3,603	4,099	1,994	4,159	60
TOTAL	EXPENSES	6,959,926	6,648,789	4,929,612	6,993,886	345,098

40 METRO TRANS. AND MAINTENANCE
4013 BABCOCK GARAGE

EMPLOYEE GROUP: PB-ALL

Job Description	Grade/Step	Base Salary	Increase Amount	Longevity Amount	Scheduled Amount
NIGHT GARAGE SUPERVISO	4 1	59,862	1,197	1,800	62,859
NIGHT GARAGE SUPERVISO	2	50,876	4,656		55,532
SPECIALIST		47,840		1,500	49,340
SPECIALIST		47,840		1,500	49,340
LEADER		48,713		500	49,213
LEADER		48,713		500	49,213
SPECIALIST		47,840		1,200	49,040
SPECIALIST		47,840		1,200	49,040
MECHANIC A		46,820		1,500	48,320
MECHANIC A		46,820		1,500	48,320
MECHANIC A		46,820		1,500	48,320
MECHANIC A		46,820		1,500	48,320
MECHANIC A		46,820		1,200	48,020
SPECIALIST		47,840			47,840
MECHANIC A		46,820		700	47,520
MECHANIC A		46,820		300	47,120
MECHANIC A		46,820		300	47,120
MECHANIC A		46,820		300	47,120
MECHANIC A		46,820		300	47,120
BOOKER		44,907		1,500	46,407
MECHANIC B		44,907		900	45,807
BOOKER		44,907		900	45,807
BOOKER		44,907		500	45,407
MECHANIC B		44,907		500	45,407
MECHANIC C		44,012		300	44,312
HELPER WITH TOOLS		43,804		500	44,304
HELPER WITH TOOLS		43,804		300	44,104
HELPER WITH TOOLS		37,232	6,572		43,804
MECHANIC A		39,811	2,329		42,140
MECHANIC A		39,811	2,329		42,140
MECHANIC A		39,811	2,329		42,140
MECHANIC A		39,811	2,329		42,140
MECHANIC A		37,460	2,350		39,810
MECHANIC A		35,921	3,889		39,810
MECHANIC A		35,921	3,889		39,810
HELPER		37,128		900	38,028
HELPER		37,128		900	38,028
HELPER		37,128		500	37,628
MECHANIC A		33,675	3,784		37,459
MECHANIC A		33,009	4,450		37,459
HELPER		37,128		300	37,428
HELPER		37,128		300	37,428
HELPER WITH TOOLS		32,864	4,368		37,232
HELPER		22,276	1,851		24,127
HELPER		22,276	1,851		24,127
HELPER		22,276	1,851		24,127

40 METRO TRANS. AND MAINTENANCE
4013 BABCOCK GARAGE

EMPLOYEE GROUP: PB-ALL

Job Description	Grade/Step	Base Salary	Increase Amount	Longevity Amount	Scheduled Amount
UNION Totals	46	1,929,513	50,024	25,600	2,005,137
Department Totals	46	1,929,513	50,024	25,600	2,005,137

NIAGARA FRONTIER TRANSPORTATION AUTHORITY
(ACCOUNTCO, ACCOUNTUNIT, ACCOUNT)
BUDGET WORKSHEETS - Fiscal Year 2011-12

Company 2 NFT Metro System, Inc.
Division 40 METRO TRANS. AND MAINTENANCE
Department 4014 SHOPS

Account	Description	2009-10 Actual	2010-11 Budget	2010-11 Sept. YTD Actual	2011-12 Req Budget	VARIANCE From Budget
511	MAINTENANCE SALARY & WAGES	3,319,188	3,378,516	2,478,270	3,322,320	56,196-
514	GEN & ADMIN SALARY & WAGES	65,859	47,072	41,078	48,273	1,201
515	EMPLOYEE BENEFITS	2,305,336	2,356,806	1,790,411	2,372,897	16,091
521	REVENUE VEHICLE MAINT & TRANS	387,775	509,000	290,326	385,750	123,250-
522	NON-REV VEHICLE MAINT & REPAIR	38,793	67,499	31,653	40,000	27,499-
523	IMPROVEMENTS & REPLACEMENTS	5,476	5,000	2,889	5,000	
524	AUTOMOTIVE	3,749	7,112	2,358	7,036	76-
525	FACILITIES	90,597	84,999	73,109	93,000	8,001
527	ENVIRONMENTAL	7,614	5,000	3,441	5,000	
531	ELECTRIC POWER	248,674	261,107	221,039	312,000	50,893
532	GAS	236,124	245,930	65,194	247,930	2,000
533	WATER	12,612	13,243	16,919	20,709	7,466
553	POLICE PROTECTION	180,931	199,560	42	160,000	39,560-
571	CONSULTANTS/OUTSIDE SERVICES	1,523,759	1,634,611	1,155,525	1,747,563	112,952
576	EMPLOYEE TRAVEL	3		7		
577	EMPLOYEE TRAINING	8,321	3,909	3,803	8,321	4,412
580	GENERAL OFFICE	20,732	27,499	13,089	22,000	5,499-
582	TRANSPORTATION EXPENSE	8,994	13,500	4,210	10,500	3,000-
591	PROJECTS	3,596-				
TOTAL	EXPENSES	8,460,941	8,860,363	6,193,363	8,808,299	52,064-

40 METRO TRANS. AND MAINTENANCE
4014 SHOPS

EMPLOYEE GROUP: PB-ALL

Job Description	Grade/Step	Base Salary	Increase Amount	Longevity Amount	Scheduled Amount
LEADER		48,713		1,500	50,213
LEADER		48,713		1,500	50,213
LEADER		48,713		1,500	50,213
LEADER		48,713		1,500	50,213
LEADER		48,713		1,200	49,913
LEADER		48,713		1,200	49,913
SPECIALIST		47,840		1,500	49,340
SPECIALIST		47,840		1,500	49,340
SPECIALIST		47,840		1,500	49,340
SPECIALIST		47,840		1,200	49,040
SPECIALIST		47,840		1,200	49,040
SPECIALIST		47,840		1,200	49,040
SPECIALIST		47,840		900	48,740
SPECIALIST		47,840		900	48,740
SPECIALIST		47,840		900	48,740
SPECIALIST		47,840		700	48,540
SPECIALIST		47,840		700	48,540
SPECIALIST		47,840		700	48,540
SPECIALIST		47,840		700	48,540
SPECIALIST		47,840		700	48,540
SPECIALIST		47,840		700	48,540
SPECIALIST		47,840		700	48,540
SPECIALIST		47,840		500	48,340
MECHANIC A		46,820		1,500	48,320
SPECIALIST		47,840		300	48,140
SPECIALIST		47,840		300	48,140
SPECIALIST		47,840		300	48,140
SPECIALIST		47,840		300	48,140
SPECIALIST		47,840		300	48,140
MECHANIC A		46,820		1,200	48,020
MECHANIC A		46,820		1,200	48,020
SPECIALIST		47,840			47,840
SPECIALIST		47,840			47,840
SPECIALIST		47,840			47,840
SPECIALIST		43,056	4,784		47,840
SPECIALIST		43,056	4,784		47,840
SPECIALIST		43,056	4,784		47,840
SPECIALIST		43,056	4,784		47,840
MECHANIC A		46,820		900	47,720
MECHANIC A		46,820		900	47,720
MECHANIC A		46,820		300	47,120
MECHANIC A		46,820		300	47,120
MECHANIC A		46,820		300	47,120
MECHANIC A		46,820		300	47,120
MECHANIC A		46,820		300	47,120
MECHANIC A		46,820			46,820
MECHANIC A		42,140	4,680		46,820
MECHANIC A		42,140	4,680		46,820

40 METRO TRANS. AND MAINTENANCE
4014 SHOPS

EMPLOYEE GROUP: PB-ALL

Job Description	Grade/Step	Base Salary	Increase Amount	Longevity Amount	Scheduled Amount
VAULT TRANSPORT DRIVER		45,073		1,500	46,573
MECHANIC B		44,907		1,200	46,107
MECHANIC B		44,907		1,200	46,107
MECHANIC B		44,907		500	45,407
MECHANIC B		44,907		300	45,207
MECHANIC C		44,012		500	44,512
HELPER WITH TOOLS		43,804		500	44,304
HELPER WITH TOOLS		43,804		500	44,304
SPECIALIST		43,056			43,056
SPECIALIST		40,664	2,392		43,056
SPECIALIST		40,664	2,392		43,056
MECHANIC A		39,811	2,329		42,140
MECHANIC A		37,460	2,350		39,810
MECHANIC A		37,460	2,350		39,810
MECHANIC A		37,460	2,350		39,810
MECHANIC A		35,048	4,762		39,810
MECHANIC A		35,921	3,889		39,810
MECHANIC A		37,460	2,350		39,810
SPECIALIST		35,921	3,889		39,810
SPECIALIST		35,921	3,889		39,810
SPECIALIST		32,864	5,408		38,272
MECHANIC A		33,009	4,450		37,459
MECHANIC A		33,009	4,450		37,459
HELPER		37,128		300	37,428
HELPER		31,553	5,575		37,128
UNION Totals	71	3,145,872	81,321	38,800	3,265,993
Department Totals	71	3,145,872	81,321	38,800	3,265,993

QB204 Date 03/23/11
Time 14:17

NIAGARA FRONTIER TRANSPORTATION AUTHORITY
(ACCOUNTCO, ACCOUNTUNIT, ACCOUNT)
BUDGET WORKSHEETS - Fiscal Year 2011-12

Page 126
CREDITS = (-)
DEBITS = (+)

Company 2 NFT Metro System, Inc.
Division 40 METRO TRANS. AND MAINTENANCE
Department 4015 BUS LOOPS

Account	Description	2009-10 Actual	2010-11 Budget	2010-11 Sept. YTD Actual	2011-12 Req Budget	VARIANCE From Budget
525	FACILITIES	35,265	29,999	18,608	29,999	
531	ELECTRIC POWER	88,801	93,241	63,616	90,960	2,281-
533	WATER	8,724	9,159	3,155	9,435	276
TOTAL	EXPENSES	132,790	132,399	85,379	130,394	2,005-

NIAGARA FRONTIER TRANSPORTATION AUTHORITY
(ACCOUNTCO, ACCOUNTUNIT, ACCOUNT)
BUDGET WORKSHEETS - Fiscal Year 2011-12

Company 2 NFT Metro System, Inc.
Division 40 METRO TRANS. AND MAINTENANCE
Department 4016 MECHANICAL

Account	Description	2009-10 Actual	2010-11 Budget	2010-11 Sept. YTD Actual	2011-12 Req Budget	VARIANCE From Budget
511	MAINTENANCE SALARY & WAGES	132,273	137,554	103,897	135,259	2,295-
515	EMPLOYEE BENEFITS	90,507	94,637	73,095	95,222	585
571	CONSULTANTS/OUTSIDE SERVICES	1,612				
580	GENERAL OFFICE	9,032	8,239	4,938	8,000	239-
TOTAL EXPENSES		233,424	240,430	181,930	238,481	1,949-

40 METRO TRANS. AND MAINTENANCE
4016 MECHANICAL

EMPLOYEE GROUP: PB-ALL

Job Description	Grade/Step	Base Salary	Increase Amount	Longevity Amount	Scheduled Amount
SENIOR CLERK A		43,846		900	44,746
SENIOR CLERK A		43,846		500	44,346
MAINTENANCE CLERK		42,972		1,200	44,172
UNION Totals	3	130,664		2,600	133,264
Department Totals	3	130,664		2,600	133,264

NIAGARA FRONTIER TRANSPORTATION AUTHORITY
(ACCOUNTCO, ACCOUNTUNIT, ACCOUNT)
BUDGET WORKSHEETS - Fiscal Year 2011-12

Company 2 NFT Metro System, Inc.
Division 40 METRO TRANS. AND MAINTENANCE
Department 4019 STOREROOM- BUS

Account	Description	2009-10 Actual	2010-11 Budget	2010-11 Sept. YTD Actual	2011-12 Req Budget	VARIANCE From Budget
511	MAINTENANCE SALARY & WAGES				524,264	524,264
514	GEN & ADMIN SALARY & WAGES	211,645	219,539	166,354	282,208	62,669
515	EMPLOYEE BENEFITS	144,031	151,042	116,964	567,756	416,714
523	IMPROVEMENTS & REPLACEMENTS	938	4,000	6,160	7,000	3,000
534	TELEPHONE	1,212	1,273	935	1,269	4-
571	CONSULTANTS/OUTSIDE SERVICES	113,056	116,151	142,180	99,195	16,956-
577	EMPLOYEE TRAINING					
580	GENERAL OFFICE	3,438	2,249	1,608	3,250	1,001
TOTAL	EXPENSES	474,320	494,254	434,201	1,484,942	990,688

40 METRO TRANS. AND MAINTENANCE
4019 STOREROOM- BUS

EMPLOYEE GROUP: PB-ALL

Job Description	Grade/Step	Base Salary	Increase Amount	Longevity Amount	Scheduled Amount
SENIOR STOCK CLERK		45,011		1,500	46,511
SENIOR STOCK CLERK		45,011		500	45,511
STOCK CLERK		44,262		1,200	45,462
STOCK CLERK		44,262		900	45,162
STOCK CLERK		44,262		900	45,162
MAINTENANCE CLERK		42,972		1,500	44,472
MAINTENANCE CLERK		42,972		1,500	44,472
MAINTENANCE CLERK		42,972		900	43,872
MAINTENANCE CLERK		42,972		900	43,872
MAINTENANCE CLERK		42,972		900	43,872
MAINTENANCE CLERK		42,972		900	43,872
MAINTENANCE CLERK		42,972		700	43,672
MAINTENANCE CLERK		42,972		500	43,472
MAINTENANCE CLERK		42,972		500	43,472
MAINTENANCE CLERK		42,972		300	43,272
MAINTENANCE CLERK		42,972			42,972
MAINTENANCE CLERK		42,972			42,972
UNION Totals	17	738,472		13,600	752,072
Department Totals	17	738,472		13,600	752,072

FRONTIER (Attachment C)

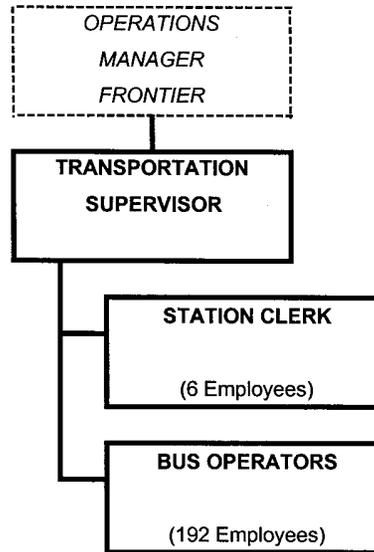

TOTAL EMPLOYEES:

NFTA	1
Metro	<u>198</u>
Total	199

NIAGARA FRONTIER TRANSPORTATION AUTHORITY
(ACCOUNTCO, ACCOUNTUNIT, ACCOUNT)
BUDGET WORKSHEETS - Fiscal Year 2011-12

Company 2 NFT Metro System, Inc.
Division 40 METRO TRANS. AND MAINTENANCE
Department 4020 FRONTIER STATION

Account	Description	2009-10 Actual	2010-11 Budget	2010-11 Sept. YTD Actual	2011-12 Req Budget	VARIANCE From Budget
512	TRANSPORTATION SALARY & WAGES	9,104,241	8,925,297	6,930,379	9,050,936	125,639
513	I&D SALARY & WAGES	2,822	4,000	2,126	3,200	800-
514	GEN & ADMIN SALARY & WAGES	44,983	61,000	31,258	59,780	1,220-
515	EMPLOYEE BENEFITS	6,208,810	6,184,864	4,932,817	6,416,196	231,332
571	CONSULTANTS/OUTSIDE SERVICES	289,156	302,844	259,789	268,357	34,487-
576	EMPLOYEE TRAVEL	760	749	152	735	14-
582	TRANSPORTATION EXPENSE	27,064	17,600	12,413	24,500	6,900
TOTAL EXPENSES		15,677,836	15,496,354	12,168,934	15,823,704	327,350

40 METRO TRANS. AND MAINTENANCE
4020 FRONTIER STATION

EMPLOYEE GROUP: PB-ALL

Job Description	Grade/Step	Base Salary	Increase Amount	Longevity Amount	Scheduled Amount
OPERATOR		33,349	2,566		35,915
OPERATOR		33,349	2,566		35,915
OPERATOR		33,349	2,566		35,915
OPERATOR		33,349	2,566		35,915
OPERATOR		33,349	2,566		35,915
OPERATOR		33,349	2,566		35,915
OPERATOR		33,349	2,566		35,915
OPERATOR	33	30,784	2,565		33,349
UNION Totals	192	9,172,058	202,656	111,100	9,485,814
Department Totals	192	9,172,058	202,656	111,100	9,485,814

COLD SPRING (Attachment D)

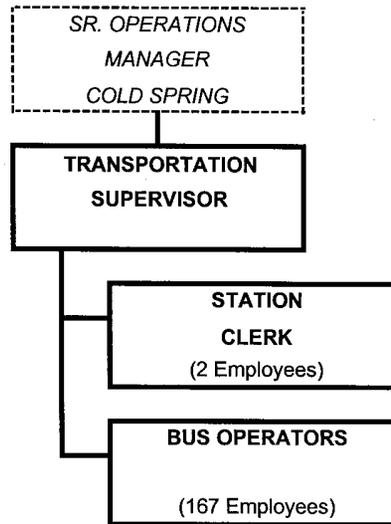

TOTAL EMPLOYEES:

NFTA	1
Metro	<u>169</u>
Total	170

NIAGARA FRONTIER TRANSPORTATION AUTHORITY
(ACCOUNTCO, ACCOUNTUNIT, ACCOUNT)
BUDGET WORKSHEETS - Fiscal Year 2011-12

Company 2 NFT Metro System, Inc.
Division 40 METRO TRANS. AND MAINTENANCE
Department 4021 COLD SPRINGS STATION

Account	Description	2009-10 Actual	2010-11 Budget	2010-11 Sept. YTD Actual	2011-12 Req Budget	VARIANCE From Budget
512	TRANSPORTATION SALARY & WAGES	7,467,887	7,624,912	5,606,920	7,344,973	279,939-
513	I&D SALARY & WAGES	2,233	3,200	2,066	2,750	450-
514	GEN & ADMIN SALARY & WAGES	35,086	51,252	34,976	27,800	23,452-
515	EMPLOYEE BENEFITS	5,088,173	5,283,404	3,997,600	5,192,368	91,035-
571	CONSULTANTS/OUTSIDE SERVICES	263,501	266,249	198,412	261,805	4,444-
576	EMPLOYEE TRAVEL	316	600	175	588	12-
577	EMPLOYEE TRAINING		99			99-
582	TRANSPORTATION EXPENSE	23,489	13,200	7,721	20,650	7,450
TOTAL	EXPENSES	12,880,685	13,242,916	9,847,870	12,850,934	391,981-

40 METRO TRANS. AND MAINTENANCE
4021 COLD SPRINGS STATION

EMPLOYEE GROUP: PB-ALL

Job Description	Grade/Step	Base Salary	Increase Amount	Longevity Amount	Scheduled Amount
STATION CLERK		45,073		1,200	46,273
OPERATOR		37,554	5,007		42,561
OPERATOR		37,554	5,007		42,561
OPERATOR		37,554	5,007		42,561
OPERATOR		37,554	5,007		42,561
OPERATOR		37,554	5,007		42,561
OPERATOR		37,554	5,007		42,561
OPERATOR		37,554	5,007		42,561
OPERATOR		37,554	5,007		42,561
OPERATOR		37,554	5,007		42,561
OPERATOR		37,554	5,007		42,561
OPERATOR		37,554	5,007		42,561
OPERATOR		35,050	2,504		37,554
OPERATOR		35,050	2,504		37,554
OPERATOR		35,050	2,504		37,554
OPERATOR		35,050	2,504		37,554
OPERATOR		32,546	2,504		35,050
OPERATOR		32,546	2,504		35,050
OPERATOR		32,546	2,504		35,050
OPERATOR		32,546	2,504		35,050
OPERATOR		32,546	2,504		35,050
OPERATOR		32,546	2,504		35,050
OPERATOR		32,546	2,504		35,050
OPERATOR		32,546	2,504		35,050
OPERATOR		32,546	2,504		35,050
OPERATOR		30,043	2,503		32,546
UNION Totals	164	7,723,610	185,272	81,700	7,990,582
Department Totals	164	7,723,610	185,272	81,700	7,990,582

GISEL/WOLFORD (Attachment E)

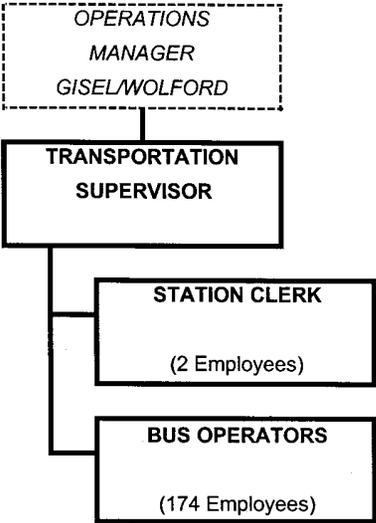

TOTAL EMPLOYEES:

NFTA	1
Metro	176
Total	<u>177</u>

NIAGARA FRONTIER TRANSPORTATION AUTHORITY
(ACCOUNTCO, ACCOUNTUNIT, ACCOUNT)
BUDGET WORKSHEETS - Fiscal Year 2011-12

Company 2 NFT Metro System, Inc.
Division 40 METRO TRANS. AND MAINTENANCE
Department 4023 BABCOCK STATION

Account	Description	2009-10 Actual	2010-11 Budget	2010-11 Sept. YTD Actual	2011-12 Req Budget	VARIANCE From Budget
512	TRANSPORTATION SALARY & WAGES	7,529,080	7,491,065	5,686,731	7,446,013	45,052-
513	I&D SALARY & WAGES	3,767	4,100	1,974	3,600	500-
514	GEN & ADMIN SALARY & WAGES	25,927	32,960	21,322	27,750	5,210-
515	EMPLOYEE BENEFITS	5,107,503	5,179,350	4,040,143	5,264,063	84,713
571	CONSULTANTS/OUTSIDE SERVICES	195,375	203,351	116,475	202,290	1,061-
576	EMPLOYEE TRAVEL		600			600-
577	EMPLOYEE TRAINING		99			99-
582	TRANSPORTATION EXPENSE	17,823	15,700	8,616	17,250	1,550
TOTAL	EXPENSES	12,879,475	12,927,225	9,875,261	12,960,966	33,741

BUS & RAIL TRANSPORTATION (Attachment F)

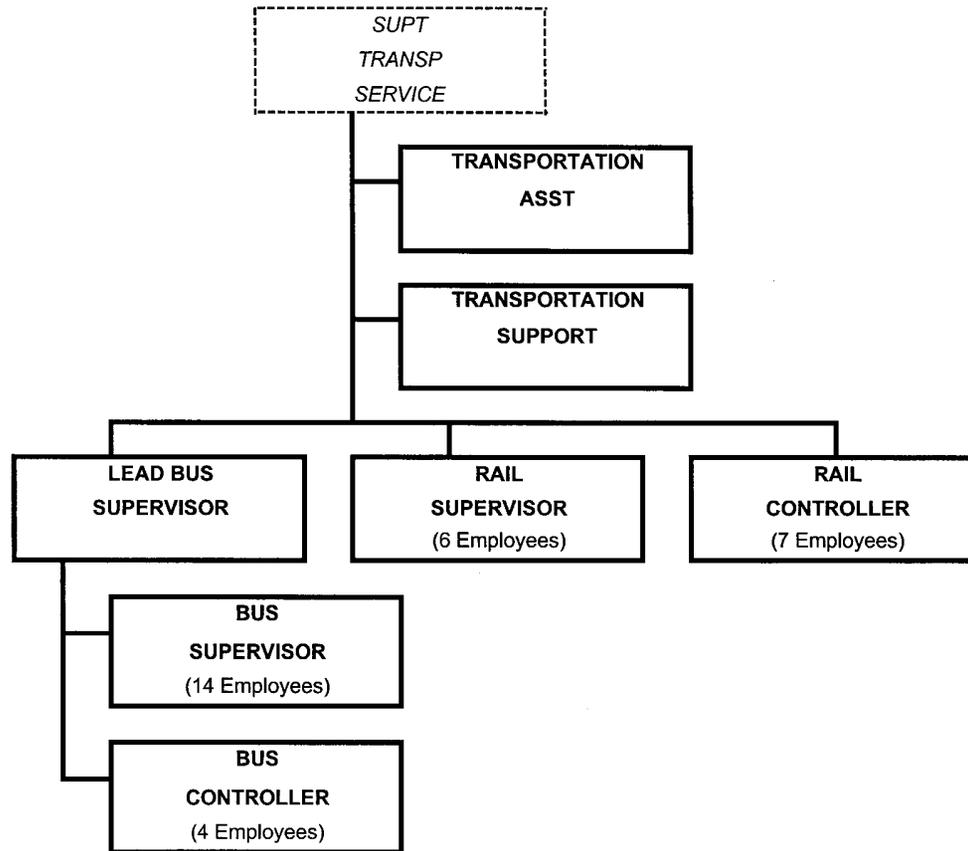

TOTAL EMPLOYEES:

NFTA	1
Metro	<u>33</u>
Total	34

NIAGARA FRONTIER TRANSPORTATION AUTHORITY
(ACCOUNTCO, ACCOUNTUNIT, ACCOUNT)
BUDGET WORKSHEETS - Fiscal Year 2011-12

Company 2 NFT Metro System, Inc.
Division 40 METRO TRANS. AND MAINTENANCE
Department 4027 BUS TRANSPORTATION

Account	Description	2009-10 Actual	2010-11 Budget	2010-11 Sept. YTD Actual	2011-12 Req Budget	VARIANCE From Budget
512	TRANSPORTATION SALARY & WAGES	1,370,694	1,356,727	1,028,097	1,402,458	45,731
515	EMPLOYEE BENEFITS	916,099	933,429	730,288	987,330	53,901
571	CONSULTANTS/OUTSIDE SERVICES	259,996	279,085	215,873	202,103	76,982-
576	EMPLOYEE TRAVEL	112				
577	EMPLOYEE TRAINING	396	7,097		396	6,701-
580	GENERAL OFFICE	34,342	25,000	35,345	34,500	9,500
582	TRANSPORTATION EXPENSE	139,006	129,999	123,746	175,000	45,001
TOTAL	EXPENSES	2,720,645	2,731,337	2,133,349	2,801,787	70,450

40 METRO TRANS. AND MAINTENANCE
4027 BUS TRANSPORTATION

EMPLOYEE GROUP: PB-ALL

Job Description	Grade/Step	Base Salary	Increase Amount	Longevity Amount	Scheduled Amount
BUS SUPERVISOR	2 5	69,752	1,395	1,800	72,947
BUS SUPERVISOR	2 5	67,011	1,340	1,800	70,151
BUS SUPERVISOR	2 5	67,011	1,340	1,800	70,151
BUS SUPERVISOR	2 5	67,011	1,340	1,800	70,151
BUS CONTROLLER	1 5	60,257	1,205	1,800	63,262
BUS CONTROLLER	1 5	60,257	1,205	1,800	63,262
BUS CONTROLLER	1 5	56,487	4,975	1,500	62,962
BUS CONTROLLER	1 5	60,257	1,205	1,500	62,962
BUS SUPERVISOR	2 5	56,430	1,129	1,800	59,359
BUS SUPERVISOR	2 5	56,430	1,129	1,500	59,059
BUS SUPERVISOR	2 5	56,430	1,129	1,500	59,059
BUS SUPERVISOR	2 5	56,430	1,129	1,500	59,059
BUS SUPERVISOR	2 5	56,430	1,129	1,500	59,059
BUS SUPERVISOR	2 5	56,430	1,129	1,100	58,659
BUS SUPERVISOR	2 5	50,772	6,787	1,100	58,659
BUS SUPERVISOR	2 5	56,430	1,129	1,100	58,659
BUS SUPERVISOR	2 5	56,430	1,129	1,100	58,659
BUS SUPERVISOR	2 5	56,430	1,129	1,100	58,659
BUS SUPERVISOR	2 5	56,430	1,129	700	58,259
TRANSPORTATION SUPPORT		44,262		500	44,762
UNION Totals	20	1,167,377	32,082	28,300	1,227,759
Department Totals	20	1,167,377	32,082	28,300	1,227,759

NIAGARA FRONTIER TRANSPORTATION AUTHORITY
(ACCOUNTCO, ACCOUNTUNIT, ACCOUNT)
BUDGET WORKSHEETS - Fiscal Year 2011-12

Company 2 NFT Metro System, Inc.
Division 40 METRO TRANS. AND MAINTENANCE
Department 4058 RAIL CONTROLLERS/SUPERVISORS

Account	Description	2009-10 Actual	2010-11 Budget	2010-11 Sept. YTD Actual	2011-12 Req Budget	VARIANCE From Budget
512	TRANSPORTATION SALARY & WAGES	863,100	813,844	632,615	889,788	75,944
513	I&D SALARY & WAGES	404		205		
515	EMPLOYEE BENEFITS	576,403	559,926	449,834	626,410	66,484
580	GENERAL OFFICE	15				
TOTAL EXPENSES		1,439,922	1,373,770	1,082,654	1,516,198	142,428

40 METRO TRANS. AND MAINTENANCE
 4058 RAIL CONTROLLERS/SUPERVISORS

EMPLOYEE GROUP: PB-ALL

Job Description	Grade/Step	Base Salary	Increase Amount	Longevity Amount	Scheduled Amount
RAIL CONTROLLER	1 5	60,257	1,205	1,800	63,262
RAIL CONTROLLER	1 5	60,257	1,205	1,500	62,962
RAIL CONTROLLER	1 5	60,257	1,205	1,500	62,962
RAIL CONTROLLER	1 5	60,257	1,205	1,500	62,962
RAIL CONTROLLER	1 5	60,257	1,205	1,100	62,562
RAIL CONTROLLER	1 5	60,257	1,205	1,100	62,562
RAIL CONTROLLER	1 5	60,257	1,205	1,100	62,562
RAIL SUPERVISOR	2 5	56,430	1,129	1,800	59,359
RAIL SUPERVISOR	2 5	56,430	1,129	1,800	59,359
RAIL SUPERVISOR	2 5	56,430	1,129	1,800	59,359
RAIL SUPERVISOR	2 5	56,430	1,129	1,800	59,359
RAIL SUPERVISOR	2 5	56,430	1,129	1,500	59,059
RAIL SUPERVISOR	2 5	56,430	1,129	1,500	59,059
UNION Totals	13	760,379	15,209	19,800	795,388
Department Totals	13	760,379	15,209	19,800	795,388

PLANNING (Attachment G)

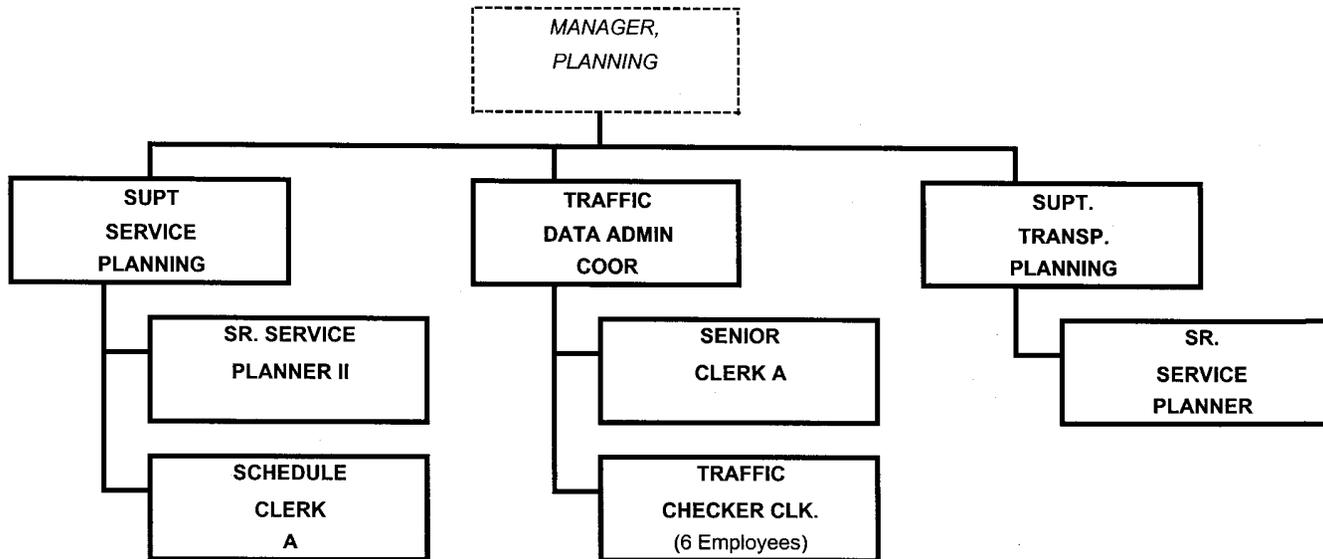

TOTAL EMPLOYEES:

NFTA	5
METRO	8
TOTAL	13

NIAGARA FRONTIER TRANSPORTATION AUTHORITY
(ACCOUNTCO, ACCOUNTUNIT, ACCOUNT)
BUDGET WORKSHEETS - Fiscal Year 2011-12

Company 2 NFT Metro System, Inc.
Division 40 METRO TRANS. AND MAINTENANCE
Department 4030 SURFACE TRANSPORTATION

Account	Description	2009-10 Actual	2010-11 Budget	2010-11 Sept. YTD Actual	2011-12 Req Budget	VARIANCE From Budget
571	CONSULTANTS/OUTSIDE SERVICES	304,983	329,795	217,434	174,869	154,926-
575	PRINTING & ADVERTISING	73,153	50,000	17,169	50,000	
576	EMPLOYEE TRAVEL	2,034	3,200	1,671	2,500	700-
580	GENERAL OFFICE	7,760	4,000	3,400	4,000	
592	DIVISION OPERATIONS	58,189-	56,969-	35,938-	72,022-	15,053-
TOTAL	EXPENSES	329,741	330,026	203,736	159,347	170,679-

NIAGARA FRONTIER TRANSPORTATION AUTHORITY
(ACCOUNTCO, ACCOUNTUNIT, ACCOUNT)
BUDGET WORKSHEETS - Fiscal Year 2011-12

Company 2 NFT Metro System, Inc.
Division 40 METRO TRANS. AND MAINTENANCE
Department 4048 SERVICE PLANNING

Account	Description	2009-10 Actual	2010-11 Budget	2010-11 Sept. YTD Actual	2011-12 Req Budget	VARIANCE From Budget
512	TRANSPORTATION SALARY & WAGES	380,702	384,634	272,502	382,384	2,250-
515	EMPLOYEE BENEFITS	255,812	264,629	192,797	269,198	4,569
571	CONSULTANTS/OUTSIDE SERVICES	620,130	654,723	490,646	634,053	20,670-
576	EMPLOYEE TRAVEL	15,635	16,000	9,774	16,000	
577	EMPLOYEE TRAINING		1,991			1,991-
580	GENERAL OFFICE	46,534	47,198	52,038	55,000	7,802
582	TRANSPORTATION EXPENSE	10,770	11,999	16,076	11,000	999-
592	DIVISION OPERATIONS	57,568-	55,255-	42,236-	55,480-	225-
TOTAL	EXPENSES	1,272,015	1,325,919	991,597	1,312,155	13,764-

40 METRO TRANS. AND MAINTENANCE
 4048 SERVICE PLANNING

EMPLOYEE GROUP: PB-ALL

Job Description	Grade/Step	Base Salary	Increase Amount	Longevity Amount	Scheduled Amount
TRAFFIC CHECKER		44,928		1,500	46,428
TRAFFIC CHECKER		44,928		1,500	46,428
TRAFFIC CHECKER		44,928		1,500	46,428
TRAFFIC CHECKER		44,928		1,200	46,128
TRAFFIC CHECKER		44,928		1,200	46,128
TRAFFIC CHECKER		44,928		900	45,828
SCHEDULE CLERK A		44,012		1,200	45,212
SENIOR CLERK A		37,252	6,592		43,804
UNION Totals	8	350,832	6,592	9,000	366,384
Department Totals	8	350,832	6,592	9,000	366,384

SPECIAL SERVICES (Attachment H)

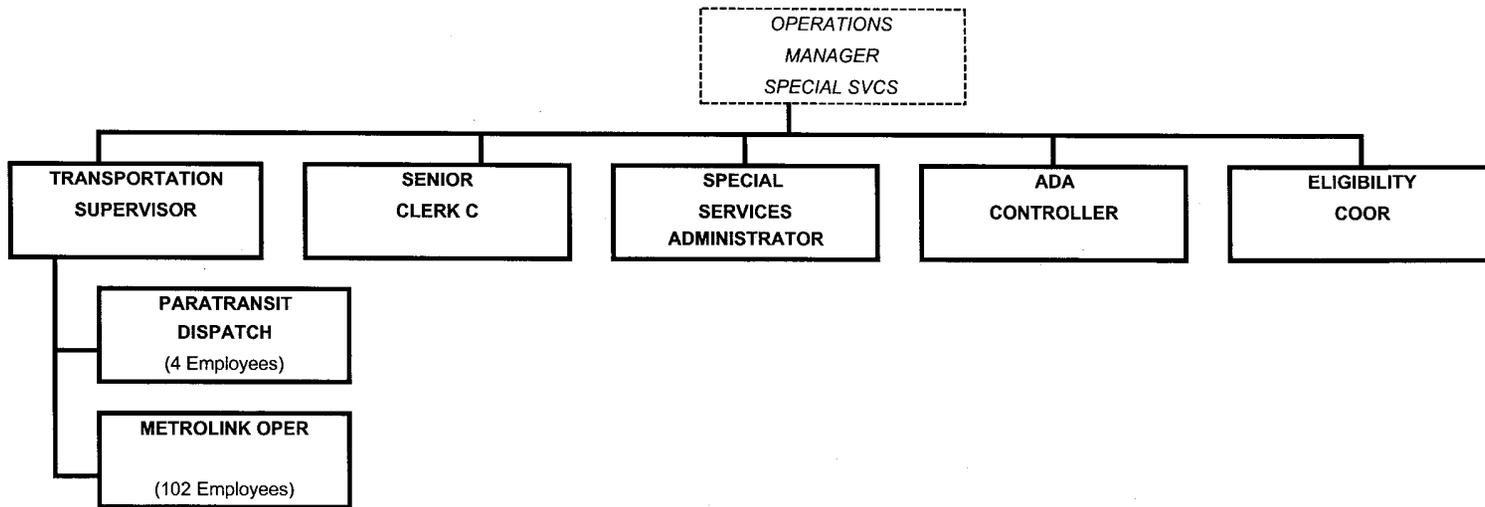

TOTAL EMPLOYEES:

NFTA	7
Metro	<u>104</u>
Total	111

NIAGARA FRONTIER TRANSPORTATION AUTHORITY
(ACCOUNTCO, ACCOUNTUNIT, ACCOUNT)
BUDGET WORKSHEETS - Fiscal Year 2011-12

Company 2 NFT Metro System, Inc.
Division 40 METRO TRANS. AND MAINTENANCE
Department 4032 METRO LINK

Account	Description	2009-10 Actual	2010-11 Budget	2010-11 Sept. YTD Actual	2011-12 Req Budget	VARIANCE From Budget
511	MAINTENANCE SALARY & WAGES	252,981	196,753	257,117	60,000	136,753-
512	TRANSPORTATION SALARY & WAGES	590,852	331,179-	396,001	4,926	336,105
514	GEN & ADMIN SALARY & WAGES	4				
515	EMPLOYEE BENEFITS	572,126	92,485-	462,303	55,708	148,193
521	REVENUE VEHICLE MAINT & TRANS	163,726	119,999	181,655	164,000	44,001
524	AUTOMOTIVE	679,677	506,034	437,861	547,002	40,968
541	INSURANCE	122		81		
580	GENERAL OFFICE	412	400	503	400	
TOTAL	EXPENSES	2,259,900	399,522	1,735,521	832,036	432,514

NIAGARA FRONTIER TRANSPORTATION AUTHORITY
(ACCOUNTCO, ACCOUNTUNIT, ACCOUNT)
BUDGET WORKSHEETS - Fiscal Year 2011-12

Company 2 NFT Metro System, Inc.
Division 40 METRO TRANS. AND MAINTENANCE
Department 4033 TROLLEY SERVICE

Account	Description	2009-10 Actual	2010-11 Budget	2010-11 Sept. YTD Actual	2011-12 Req Budget	VARIANCE From Budget
511	MAINTENANCE SALARY & WAGES	37,106	41,797	25,288	1,475	40,322-
512	TRANSPORTATION SALARY & WAGES	895	18,311-	895		18,311
515	EMPLOYEE BENEFITS	25,720	16,159	18,287	10,686-	26,845-
521	REVENUE VEHICLE MAINT & TRANS	27,198	30,000	16,250	24,575	5,425-
524	AUTOMOTIVE	15,546	32,207	17,312	35,181	2,974
582	TRANSPORTATION EXPENSE	898	1,500		900	600-
TOTAL	EXPENSES	107,363	103,352	78,032	51,445	51,907-

NIAGARA FRONTIER TRANSPORTATION AUTHORITY
(ACCOUNTCO, ACCOUNTUNIT, ACCOUNT)
BUDGET WORKSHEETS - Fiscal Year 2011-12

Company 2 NFT Metro System, Inc.
Division 40 METRO TRANS. AND MAINTENANCE
Department 4062 PARATRANSIT

Account	Description	2009-10 Actual	2010-11 Budget	2010-11 Sept. YTD Actual	2011-12 Req Budget	VARIANCE From Budget
511	MAINTENANCE SALARY & WAGES	152,613	275,028	86,669	29,000	246,028-
512	TRANSPORTATION SALARY & WAGES	2,552,951	3,688,182	1,998,794	3,136,297	551,885-
513	I&D SALARY & WAGES	589		419		
514	GEN & ADMIN SALARY & WAGES	9,668	16,983	6,844	11,372	5,611-
515	EMPLOYEE BENEFITS	1,831,633	2,738,373	1,480,940	2,236,374	501,998-
521	REVENUE VEHICLE MAINT & TRANS	105,554	127,999	86,546	108,000	19,999-
524	AUTOMOTIVE	51,839	64,425	44,203	72,838	8,413
534	TELEPHONE	448	470	218	336	134-
542	CLAIM LOSSES	39,000-	75,000	141,750-		75,000-
571	CONSULTANTS/OUTSIDE SERVICES	749,300	728,708	620,084	746,162	17,454
575	PRINTING & ADVERTISING		1,000		540	460-
576	EMPLOYEE TRAVEL		100			100-
577	EMPLOYEE TRAINING	248	1,525	1,580	248	1,277-
580	GENERAL OFFICE	66,262	76,496	61,715	82,880	6,384
582	TRANSPORTATION EXPENSE	14,672	9,999	9,675	13,000	3,001
TOTAL	EXPENSES	5,496,777	7,804,288	4,255,937	6,437,047	1,367,240-

40 METRO TRANS. AND MAINTENANCE
4062 PARATRANSIT

EMPLOYEE GROUP: PB-ALL

Job Description	Grade/Step	Base Salary	Increase Amount	Longevity Amount	Scheduled Amount
METROLINK OPERATOR		26,936	2,246		29,182
METROLINK OPERATOR		26,936	2,246		29,182
METROLINK OPERATOR		26,936	2,246		29,182
METROLINK OPERATOR		26,936	2,246		29,182
METROLINK OPERATOR		26,936	2,246		29,182
METROLINK OPERATOR		26,936	2,246		29,182
METROLINK OPERATOR		26,936	2,246		29,182
METROLINK OPERATOR		26,936	2,246		29,182
METROLINK OPERATOR		26,936	2,246		29,182
METROLINK OPERATOR		26,936	2,246		29,182
METROLINK OPERATOR		26,936	2,246		29,182
METROLINK OPERATOR		26,936	2,246		29,182
METROLINK OPERATOR		26,936	2,246		29,182
UNION Totals	104	3,141,411	92,086	9,500	3,242,997
Department Totals	104	3,141,411	92,086	9,500	3,242,997

CUSTOMER SERVICE (Attachment I)

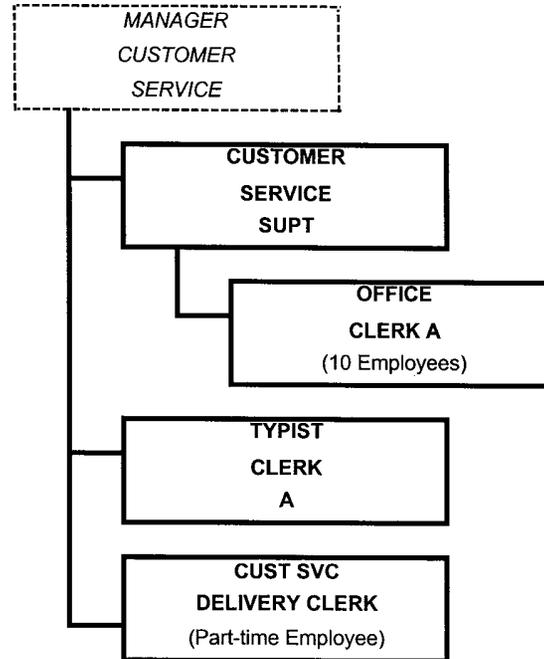

TOTAL EMPLOYEES:

	FT	PT	Total
NFTA	1	0	1
Metro	<u>11</u>	<u>1</u>	<u>12</u>
Total	12	1	13

NIAGARA FRONTIER TRANSPORTATION AUTHORITY
(ACCOUNTCO, ACCOUNTUNIT, ACCOUNT)
BUDGET WORKSHEETS - Fiscal Year 2011-12

Company 2 NFT Metro System, Inc.
Division 40 METRO TRANS. AND MAINTENANCE
Department 4041 CUSTOMER SERVICE

Account	Description	2009-10 Actual	2010-11 Budget	2010-11 Sept. YTD Actual	2011-12 Req Budget	VARIANCE From Budget
514	GEN & ADMIN SALARY & WAGES	458,427	429,808	335,597	433,992	4,184
515	EMPLOYEE BENEFITS	309,995	295,708	238,936	305,530	9,822
523	IMPROVEMENTS & REPLACEMENTS	1,000	1,000	803	1,000	
571	CONSULTANTS/OUTSIDE SERVICES	182,933	196,873	118,600	212,898	16,025
575	PRINTING & ADVERTISING	6,394	6,498	2,910	6,000	498-
576	EMPLOYEE TRAVEL	26	200	19	50	150-
577	EMPLOYEE TRAINING	507	2,763	41	507	2,256-
580	GENERAL OFFICE	68,054	83,197	71,040	81,400	1,797-
592	DIVISION OPERATIONS	115,122-	114,810-	85,815-	116,945-	2,135-
TOTAL EXPENSES		912,214	901,237	682,131	924,432	23,195

40 METRO TRANS. AND MAINTENANCE
4041 CUSTOMER SERVICE

EMPLOYEE GROUP: PB-ALL

Job Description	Grade/Step	Base Salary	Increase Amount	Longevity Amount	Scheduled Amount
OFFICE CLERK A		42,536		1,500	44,036
OFFICE CLERK A		42,536		1,500	44,036
OFFICE CLERK A		42,536		1,500	44,036
OFFICE CLERK A		42,536		1,500	44,036
OFFICE CLERK A		42,536		1,200	43,736
OFFICE CLERK A		42,536		1,200	43,736
OFFICE CLERK A		42,536		900	43,436
OFFICE CLERK A		42,536		900	43,436
OFFICE CLERK A		42,536		700	43,236
OFFICE CLERK A		42,536		500	43,036
TYPIST CLERK A		27,830	2,134		29,964
UNION Totals	11	453,190	2,134	11,400	466,724
Department Totals	11	453,190	2,134	11,400	466,724

RAIL MAINTENANCE (Attachment J)

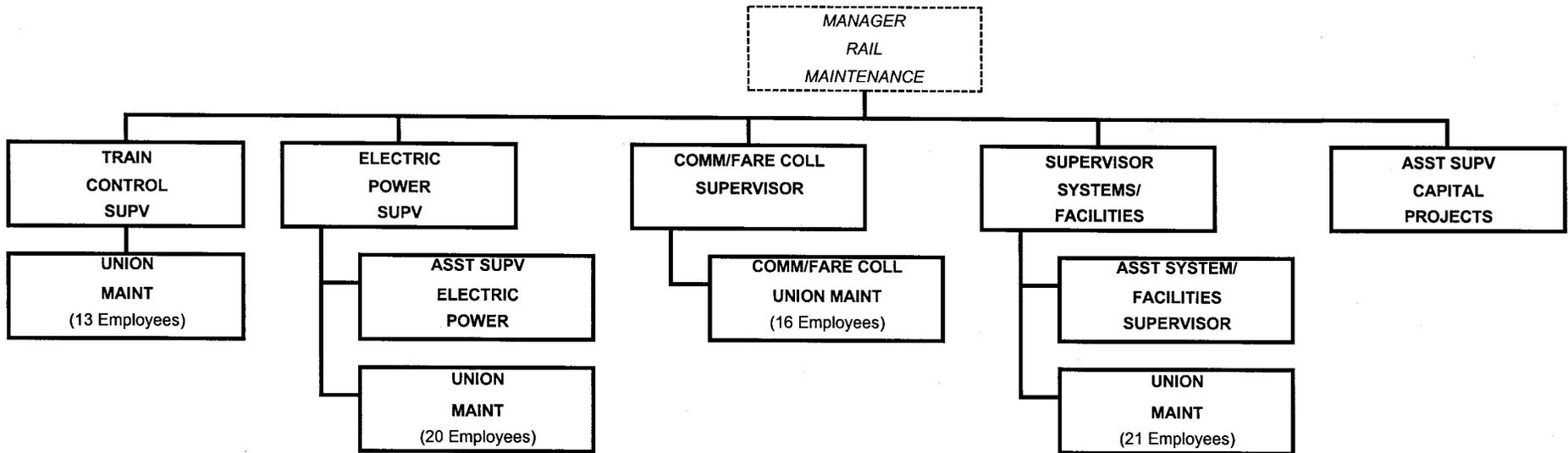

TOTAL EMPLOYEES:

NFTA	7
Metro	70
Total	77

NIAGARA FRONTIER TRANSPORTATION AUTHORITY
(ACCOUNTCO, ACCOUNTUNIT, ACCOUNT)
BUDGET WORKSHEETS - Fiscal Year 2011-12

Company 2 NFT Metro System, Inc.
Division 40 METRO TRANS. AND MAINTENANCE
Department 4050 RAIL MAINTENANCE

Account	Description	2009-10 Actual	2010-11 Budget	2010-11 Sept. YTD Actual	2011-12 Req Budget	VARIANCE From Budget
511	MAINTENANCE SALARY & WAGES	3,317,222	3,391,217	2,467,980	3,402,108	10,891
514	GEN & ADMIN SALARY & WAGES	3,962		734	2,400	2,400
515	EMPLOYEE BENEFITS	2,257,753	2,333,157	1,757,647	2,396,773	63,616
521	REVENUE VEHICLE MAINT & TRANS	4,575-		6,584-	3,772-	3,772-
522	NON-REV VEHICLE MAINT & REPAIR	31,521	50,999	25,730	37,500	13,499-
524	AUTOMOTIVE	761,823	2,818,957	584,107	851,497	32,540
525	FACILITIES	417,760	415,000	325,571	425,000	10,000
531	ELECTRIC POWER	530,527	551,373	396,252	618,890	67,517
532	GAS	63,729	65,594	20,980	66,915	1,321
533	WATER	19,145	20,101	44,224	27,016	6,915
553	POLICE PROTECTION	91,118	93,000	68,995	93,000	
571	CONSULTANTS/OUTSIDE SERVICES	1,607,451	1,857,696	1,124,462	1,711,634	146,062-
572	RENT EXPENSE	7,800	7,800	5,850	7,800	
577	EMPLOYEE TRAINING	6,041		521	5,000	5,000
580	GENERAL OFFICE	19,871	24,999	19,955	25,000	1
591	PROJECTS	6,556-			6,600-	6,600-
TOTAL	EXPENSES	9,124,592	9,629,893	6,836,424	9,660,161	30,268

40 METRO TRANS. AND MAINTENANCE
4050 RAIL MAINTENANCE

EMPLOYEE GROUP: PB-ALL

Job Description	Grade/Step	Base Salary	Increase Amount	Longevity Amount	Scheduled Amount
LEADER		48,713		1,500	50,213
LEADER		48,713		1,200	49,913
LEADER		48,713		1,200	49,913
SPECIALIST		47,840		1,500	49,340
SPECIALIST		47,840		1,500	49,340
SPECIALIST		47,840		1,500	49,340
SPECIALIST		47,840		1,200	49,040
SPECIALIST		47,840		1,200	49,040
SPECIALIST		47,840		1,200	49,040
SPECIALIST		47,840		1,200	49,040
SPECIALIST		47,840		1,200	49,040
SPECIALIST		47,840		1,200	49,040
SPECIALIST		47,840		1,200	49,040
SPECIALIST		47,840		1,200	49,040
SPECIALIST		47,840		1,200	49,040
SPECIALIST		47,840		1,200	49,040
LEADER		48,713		300	49,013
LEADER		48,713		300	49,013
SPECIALIST		47,840		900	48,740
SPECIALIST		47,840		900	48,740
MECHANIC A		46,820		1,500	48,320
MECHANIC A		46,820		1,500	48,320
MECHANIC A		46,820		1,500	48,320
MECHANIC A		46,820		1,500	48,320
MECHANIC A		46,820		1,500	48,320
MECHANIC A		46,820		1,500	48,320
SPECIALIST		47,840		300	48,140
SPECIALIST		47,840		300	48,140
SPECIALIST		47,840		300	48,140
SPECIALIST		47,840		300	48,140
SPECIALIST		47,840		300	48,140
MECHANIC A		46,820		1,200	48,020
MECHANIC A		46,820		1,200	48,020
MECHANIC A		46,820		1,200	48,020
SPECIALIST		47,840			47,840
MECHANIC A		46,820		900	47,720
MECHANIC A		46,820		500	47,320
MECHANIC A		46,820		500	47,320
SPECIALIST		46,820		500	47,320
MECHANIC A		46,820		500	47,320
MECHANIC A		46,820		500	47,320
MECHANIC A		46,820		300	47,120
MECHANIC A		42,140	4,679		46,819
HELPER WITH TOOLS		43,804		1,200	45,004
HELPER WITH TOOLS		43,804		1,200	45,004
HELPER WITH TOOLS		43,804		700	44,504

40 METRO TRANS. AND MAINTENANCE
4050 RAIL MAINTENANCE

EMPLOYEE GROUP: PB-ALL

Job Description	Grade/Step	Base Salary	Increase Amount	Longevity Amount	Scheduled Amount
HELPER WITH TOOLS		43,804		500	44,304
SENIOR CLERK A		43,846		300	44,146
MECHANIC A		39,811	2,329		42,140
SPECIALIST		35,880	2,392		38,272
MECHANIC A		35,110	2,349		37,459
MECHANIC A		35,110	2,349		37,459
MECHANIC A		35,110	2,349		37,459
HELPER		31,553	5,575		37,128
PORTER		34,777		500	35,277
PORTER		34,777		300	35,077
PORTER		34,777		300	35,077
PORTER		34,777		300	35,077
PORTER		34,777		300	35,077
PORTER		34,777		300	35,077
PORTER		34,777		300	35,077
PORTER		34,777		300	35,077
HELPER		27,851	3,702		31,553
PORTER		26,083	3,477		29,560
PORTER		24,336	1,747		26,083
PORTER		24,336	1,747		26,083
PORTER		22,609	1,727		24,336
PORTER		22,609	1,727		24,336
PORTER		20,862	1,747		22,609
PORTER		20,862	1,747		22,609
UNION Totals	70	2,938,865	39,643	47,100	3,025,608
Department Totals	70	2,938,865	39,643	47,100	3,025,608

SOUTH PARK (Attachment K)

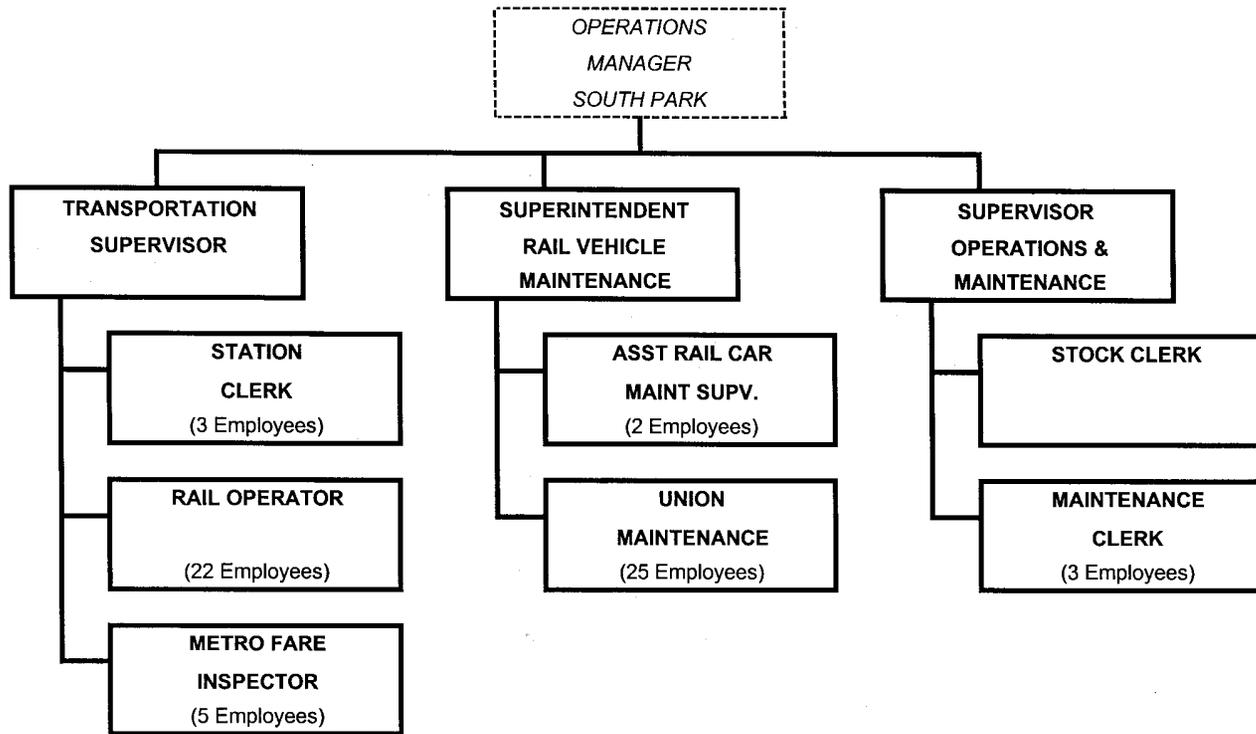

TOTAL EMPLOYEES:

NFTA	5
Metro	<u>59</u>
Total	64

NIAGARA FRONTIER TRANSPORTATION AUTHORITY
(ACCOUNTCO, ACCOUNTUNIT, ACCOUNT)
BUDGET WORKSHEETS - Fiscal Year 2011-12

Company 2 NFT Metro System, Inc.
Division 40 METRO TRANS. AND MAINTENANCE
Department 4051 STOREROOM- RAIL

Account	Description	2009-10 Actual	2010-11 Budget	2010-11 Sept. YTD Actual	2011-12 Req Budget	VARIANCE From Budget
514	GEN & ADMIN SALARY & WAGES	202,345	203,980	152,743	197,578	6,402-
515	EMPLOYEE BENEFITS	138,595	140,338	109,209	139,094	1,243-
527	ENVIRONMENTAL	15,087	5,999	15,600	6,500	501
571	CONSULTANTS/OUTSIDE SERVICES	100,979	122,887	79,561	118,913	3,974-
580	GENERAL OFFICE	23,756	13,000	20,527	13,300	300
591	PROJECTS	804-				
TOTAL EXPENSES		479,958	486,204	377,640	475,385	10,818-

40 METRO TRANS. AND MAINTENANCE
4051 STOREROOM- RAIL

EMPLOYEE GROUP: PB-ALL

Job Description	Grade/Step	Base Salary	Increase Amount	Longevity Amount	Scheduled Amount
STOCK CLERK		44,262		1,500	45,762
MAINTENANCE CLERK		42,972		1,500	44,472
MAINTENANCE CLERK		42,972		1,200	44,172
MAINTENANCE CLERK		42,972		700	43,672
UNION Totals	4	173,178		4,900	178,078
Department Totals	4	173,178		4,900	178,078

NIAGARA FRONTIER TRANSPORTATION AUTHORITY
(ACCOUNTCO, ACCOUNTUNIT, ACCOUNT)
BUDGET WORKSHEETS - Fiscal Year 2011-12

Company 2 NFT Metro System, Inc.
Division 40 METRO TRANS. AND MAINTENANCE
Department 4054 RAIL CAR MAINTENENCE

Account	Description	2009-10 Actual	2010-11 Budget	2010-11 Sept. YTD Actual	2011-12 Req Budget	VARIANCE From Budget
511	MAINTENANCE SALARY & WAGES	1,179,298	1,276,776	832,910	1,107,911	168,865-
514	GEN & ADMIN SALARY & WAGES	1,369		368	1,115	1,115
515	EMPLOYEE BENEFITS	799,810	878,421	595,970	780,754	97,666-
521	REVENUE VEHICLE MAINT & TRANS	272,642	270,000	210,075	263,000	7,000-
525	FACILITIES	218		7,869		
571	CONSULTANTS/OUTSIDE SERVICES	433,161	454,741	354,150	462,496	7,755
577	EMPLOYEE TRAINING	183	141			141-
580	GENERAL OFFICE	3,342	5,999	3,300	5,000	999-
591	PROJECTS	3,449-			3,555-	3,555-
TOTAL EXPENSES		2,686,574	2,886,078	2,004,642	2,616,721	269,356-

40 METRO TRANS. AND MAINTENANCE
4054 RAIL CAR MAINTENENCE

EMPLOYEE GROUP: PB-ALL

Job Description	Grade/Step	Base Salary	Increase Amount	Longevity Amount	Scheduled Amount
LEADER		48,713		1,200	49,913
SPECIALIST		47,840		1,500	49,340
SPECIALIST		47,840		1,500	49,340
SPECIALIST		47,840		1,200	49,040
SPECIALIST		47,840		1,200	49,040
SPECIALIST		47,840		1,200	49,040
SPECIALIST		47,840		1,200	49,040
SPECIALIST		47,840		900	48,740
MECHANIC A		46,820		1,500	48,320
MECHANIC A		46,820		1,500	48,320
MECHANIC A		46,820		900	47,720
MECHANIC A		46,820		900	47,720
MECHANIC A		46,820		900	47,720
MECHANIC A		46,820		500	47,320
MECHANIC A		42,140	4,679		46,819
MECHANIC A		42,140	4,679		46,819
HELPER		43,492		1,500	44,992
HELPER WITH TOOLS		43,804		300	44,104
MECHANIC A		37,460	2,350		39,810
HELPER		37,128		700	37,828
HELPER		37,128		700	37,828
HELPER		37,128		500	37,628
MECHANIC A		35,110	2,350		37,460
MECHANIC A		35,110	2,350		37,460
HELPER		24,128	1,872		26,000
UNION Totals	25	1,079,281	18,280	19,800	1,117,361
Department Totals	25	1,079,281	18,280	19,800	1,117,361

NIAGARA FRONTIER TRANSPORTATION AUTHORITY
(ACCOUNTCO, ACCOUNTUNIT, ACCOUNT)
BUDGET WORKSHEETS - Fiscal Year 2011-12

Company 2 NFT Metro System, Inc.
Division 40 METRO TRANS. AND MAINTENANCE
Department 4055 SOUTH PARK STATION

Account	Description	2009-10 Actual	2010-11 Budget	2010-11 Sept. YTD Actual	2011-12 Req Budget	VARIANCE From Budget
512	TRANSPORTATION SALARY & WAGES	1,180,635	1,141,180	927,186	1,202,551	61,371
514	GEN & ADMIN SALARY & WAGES	261		8,140		
515	EMPLOYEE BENEFITS	823,661	793,387	666,732	846,595	53,208
571	CONSULTANTS/OUTSIDE SERVICES	88,746	94,165	70,315	95,096	931
582	TRANSPORTATION EXPENSE	35,510	38,000	37,293	38,000	
592	DIVISION OPERATIONS	62,888	78,327	46,942	70,881	7,446-
TOTAL	EXPENSES	2,191,701	2,145,059	1,756,608	2,253,123	108,064

40 METRO TRANS. AND MAINTENANCE
4055 SOUTH PARK STATION

EMPLOYEE GROUP: PB-ALL

Job Description	Grade/Step	Base Salary	Increase Amount	Longevity Amount	Scheduled Amount
OPERATOR		46,816		1,500	48,316
OPERATOR		46,816		1,500	48,316
OPERATOR		46,816		1,200	48,016
OPERATOR		46,816		1,200	48,016
OPERATOR		46,816		900	47,716
OPERATOR		46,816		700	47,516
OPERATOR		46,816		700	47,516
OPERATOR		46,816		700	47,516
OPERATOR		46,816		500	47,316
OPERATOR		46,816		500	47,316
OPERATOR		46,816		500	47,316
OPERATOR		46,816		500	47,316
OPERATOR		46,816		500	47,316
OPERATOR		46,816		500	47,316
OPERATOR		46,816		500	47,316
OPERATOR		46,816		500	47,316
OPERATOR		46,816		300	47,116
OPERATOR		46,816		300	47,116
OPERATOR		46,816		300	47,116
OPERATOR		46,816		300	47,116
OPERATOR		39,793	7,023	300	47,116
OPERATOR		46,816			46,816
STATION CLERK		45,073		1,500	46,573
STATION CLERK		45,073		1,500	46,573
STATION CLERK		45,073		900	45,973
UNION Totals	25	1,158,148	7,023	17,800	1,182,971
Department Totals	25	1,158,148	7,023	17,800	1,182,971

NIAGARA FRONTIER TRANSPORTATION AUTHORITY
(ACCOUNTCO, ACCOUNTUNIT, ACCOUNT)
BUDGET WORKSHEETS - Fiscal Year 2011-12

Company 2 NFT Metro System, Inc.
Division 40 METRO TRANS. AND MAINTENANCE
Department 4057 RAIL TICKET INSPECTORS

Account	Description	2009-10 Actual	2010-11 Budget	2010-11 Sept. YTD Actual	2011-12 Req Budget	VARIANCE From Budget
512	TRANSPORTATION SALARY & WAGES	165,312	182,788	127,658	188,765	5,977
515	EMPLOYEE BENEFITS	109,443	125,759	89,581	132,890	7,131
	TOTAL EXPENSES	274,755	308,547	217,239	321,655	13,108

40 METRO TRANS. AND MAINTENANCE
 4057 RAIL TICKET INSPECTORS

EMPLOYEE GROUP: PB-ALL

Job Description	Grade/Step	Base Salary	Increase Amount	Longevity Amount	Scheduled Amount
METRO FARE INSPECTOR		43,513		1,200	44,713
METRO FARE INSPECTOR		43,513		1,200	44,713
METRO FARE INSPECTOR		43,513		500	44,013
METRO FARE INSPECTOR		43,513		300	43,813
METRO FARE INSPECTOR		43,513			43,513
UNION Totals	5	217,565		3,200	220,765
Department Totals	5	217,565		3,200	220,765

NIAGARA FRONTIER TRANSPORTATION AUTHORITY
(ACCOUNTCO, ACCOUNTUNIT, ACCOUNT)
BUDGET WORKSHEETS - Fiscal Year 2011-12

Company 2 NFT Metro System, Inc.
Division 40 METRO TRANS. AND MAINTENANCE
Department 4059 RAIL OVERHEAD

Account	Description	2009-10 Actual	2010-11 Budget	2010-11 Sept. YTD Actual	2011-12 Req Budget	VARIANCE From Budget
534	TELEPHONE	27,177	28,535	18,545	31,091	2,556
541	INSURANCE	712,742	772,252	521,368	717,880	54,372-
553	POLICE PROTECTION	5,297,706	4,141,886	3,765,783	4,648,690	506,804
592	DIVISION OPERATIONS	712,781	677,170	542,086	717,091	39,921
TOTAL EXPENSES		6,750,406	5,619,843	4,847,782	6,114,752	494,909

FY 2011 / 2012 THROUGH 2015 / 2016

CAPITAL PROJECTS

BUS MAINTENANCE

PROJECT TITLE	PROJECT NUMBER	PRTY CL	JUST. CL	FUND SOURCE	TOTAL PROJECT BUDGET	PROJECT LIFE ACTUAL AS OF 7/19/10	TOTAL FORECASTED SPENDING 7/20/10	FISCAL YEAR 2011/2012	FISCAL YEAR 2012/2013	FISCAL YEAR 2013/2014	FISCAL YEAR 2014/2015	FISCAL YEAR 2015/2016	OUT YEARS
BUS MAINTENANCE													
EPA ENGINE REBUILD KITS (X612)	2-3365		NR	FTA	\$1,477,303	\$130,743	\$86,560	\$160,000	\$220,000	\$220,000	\$220,000	\$220,000	\$220,000
				NYSDOT	\$184,663	\$16,343	\$10,820	\$20,000	\$27,500	\$27,500	\$27,500	\$27,500	\$27,500
				NFTA	\$184,663	\$16,343	\$10,820	\$20,000	\$27,500	\$27,500	\$27,500	\$27,500	\$27,500
				TOTAL	\$1,846,629	\$163,429	\$108,200	\$200,000	\$275,000	\$275,000	\$275,000	\$275,000	\$275,000
FLEET WATCH	--		NI	FTA	\$640,000	\$0	\$0	\$0	\$0	\$0	\$640,000	\$0	\$0
				NYSDOT	\$80,000	\$0	\$0	\$0	\$0	\$0	\$80,000	\$0	\$0
				NFTA	\$80,000	\$0	\$0	\$0	\$0	\$0	\$80,000	\$0	\$0
				TOTAL	\$800,000	\$0	\$0	\$0	\$0	\$0	\$800,000	\$0	\$0
DATA & COMMUNICATION COMPONENTS (5307)	2-3362		NR	FTA	\$491,999	\$25,396	\$100,603	\$66,000	\$60,000	\$60,000	\$60,000	\$60,000	\$60,000
	2-3383			NYSDOT	\$61,500	\$3,175	\$12,575	\$8,250	\$7,500	\$7,500	\$7,500	\$7,500	\$7,500
				NFTA	\$61,500	\$3,175	\$12,575	\$8,250	\$7,500	\$7,500	\$7,500	\$7,500	\$7,500
				TOTAL	\$614,999	\$31,745	\$125,754	\$82,500	\$75,000	\$75,000	\$75,000	\$75,000	\$75,000
ACQUIRE MISC. SUPPORT EQUIPMENT	2-3367		NR	FTA	\$1,320,192	\$82,099	\$190,315	\$247,778	\$160,000	\$160,000	\$160,000	\$160,000	\$160,000
	2-3381			NYSDOT	\$165,024	\$10,262	\$23,789	\$30,972	\$20,000	\$20,000	\$20,000	\$20,000	\$20,000
				NFTA	\$165,024	\$10,262	\$23,789	\$30,972	\$20,000	\$20,000	\$20,000	\$20,000	\$20,000
				TOTAL	\$1,650,240	\$102,624	\$237,894	\$309,722	\$200,000	\$200,000	\$200,000	\$200,000	\$200,000
REPLACEMENT HYBRID BUS BATTERIES (Not included in ECHDC Reimbursement Plan)	--		NR	FTA	\$1,640,000	\$0	\$0	\$0	\$120,000	\$1,080,000	\$440,000	\$0	\$0
				NYSDOT	\$205,000	\$0	\$0	\$0	\$15,000	\$135,000	\$55,000	\$0	\$0
				NFTA	\$205,000	\$0	\$0	\$0	\$15,000	\$135,000	\$55,000	\$0	\$0
				TOTAL	\$2,050,000	\$0	\$0	\$0	\$150,000	\$1,350,000	\$550,000	\$0	\$0
DERA 2006 Year 1	2-3345		M	FTA	\$520,000	\$435,052	\$44,948	\$40,000	\$0	\$0	\$0	\$0	\$0
				NYSDOT	\$65,000	\$54,382	\$5,619	\$5,000	\$0	\$0	\$0	\$0	\$0
				NFTA	\$65,000	\$54,382	\$5,619	\$5,000	\$0	\$0	\$0	\$0	\$0
				TOTAL	\$650,000	\$543,815	\$56,185	\$50,000	\$0	\$0	\$0	\$0	\$0
FLEETLYNX UPGRADE (Various)	2-3343		NR	FTA	\$1,701,198	\$1,247,385	\$253,813	\$200,000	\$0	\$0	\$0	\$0	\$0
				NYSDOT	\$212,650	\$155,923	\$31,727	\$25,000	\$0	\$0	\$0	\$0	\$0
				NFTA	\$212,650	\$155,923	\$31,727	\$25,000	\$0	\$0	\$0	\$0	\$0
				TOTAL	\$2,126,497	\$1,559,231	\$317,266	\$250,000	\$0	\$0	\$0	\$0	\$0

BUS MAINTENANCE

PROJECT TITLE	PROJECT NUMBER	PRTY CL	JUST. CL	FUND SOURCE	TOTAL PROJECT BUDGET	PROJECT LIFE ACTUAL AS OF 7/19/10	TOTAL FORECASTED SPENDING 7/20/10	FISCAL YEAR 2011/2012	FISCAL YEAR 2012/2013	FISCAL YEAR 2013/2014	FISCAL YEAR 2014/2015	FISCAL YEAR 2015/2016	OUT YEARS
BUS ROOF ACCESS (Various)	--		M	FTA	\$48,000	\$0	\$0	\$48,000	\$0	\$0	\$0	\$0	\$0
				NYSDOT	\$6,000	\$0	\$0	\$6,000	\$0	\$0	\$0	\$0	\$0
				NFTA	\$6,000	\$0	\$0	\$6,000	\$0	\$0	\$0	\$0	\$0
				TOTAL	\$60,000	\$0	\$0	\$60,000	\$0	\$0	\$0	\$0	\$0
VEHICLES RADIO EQUIP.	2-3361		NR	FTA	\$84,000	\$0	\$84,000	\$0	\$0	\$0	\$0	\$0	\$0
				NYSDOT	\$10,500	\$0	\$10,500	\$0	\$0	\$0	\$0	\$0	\$0
				NFTA	\$10,500	\$0	\$10,500	\$0	\$0	\$0	\$0	\$0	\$0
				TOTAL	\$105,000	\$0	\$105,000	\$0	\$0	\$0	\$0	\$0	\$0

FTA	\$7,922,692	\$1,920,675	\$760,239	\$761,778	\$560,000	\$1,520,000	\$1,520,000	\$440,000	\$440,000
NYSDOT	\$990,337	\$240,084	\$95,030	\$95,222	\$70,000	\$190,000	\$190,000	\$55,000	\$55,000
NFTA	\$990,337	\$240,084	\$95,030	\$95,222	\$70,000	\$190,000	\$190,000	\$55,000	\$55,000
TOTAL	\$9,903,365	\$2,400,844	\$950,299	\$952,222	\$700,000	\$1,900,000	\$1,900,000	\$550,000	\$550,000

BUS VEHICLE

PROJECT TITLE	PROJECT NUMBER	PRTY CL	JUST. CL	FUND SOURCE	TOTAL PROJECT BUDGET	PROJECT LIFE ACTUAL AS OF 7/19/10	TOTAL FORECASTED SPENDING 7/20/10	FISCAL YEAR 2011/2012	FISCAL YEAR 2012/2013	FISCAL YEAR 2013/2014	FISCAL YEAR 2014/2015	FISCAL YEAR 2015/2016	OUT YEARS
BUS VEHICLE													
PURCHASE (11) BUSES (#1001-1011-HYBRID)	2-3353		NR	FTA	\$5,040,001	\$5,034,674	\$5,327	\$0	\$0	\$0	\$0	\$0	\$0
				NYSDOT	\$630,000	\$629,334	\$666	\$0	\$0	\$0	\$0	\$0	\$0
				NFTA	\$630,000	\$629,334	\$666	\$0	\$0	\$0	\$0	\$0	\$0
				TOTAL	\$6,300,001	\$6,293,342	\$6,659	\$0	\$0	\$0	\$0	\$0	\$0
(56) BUSES (#1012-1067)-STIMULUS FUNDS(DIESEL)	2-3356		NR	FTA	\$24,430,788	\$241,597	\$24,189,191	\$0	\$0	\$0	\$0	\$0	\$0
(21) HYBRID BUSES - (#1101 - 1121)	2-3374		NR	FTA	\$10,315,033	\$0	\$0	\$10,315,033	\$0	\$0	\$0	\$0	\$0
				NYSDOT	\$1,289,379	\$0	\$0	\$1,289,379	\$0	\$0	\$0	\$0	\$0
				NFTA	\$1,289,379	\$0	\$0	\$1,289,379	\$0	\$0	\$0	\$0	\$0
				TOTAL	\$12,893,791	\$0	\$0	\$12,893,791	\$0	\$0	\$0	\$0	\$0
(3) HYBRID BUSES - (#1122 - 1124)	2-3372		NR	FTA	\$1,488,750	\$0	\$0	\$1,488,750	\$0	\$0	\$0	\$0	\$0
				NYSDOT	\$186,094	\$0	\$0	\$186,094	\$0	\$0	\$0	\$0	\$0
				NFTA	\$186,094	\$0	\$0	\$186,094	\$0	\$0	\$0	\$0	\$0
				TOTAL	\$1,860,938	\$0	\$0	\$1,860,938	\$0	\$0	\$0	\$0	\$0
(5) REPLACEMENT 40-FT. BUSES (#1125 - 1129)	2-3371		NR	FTA	\$2,644,780	\$0	\$0	\$2,644,780	\$0	\$0	\$0	\$0	\$0
				NYSDOT	\$330,598	\$0	\$0	\$330,598	\$0	\$0	\$0	\$0	\$0
				NFTA	\$330,598	\$0	\$0	\$330,598	\$0	\$0	\$0	\$0	\$0
				TOTAL	\$3,305,975	\$0	\$0	\$3,305,975	\$0	\$0	\$0	\$0	\$0
(1) REPLACEMENT 40-FT. BUS #1130	2-3379		NR	FTA	\$475,000	\$0	\$0	\$475,000	\$0	\$0	\$0	\$0	\$0
				NYSDOT	\$59,375	\$0	\$0	\$59,375	\$0	\$0	\$0	\$0	\$0
				NFTA	\$59,375	\$0	\$0	\$59,375	\$0	\$0	\$0	\$0	\$0
				TOTAL	\$593,750	\$0	\$0	\$593,750	\$0	\$0	\$0	\$0	\$0
FUTURE BIG BUSES AS LIFE EXPIRED	--		NR	FTA	\$57,096,000	\$0	\$0	\$0	\$29,280,000	\$9,760,000	\$18,056,000	\$0	\$0
(\$610K FOR A HYBRID BUS)				NYSDOT	\$7,137,000	\$0	\$0	\$0	\$3,660,000	\$1,220,000	\$2,257,000	\$0	\$0
				NFTA	\$7,137,000	\$0	\$0	\$0	\$3,660,000	\$1,220,000	\$2,257,000	\$0	\$0
				TOTAL	\$71,370,000	\$0	\$0	\$0	\$36,600,000	\$12,200,000	\$22,570,000	\$0	\$0
									(60)	(20)	(37)		
PURCHASE (13) HYBRID PASSENGER BUSES	--		NR	FTA	\$6,999,999	\$0	\$0	\$0	\$6,999,999	\$0	\$0	\$0	\$0
				NYSDOT	\$843,373	\$0	\$0	\$0	\$843,373	\$0	\$0	\$0	\$0
				NFTA	\$590,361	\$0	\$0	\$0	\$590,361	\$0	\$0	\$0	\$0
				TOTAL	\$8,433,734	\$0	\$0	\$0	\$8,433,734	\$0	\$0	\$0	\$0

CAPITAL PROJECTS

BUS VEHICLE

PROJECT TITLE	PROJECT NUMBER	PRTY CL	JUST. CL	FUND SOURCE	TOTAL PROJECT BUDGET	PROJECT LIFE ACTUAL AS OF 7/19/10	TOTAL FORECASTED SPENDING 7/20/10	FISCAL YEAR 2011/2012	FISCAL YEAR 2012/2013	FISCAL YEAR 2013/2014	FISCAL YEAR 2014/2015	FISCAL YEAR 2015/2016	OUT YEARS
(10) SMALL BUSES	2-3380		NR	FTA	\$1,030,720	\$0	\$1,030,720	\$0	\$0	\$0	\$0	\$0	\$0
				NYS DOT	\$128,840	\$0	\$128,840	\$0	\$0	\$0	\$0	\$0	\$0
				NFTA	\$128,840	\$0	\$128,840	\$0	\$0	\$0	\$0	\$0	\$0
				TOTAL	\$1,288,400	\$0	\$1,288,400	\$0	\$0	\$0	\$0	\$0	\$0
BUS - ROLLING STOCK (5307) SMALL BUS REPLACE.	--		NR	FTA	\$624,000	\$0	\$0	\$0	\$208,000	\$416,000	\$0	\$0	\$0
				NYS DOT	\$78,000	\$0	\$0	\$0	\$26,000	\$52,000	\$0	\$0	\$0
				NFTA	\$78,000	\$0	\$0	\$0	\$26,000	\$52,000	\$0	\$0	\$0
				TOTAL	\$780,000	\$0	\$0	\$0	\$260,000	\$520,000	\$0	\$0	\$0
									(2)	(4)			
FUTURE SMALL BUSES AS LIFE EXPIRED (\$130K EACH)	--		NR	FTA	\$4,368,000	\$0	\$0	\$0	\$2,808,000	\$1,560,000	\$0	\$0	\$0
				NYS DOT	\$546,000	\$0	\$0	\$0	\$351,000	\$195,000	\$0	\$0	\$0
				NFTA	\$546,000	\$0	\$0	\$0	\$351,000	\$195,000	\$0	\$0	\$0
				TOTAL	\$5,460,000	\$0	\$0	\$0	\$3,510,000	\$1,950,000	\$0	\$0	\$0
									(27)	(15)			
(5) METROLINK TROLLEYS 08/09 - REPLACEMENT	--		NR	FTA	\$1,600,000	\$0	\$0	\$0	\$0	\$1,600,000	\$0	\$0	\$0
				NYS DOT	\$200,000	\$0	\$0	\$0	\$0	\$200,000	\$0	\$0	\$0
				NFTA	\$200,000	\$0	\$0	\$0	\$0	\$200,000	\$0	\$0	\$0
				TOTAL	\$2,000,000	\$0	\$0	\$0	\$0	\$2,000,000	\$0	\$0	\$0
ACQUIRE SUPPORT VEHICLES *	2-3368		NR	FTA	\$767,682	\$38,782	\$260,900	\$160,000	\$88,000	\$40,000	\$60,000	\$60,000	\$60,000
	2-3382			NYS DOT	\$95,960	\$4,848	\$32,613	\$20,000	\$11,000	\$5,000	\$7,500	\$7,500	\$7,500
				NFTA	\$95,960	\$4,848	\$32,613	\$20,000	\$11,000	\$5,000	\$7,500	\$7,500	\$7,500
				TOTAL	\$959,603	\$48,478	\$326,125	\$200,000	\$110,000	\$50,000	\$75,000	\$75,000	\$75,000

* - Total forecast spending includes \$200,000 from FFY 10 Grant

FYE 11 - (1) Tow Truck, (1) Sign Truck (1) Vault Truck

FYE 12 - (2) Pickups-(Maint) (2) SUV's or Pickups (Operations)

Rebudget \$200,000 to FYE 12

FTA	\$116,880,754	\$5,315,053	\$25,486,138	\$15,083,563	\$39,383,999	\$13,376,000	\$18,116,000	\$60,000	\$60,000
NYS DOT	\$11,524,619	\$634,182	\$162,118	\$1,885,445	\$4,891,373	\$1,672,000	\$2,264,500	\$7,500	\$7,500
NFTA	\$11,271,607	\$634,182	\$162,118	\$1,885,445	\$4,638,361	\$1,672,000	\$2,264,500	\$7,500	\$7,500
TOTAL	\$139,676,980	\$6,583,417	\$25,810,375	\$18,854,454	\$48,913,734	\$16,720,000	\$22,645,000	\$75,000	\$75,000

BUS ENGINEERING

PROJECT TITLE	PROJECT NUMBER	PRTY CL	JUST. CL	FUND SOURCE	TOTAL PROJECT BUDGET	PROJECT LIFE ACTUAL AS OF 7/19/10	TOTAL FORECASTED SPENDING 7/20/10	FISCAL YEAR 2011/2012	FISCAL YEAR 2012/2013	FISCAL YEAR 2013/2014	FISCAL YEAR 2014/2015	FISCAL YEAR 2015/2016	OUT YEARS
BUS ENGINEERING													
FARE COLLECTION STUDY	--	1	NR	NYS DOT	\$84,000	\$0	\$84,000	\$0	\$0	\$0	\$0	\$0	\$0
				NFTA	\$31,000	\$0	\$31,000	\$0	\$0	\$0	\$0	\$0	\$0
				TOTAL	\$115,000	\$0	\$115,000	\$0	\$0	\$0	\$0	\$0	\$0
FARE COLLECTION REPLACEMENT	--	7	NR	FTA	\$6,400,000	\$0	\$0	\$0	\$440,000	\$2,980,000	\$2,980,000	\$0	\$0
				NYS DOT	\$800,000	\$0	\$0	\$0	\$55,000	\$372,500	\$372,500	\$0	\$0
				NFTA	\$800,000	\$0	\$0	\$0	\$55,000	\$372,500	\$372,500	\$0	\$0
				TOTAL	\$8,000,000	\$0	\$0	\$0	\$550,000	\$3,725,000	\$3,725,000	\$0	\$0
BUSWASH REPLACEMENT - FRONTIER	--	11	NR	FTA	\$524,952	\$0	\$0	\$0	\$0	\$57,602	\$467,350	\$0	\$0
				NYS DOT	\$65,619	\$0	\$0	\$0	\$0	\$7,200	\$58,419	\$0	\$0
				NFTA	\$65,619	\$0	\$0	\$0	\$0	\$7,200	\$58,419	\$0	\$0
				TOTAL	\$656,190	\$0	\$0	\$0	\$0	\$72,002	\$584,188	\$0	\$0
REPLACEMENT LIFTS - CSBG (6)	--	9	NR	FTA	\$1,482,286	\$0	\$0	\$0	\$0	\$99,843	\$1,382,443	\$0	\$0
				NYS DOT	\$185,286	\$0	\$0	\$0	\$0	\$12,480	\$172,805	\$0	\$0
				NFTA	\$185,286	\$0	\$0	\$0	\$0	\$12,480	\$172,805	\$0	\$0
				TOTAL	\$1,852,858	\$0	\$0	\$0	\$0	\$124,804	\$1,728,054	\$0	\$0
DOOR REPLACEMENT - ALL GARAGES	--	5	SG	FTA	\$403,642	\$0	\$0	\$0	\$48,926	\$354,715	\$0	\$0	\$0
				NYS DOT	\$50,455	\$0	\$0	\$0	\$6,116	\$44,339	\$0	\$0	\$0
				NFTA	\$50,455	\$0	\$0	\$0	\$6,116	\$44,339	\$0	\$0	\$0
				TOTAL	\$504,552	\$0	\$0	\$0	\$61,158	\$443,394	\$0	\$0	\$0
ADA UPGRADES/INTERIOR REHAB.	--	6	NR	FTA	\$279,025	\$0	\$0	\$0	\$36,930	\$242,095	\$0	\$0	\$0
ALL GARAGES				NYS DOT	\$34,878	\$0	\$0	\$0	\$4,616	\$30,262	\$0	\$0	\$0
				NFTA	\$34,878	\$0	\$0	\$0	\$4,616	\$30,262	\$0	\$0	\$0
				TOTAL	\$348,781	\$0	\$0	\$0	\$46,162	\$302,619	\$0	\$0	\$0
CONCRETE/MASONRY WALL REHAB.	--	8	SG	FTA	\$270,343	\$0	\$0	\$0	\$0	\$34,937	\$235,406	\$0	\$0
ALL GARAGES				NYS DOT	\$33,793	\$0	\$0	\$0	\$0	\$4,367	\$29,426	\$0	\$0
				NFTA	\$33,793	\$0	\$0	\$0	\$0	\$4,367	\$29,426	\$0	\$0
				TOTAL	\$337,929	\$0	\$0	\$0	\$0	\$43,671	\$294,258	\$0	\$0

BUS ENGINEERING

PROJECT TITLE	PROJECT NUMBER	PRTY CL	JUST. CL	FUND SOURCE	TOTAL PROJECT BUDGET	PROJECT LIFE ACTUAL AS OF 7/19/10	TOTAL FORECASTED SPENDING 7/20/10	FISCAL YEAR 2011/2012	FISCAL YEAR 2012/2013	FISCAL YEAR 2013/2014	FISCAL YEAR 2014/2015	FISCAL YEAR 2015/2016	OUT YEARS
BABCOCK FUELING ISLAND CANOPY	--	12	NI	FTA	\$66,430	\$0	\$0	\$0	\$0	\$8,672	\$57,758	\$0	\$0
				NYSDOT	\$8,304	\$0	\$0	\$0	\$0	\$1,084	\$7,220	\$0	\$0
				NFTA	\$8,304	\$0	\$0	\$0	\$0	\$1,084	\$7,220	\$0	\$0
				TOTAL	\$83,038	\$0	\$0	\$0	\$0	\$10,840	\$72,198	\$0	\$0
REPLACE HVAC & MAU - BABCOCK & FRONTIER	--	4	NI	FTA	\$783,421	\$0	\$0	\$75,815	\$707,606	\$0	\$0	\$0	\$0
				NYSDOT	\$97,928	\$0	\$0	\$9,477	\$88,451	\$0	\$0	\$0	\$0
				NFTA	\$97,928	\$0	\$0	\$9,477	\$88,451	\$0	\$0	\$0	\$0
				TOTAL	\$979,276	\$0	\$0	\$94,769	\$884,507	\$0	\$0	\$0	\$0
HRV & HV UNIT REPLACEMENT - FRONTIER	--	3	NI	FTA	\$636,343	\$0	\$0	\$67,572	\$568,771	\$0	\$0	\$0	\$0
				NYSDOT	\$79,543	\$0	\$0	\$8,447	\$71,096	\$0	\$0	\$0	\$0
				NFTA	\$79,543	\$0	\$0	\$8,447	\$71,096	\$0	\$0	\$0	\$0
				TOTAL	\$795,429	\$0	\$0	\$84,465	\$710,964	\$0	\$0	\$0	\$0
MAIN SWITCHBOARD CONDITION STUDY	--	2	NR	FTA	\$46,768	\$0	\$0	\$46,768	\$0	\$0	\$0	\$0	\$0
ALL GARAGES				NYSDOT	\$5,846	\$0	\$0	\$5,846	\$0	\$0	\$0	\$0	\$0
				NFTA	\$5,846	\$0	\$0	\$5,846	\$0	\$0	\$0	\$0	\$0
				TOTAL	\$58,460	\$0	\$0	\$58,460	\$0	\$0	\$0	\$0	\$0
PARK LOT LIGHT. CONDUIT & FEEDER REPLACE	2-3360		M	FTA	\$99,040	\$14,321	\$84,719	\$0	\$0	\$0	\$0	\$0	\$0
FRONTIER				NYSDOT	\$12,380	\$1,790	\$10,590	\$0	\$0	\$0	\$0	\$0	\$0
				NFTA	\$12,380	\$1,790	\$10,590	\$0	\$0	\$0	\$0	\$0	\$0
				TOTAL	\$123,800	\$17,901	\$105,899	\$0	\$0	\$0	\$0	\$0	\$0
EMERGENCY POWER FEEDER TO BAY 2	--		SG	FTA	\$117,862	\$0	\$0	\$0	\$0	\$0	\$17,721	\$100,141	\$0
FRONTIER				NYSDOT	\$14,733	\$0	\$0	\$0	\$0	\$0	\$2,215	\$12,518	\$0
				NFTA	\$14,733	\$0	\$0	\$0	\$0	\$0	\$2,215	\$12,518	\$0
				TOTAL	\$147,327	\$0	\$0	\$0	\$0	\$0	\$22,151	\$125,176	\$0
ASPHALT PAVT. REHAB. BABCOCK, FRONTIER, ANDREWS & SENECA CITY LINE LOOP	--		NR	FTA	\$1,033,800	\$0	\$0	\$0	\$0	\$71,269	\$962,331	\$0	\$0
				NYSDOT	\$129,200	\$0	\$0	\$0	\$0	\$8,909	\$120,291	\$0	\$0
				NFTA	\$129,200	\$0	\$0	\$0	\$0	\$8,909	\$120,291	\$0	\$0
				TOTAL	\$1,292,000	\$0	\$0	\$0	\$0	\$89,086	\$1,202,914	\$0	\$0
FACILITY CONDITION & ASSESSMENT STUDY - ALL GARAGES	--		NI	FTA	\$63,000	\$0	\$0	\$0	\$0	\$63,000	\$0	\$0	\$0
				NYSDOT	\$7,875	\$0	\$0	\$0	\$0	\$7,875	\$0	\$0	\$0
				NFTA	\$7,875	\$0	\$0	\$0	\$0	\$7,875	\$0	\$0	\$0
				TOTAL	\$78,750	\$0	\$0	\$0	\$0	\$78,750	\$0	\$0	\$0

FY 2011 / 2012 THROUGH 2015 / 2016

CAPITAL PROJECTS

BUS ENGINEERING

PROJECT TITLE	PROJECT NUMBER	PRTY CL	JUST. CL	FUND SOURCE	TOTAL PROJECT BUDGET	PROJECT LIFE ACTUAL AS OF 7/19/10	TOTAL FORECASTED SPENDING 7/20/10	FISCAL YEAR 2011/2012	FISCAL YEAR 2012/2013	FISCAL YEAR 2013/2014	FISCAL YEAR 2014/2015	FISCAL YEAR 2015/2016	OUT YEARS
REPLACE 800MHZ EDACS RADIO SYSTEM	--			NI FTA	\$4,000,000	\$0	\$0	\$0	\$0	\$0	\$4,000,000	\$0	\$0
				NYSDOT	\$500,000	\$0	\$0	\$0	\$0	\$0	\$500,000	\$0	\$0
				NFTA	\$500,000	\$0	\$0	\$0	\$0	\$0	\$500,000	\$0	\$0
				TOTAL	\$5,000,000	\$0	\$0	\$0	\$0	\$0	\$5,000,000	\$0	\$0
BABCOCK - FIRE WATER BOOSTER PUMP	--	15		NI FTA	\$432,100	\$0	\$0	\$0	\$0	\$0	\$0	\$49,940	\$382,160
				NYSDOT	\$54,013	\$0	\$0	\$0	\$0	\$0	\$0	\$6,243	\$47,770
				NFTA	\$54,013	\$0	\$0	\$0	\$0	\$0	\$0	\$6,243	\$47,770
				TOTAL	\$540,125	\$0	\$0	\$0	\$0	\$0	\$0	\$62,425	\$477,700
COLD SPRING - FIRE WATER BOOSTER PUMP	--	16		NI FTA	\$440,798	\$0	\$0	\$0	\$0	\$0	\$0	\$50,669	\$390,129
				NYSDOT	\$55,100	\$0	\$0	\$0	\$0	\$0	\$0	\$6,334	\$48,766
				NFTA	\$55,100	\$0	\$0	\$0	\$0	\$0	\$0	\$6,334	\$48,766
				TOTAL	\$550,997	\$0	\$0	\$0	\$0	\$0	\$0	\$63,336	\$487,661
FRONTIER - FIRE WATER BOOSTER PUMP	--	17		NI FTA	\$432,100	\$0	\$0	\$0	\$0	\$0	\$0	\$49,940	\$382,160
				NYSDOT	\$54,013	\$0	\$0	\$0	\$0	\$0	\$0	\$6,243	\$47,770
				NFTA	\$54,013	\$0	\$0	\$0	\$0	\$0	\$0	\$6,243	\$47,770
				TOTAL	\$540,125	\$0	\$0	\$0	\$0	\$0	\$0	\$62,425	\$477,700
FRONTIER - SPRINKLER SYSTEM UPGRADES	--	18		NI FTA	\$450,159	\$0	\$0	\$0	\$0	\$0	\$0	\$51,730	\$398,430
				NYSDOT	\$56,270	\$0	\$0	\$0	\$0	\$0	\$0	\$6,466	\$49,804
				NFTA	\$56,270	\$0	\$0	\$0	\$0	\$0	\$0	\$6,466	\$49,804
				TOTAL	\$562,699	\$0	\$0	\$0	\$0	\$0	\$0	\$64,662	\$498,037

FTA	\$17,961,869	\$14,321	\$84,719	\$190,155	\$1,802,233	\$3,912,133	\$10,103,010	\$302,419	\$1,552,878
NYSDOT	\$2,329,234	\$1,790	\$94,590	\$23,769	\$225,279	\$489,017	\$1,262,876	\$37,802	\$194,110
NFTA	\$2,276,234	\$1,790	\$41,590	\$23,769	\$225,279	\$489,017	\$1,262,876	\$37,802	\$194,110
TOTAL	\$22,567,336	\$17,901	\$220,899	\$237,694	\$2,252,791	\$4,890,166	\$12,628,763	\$378,024	\$1,941,098

METRO EXECUTIVE/METRO LINK

PROJECT TITLE	PROJECT NUMBER	PRTY CL	JUST. CL	FUND SOURCE	TOTAL PROJECT BUDGET	PROJECT LIFE ACTUAL AS OF 7/19/10	TOTAL FORECASTED SPENDING 7/20/10	FISCAL YEAR 2011/2012	FISCAL YEAR 2012/2013	FISCAL YEAR 2013/2014	FISCAL YEAR 2014/2015	FISCAL YEAR 2015/2016	OUT YEARS
METRO EXECUTIVE													
OCC REPLACEMENT B/W COPIER	--			FTA	\$8,000	\$0	\$0	\$0	\$8,000	\$0	\$0	\$0	\$0
				NYSDOT	\$1,000	\$0	\$0	\$0	\$1,000	\$0	\$0	\$0	\$0
				NFTA	\$1,000	\$0	\$0	\$0	\$1,000	\$0	\$0	\$0	\$0
				TOTAL	\$10,000	\$0	\$0	\$0	\$10,000	\$0	\$0	\$0	\$0
ERIE CO. SERVICE RESTRUCTURING STUDY	2-3354			NYSDOT	\$716,000	\$541,142	\$174,858	\$0	\$0	\$0	\$0	\$0	\$0
				NFTA	\$179,000	\$135,285	\$43,715	\$0	\$0	\$0	\$0	\$0	\$0
				TOTAL	\$895,000	\$676,427	\$218,573	\$0	\$0	\$0	\$0	\$0	\$0
METRO COMPREHENSIVE TRAINING PROG. FYE 10	2-3357			FTA	\$448,956	\$43,382	\$45,574	\$60,000	\$60,000	\$60,000	\$60,000	\$60,000	\$60,000
FYE 09	2-3341			NYSDOT	\$56,120	\$5,423	\$5,697	\$7,500	\$7,500	\$7,500	\$7,500	\$7,500	\$7,500
				NFTA	\$58,120	\$5,423	\$5,697	\$7,500	\$7,500	\$7,500	\$7,500	\$7,500	\$7,500
				TOTAL	\$561,195	\$54,227	\$56,968	\$75,000	\$75,000	\$75,000	\$75,000	\$75,000	\$75,000
SPECIAL SERVICES - PARATRANSIT													
BUS LINE REAL TIME NEXT BUS IVR MODULE	--			FTA	\$222,883	\$0	\$0	\$222,883	\$0	\$0	\$0	\$0	\$0
				NYSDOT	\$27,860	\$0	\$0	\$27,860	\$0	\$0	\$0	\$0	\$0
				NFTA	\$27,860	\$0	\$0	\$27,860	\$0	\$0	\$0	\$0	\$0
				TOTAL	\$278,604	\$0	\$0	\$278,604	\$0	\$0	\$0	\$0	\$0
REPLACEMENT BUS SHELTERS	2-1030			FTA	\$316,940	\$132,006	\$96,000	\$88,934	\$0	\$0	\$0	\$0	\$0
	2-3359			NYSDOT	\$39,618	\$16,501	\$12,000	\$11,117	\$0	\$0	\$0	\$0	\$0
	2-3375			NFTA	\$39,618	\$16,501	\$12,000	\$11,117	\$0	\$0	\$0	\$0	\$0
	2-3385			TOTAL	\$396,175	\$165,007	\$120,000	\$111,168	\$0	\$0	\$0	\$0	\$0

FTA	\$996,779	\$175,387	\$141,574	\$371,818	\$68,000	\$60,000	\$60,000	\$60,000	\$60,000	\$60,000
NYSDOT	\$840,597	\$563,065	\$192,555	\$46,477	\$8,500	\$7,500	\$7,500	\$7,500	\$7,500	\$7,500
NFTA	\$303,597	\$157,209	\$61,411	\$46,477	\$8,500	\$7,500	\$7,500	\$7,500	\$7,500	\$7,500
TOTAL	\$2,140,974	\$895,661	\$395,541	\$464,772	\$85,000	\$75,000	\$75,000	\$75,000	\$75,000	\$75,000

METRO RAIL- RAIL MAINTENANCE

PROJECT TITLE	PROJECT NUMBER	PRTY CL	JUST. CL	FUND SOURCE	TOTAL PROJECT BUDGET	PROJECT LIFE ACTUAL AS OF 7/19/10	TOTAL FORECASTED SPENDING 7/20/10	FISCAL YEAR 2011/2012	FISCAL YEAR 2012/2013	FISCAL YEAR 2013/2014	FISCAL YEAR 2014/2015	FISCAL YEAR 2015/2016	OUT YEARS
RAIL MAINTENANCE													
MANDATORY													
HALON REHAB/RAIL FACILITIES		3	M	88C	\$60,000	\$0	\$0	\$30,000	\$30,000	\$0	\$0	\$0	\$0
MALL TRACK SWITCHES		5	M	88C	\$320,000	\$0	\$0	\$80,000	\$80,000	\$80,000	\$80,000	\$0	\$0
RAIL FASTENER CLIPS	2-9489	1	M	88C	\$96,000	\$0	\$15,000	\$15,000	\$15,000	\$15,000	\$18,000	\$18,000	\$0
TACTILE STRIPS STATIONS (ADA)	2-9492	4	M	FTA	\$56,000	\$0	\$56,000	\$0	\$0	\$0	\$0	\$0	\$0
				NYS DOT	\$7,000	\$0	\$7,000	\$0	\$0	\$0	\$0	\$0	\$0
				88C	\$82,000	\$0	\$7,000	\$75,000	\$0	\$0	\$0	\$0	\$0
				TOTAL	\$145,000	\$0	\$70,000	\$75,000	\$0	\$0	\$0	\$0	\$0
TC VITAL RELAY REHAB.	2-9477	2	M	88C	\$370,000	\$0	\$25,000	\$60,000	\$65,000	\$70,000	\$75,000	\$75,000	\$0
STATE OF GOOD REPAIR													
BATTERY CHARGER REBUILD - COMO	--	12	SR	88C	\$30,000	\$0	\$0	\$0	\$15,000	\$15,000	\$0	\$0	\$0
BLUE LIGHT FIXTURES	2-9685	22	SR	88C	\$22,422	\$14,422	\$0	\$0	\$4,000	\$4,000	\$0	\$0	\$0
COMMO/FARE REPLACEMENT PARTS (Multi year)	--	18	SR	88C	\$117,000	\$0	\$0	\$0	\$20,000	\$20,000	\$25,000	\$25,000	\$27,000
ELECTRIC PARTS AND BREAKERS - (Multi year)	--	7	SR	88C	\$385,000	\$0	\$0	\$0	\$70,000	\$75,000	\$80,000	\$80,000	\$80,000
EXTERIOR WALL REHAB.	--	28	SR	88C	\$110,000	\$0	\$0	\$0	\$25,000	\$25,000	\$25,000	\$35,000	\$0
FBK BREAKER BOXES	--	27	SR	88C	\$60,000	\$0	\$0	\$0	\$20,000	\$20,000	\$20,000	\$0	\$0
LOW VOLTAGE CONTROLS FOR STATION LIGHTING	--		SR	88C	\$20,000	\$0	\$0	\$0	\$10,000	\$10,000	\$0	\$0	\$0
OVERHEAD DOOR Y&S ALL	--	17	SR	88C	\$80,000	\$0	\$0	\$0	\$30,000	\$30,000	\$0	\$0	\$0
PUMP RE-BUILD PROGRAM	--	13	SR	88C	\$115,000	\$0	\$0	\$0	\$20,000	\$20,000	\$20,000	\$25,000	\$30,000
RAIL EQUIPMENT SRVR UPGRADES (REAL-TIME SYS)	--	19	SR	88C	\$50,000	\$0	\$0	\$0	\$10,000	\$10,000	\$10,000	\$10,000	\$10,000
RAIL MAINTENANCE EQUIPMENT FUND (MULTI-YR)	2-9482	6	SR	88C	\$649,000	\$0	\$25,000	\$0	\$145,000	\$15,000	\$152,000	\$155,000	\$157,000
SONNET REPLACEMENT CIRCUIT BOARDS	--	11	SR	88C	\$20,000	\$0	\$0	\$0	\$10,000	\$10,000	\$0	\$0	\$0
STATION LOUVERS REHAB. SYSTEM WIDE	--	20	SR	88C	\$45,000	\$0	\$0	\$0	\$15,000	\$15,000	\$15,000	\$0	\$0
TRACK SWITCH PARTS AND HARDWARE	--	15	SR	88C	\$130,000	\$0	\$0	\$0	\$30,000	\$30,000	\$35,000	\$35,000	\$0
TRACTION POWER MANHOLE DOSSERT REPLACE.	--	24	SR	88C	\$40,000	\$0	\$0	\$0	\$10,000	\$10,000	\$10,000	\$10,000	\$0
TRAIN CONTROL & WAYSIDE COMPONONETS (Multi year)	--	8	SR	88C	\$180,000	\$0	\$0	\$0	\$30,000	\$35,000	\$35,000	\$40,000	\$40,000
NORMAL REPLACEMENT													
RM84 PAYLOADER REPLACEMENT	--		NR	88C	\$150,000	\$0	\$0	\$0	\$150,000	\$0	\$0	\$0	\$0
RM1165 BOBCAT REPLACEMENT	--	16	NR	88C	\$26,000	\$0	\$0	\$0	\$26,000	\$0	\$0	\$0	\$0
EDAC MONITORS	--	20	NR	88C	\$25,000	\$0	\$0	\$0	\$25,000	\$0	\$0	\$0	\$0
COMO BATTERY REPLACEMENT 12 VOLTS (F.A.) RADIO	--		NR	88C	\$0								
DUMP TRUCK WITH PLOW REPLACEMENT	--	10	NR	88C	\$295,000	\$0	\$0	\$0	\$145,000	\$0	\$150,000	\$0	\$0
(9) FLOOR AUTO SCRUBBERS	--		NR	88C	\$80,000	\$0	\$0	\$0	\$80,000	\$0	\$0	\$0	\$0
INTERIOR LIFT REPLACEMENT	--		NR	88C	\$28,000	\$0	\$0	\$0	\$28,000	\$0	\$0	\$0	\$0
PICKUP TRUCK REPLACEMENT	--	14	NR	88C	\$70,000	\$0	\$0	\$0	\$35,000	\$0	\$35,000	\$0	\$0
OFFICE WINDOWS Y&S	--		NR	88C	\$120,000	\$0	\$0	\$0	\$120,000	\$0	\$0	\$0	\$0
TUNNEL FLUSHING TRUCK - REPLACEMENT	--	9	NR	88C	\$450,000	\$0	\$0	\$0	\$450,000	\$0	\$0	\$0	\$0
YARD TRACK SWITCH MACHINE REPLACEMENT	--		NR	88C	\$60,000	\$0	\$0	\$0	\$0	\$30,000	\$0	\$30,000	\$0
YARD & SURFACE TRK SW HEATERS REPLACE.	--		NR	88C	\$135,000	\$0	\$0	\$0	\$30,000	\$35,000	\$35,000	\$35,000	\$0

METRO RAIL- RAIL MAINTENANCE

PROJECT TITLE	PROJECT NUMBER	PRTY CL	JUST. CL	FUND SOURCE	TOTAL PROJECT BUDGET	PROJECT LIFE	TOTAL	FISCAL	FISCAL	FISCAL	FISCAL	FISCAL	OUT YEARS
						ACTUAL AS OF 7/19/10	FORECASTED SPENDING 7/20/10	YEAR 2011/2012	YEAR 2012/2013	YEAR 2013/2014	YEAR 2014/2015	YEAR 2015/2016	
NEW INITIATIVES													
23 KV PT TRUCK	--		NI	88C	\$75,000	\$0	\$0	\$0	\$75,000	\$0	\$0	\$0	\$0
EXTERIOR ARTICULATING LIFT	--		NI	88C	\$70,000	\$0	\$0	\$0	\$0	\$0	\$70,000	\$0	\$0
GLASS BLOCK WINDOWS DL&W	--		NI	88C	\$160,000	\$0	\$0	\$0	\$80,000	\$80,000	\$0	\$0	\$0
STREET SWEEPER	--		NI	88C	\$160,000	\$0	\$0	\$0	\$0	\$0	\$0	\$160,000	\$0
WALK OFF GRATES	--	10	NI	88C	\$80,000	\$0	\$0	\$0	\$40,000	\$40,000	\$0	\$0	\$0
NEW PROJECTS													
CALL DETAILER RECORDER	--		NI	88C	\$100,000	\$0	\$0	\$0	\$0	\$0	\$100,000	\$0	\$0
CAMERAS FOR PARK & RIDE LOTS	--	21	NI	88C	\$30,000	\$0	\$0	\$0	\$15,000	\$15,000	\$0	\$0	\$0
MOVE YARD PRINGLE SWITCHS DOWN	--		NI	88C	\$15,000	\$0	\$0	\$0	\$15,000	\$0	\$0	\$0	\$0
NEW LIGHTS ESCALATOR TUBES	--	23	NI	88C	\$5,000	\$0	\$0	\$0	\$5,000	\$0	\$0	\$0	\$0
PACE & ETS SOFTWARE UPGRADE	--		NI	88C	\$90,000	\$0	\$0	\$0	\$0	\$90,000	\$0	\$0	\$0
ADDITIONAL MAINT. STORAGE AT STATION	--		NI	88C	\$80,000	\$0	\$0	\$0	\$0	\$0	\$0	\$80,000	\$0
BLAST PROOF GARBAGE CANS	--		NI	88C	\$25,000	\$0	\$0	\$0	\$25,000	\$0	\$0	\$0	\$0
CATENARY POLES & CROSSARM REHAB.	--		NI	88C	\$100,000	\$0	\$0	\$0	\$0	\$50,000	\$50,000	\$0	\$0
CATENARY TESIONER REPLACEMENT	--		NI	88C	\$50,000	\$0	\$0	\$0	\$50,000	\$0	\$0	\$0	\$0
CONCRETE UNDER TRAIN SHED	--		NI	88C	\$120,000	\$0	\$0	\$0	\$0	\$120,000	\$0	\$0	\$0
EMERGENCY PANEL REHAB.	--		NI	88C	\$30,000	\$0	\$0	\$0	\$30,000	\$0	\$0	\$0	\$0
ESCALATORS BILCO DOOR REPLACEMENT.	--		NI	88C	\$125,000	\$0	\$0	\$0	\$0	\$0	\$0	\$0	\$125,000
EXIT LIGHT REPLACEMENT	--		NI	88C	\$15,000	\$0	\$0	\$0	\$15,000	\$0	\$0	\$0	\$0
EXTERIOR DOOR AT ALLEN MEDICAL STATION	--		NI	88C	\$100,000	\$0	\$0	\$0	\$0	\$100,000	\$0	\$0	\$0
HALON ACTUATOR PANELS UPGRADE	--		NI	88C	\$100,000	\$0	\$0	\$0	\$0	\$50,000	\$50,000	\$0	\$0
HIGH SPEED DC TRIP BOXES (DC BRK)	--		NI	88C	\$60,000	\$0	\$0	\$0	\$20,000	\$20,000	\$20,000	\$0	\$0
IMPEDANCE BONDS FOR TRAIN CONTROL	--		NI	88C	\$50,000	\$0	\$0	\$0	\$25,000	\$25,000	\$0	\$0	\$0
LAWNMOWERS	--		NI	88C	\$20,000	\$0	\$0	\$0	\$20,000	\$0	\$0	\$0	\$0
LOCAL CONTROL PANELS (DC SUBS)	--		NI	88C	\$70,000	\$0	\$0	\$0	\$0	\$0	\$70,000	\$0	\$0
METRO VISION IN EACH STATION	--		NI	88C	\$50,000	\$0	\$0	\$0	\$0	\$50,000	\$0	\$0	\$0
NEW LIGHTS IN ROCK TUNNEL LIGHT TRAYS	--		NI	88C	\$100,000	\$0	\$0	\$0	\$100,000	\$0	\$0	\$0	\$0
PELCO CAMERA REPLACEMENT	--		NI	88C	\$100,000	\$0	\$0	\$0	\$0	\$0	\$100,000	\$0	\$0
RAIL STOREROOM 2ND FLOOR	--		NI	88C	\$60,000	\$0	\$0	\$0	\$0	\$60,000	\$0	\$0	\$0
REBUILD ALL CROSS DRAINS ON RIGHT OF WAY	--		NI	88C	\$100,000	\$0	\$0	\$0	\$50,000	\$50,000	\$0	\$0	\$0
REFURBISH RIVERWALK RAILING	--		NI	88C	\$75,000	\$0	\$0	\$0	\$75,000	\$0	\$0	\$0	\$0
SHOP BOILER REHAB. (RETUBE)	--		NI	88C	\$20,000	\$0	\$0	\$0	\$0	\$20,000	\$0	\$0	\$0
SNOWBLOWERS	--		NI	88C	\$20,000	\$0	\$0	\$0	\$0	\$0	\$0	\$20,000	\$0
SPARE RAIL	--		NI	88C	\$100,000	\$0	\$0	\$0	\$0	\$50,000	\$50,000	\$0	\$0
STATION FLOOR TILES REHAB.	--		NI	88C	\$20,000	\$0	\$0	\$0	\$0	\$20,000	\$0	\$0	\$0
STATION INFORMATION PANELS	--		NI	88C	\$100,000	\$0	\$0	\$0	\$0	\$0	\$100,000	\$0	\$0
STATION RESTROOM REHAB.	--		NI	88C	\$100,000	\$0	\$0	\$0	\$0	\$0	\$0	\$0	\$100,000
SURFACE STATION REHAB.	--		NI	88C	\$100,000	\$0	\$0	\$0	\$25,000	\$25,000	\$25,000	\$25,000	\$0
TRACK SWITCH HEATERS	--		NI	88C	\$100,000	\$0	\$0	\$0	\$30,000	\$30,000	\$40,000	\$0	\$0

FY 2011 / 2012 THROUGH 2015 / 2016

CAPITAL PROJECTS

METRO RAIL- RAIL MAINTENANCE

PROJECT TITLE	PROJECT NUMBER	PRTY CL	JUST. CL	FUND SOURCE	TOTAL PROJECT BUDGET	PROJECT LIFE	TOTAL	FISCAL	FISCAL	FISCAL	FISCAL	FISCAL	OUT YEARS
						ACTUAL AS OF 7/19/10	FORECASTED SPENDING 7/20/10	YEAR 2011/2012	YEAR 2012/2013	YEAR 2013/2014	YEAR 2014/2015	YEAR 2015/2016	
VENT SHAFT LIGHTING REPLACEMENT	--		NI	88C	\$20,000	\$0	\$0	\$0	\$0	\$0	\$20,000	\$0	\$0
800 MHZ RADIO REPLACEMENT	--		NI	88C	\$2,000,000	\$0	\$0	\$0	\$0	\$0	\$0	\$0	\$2,000,000
ASBESTOS REMOVAL VENT SHAFTS	--		NI	88C	\$1,000,000	\$0	\$0	\$0	\$500,000	\$500,000	\$0	\$0	\$0
CATENARY AND INSULATORS REPLACEMENT	--		NI	88C	\$2,000,000	\$0	\$0	\$0	\$1,000,000	\$1,000,000	\$0	\$0	\$0
ELEVATORS REPLACEMENT	--		NI	88C	\$14,000,000	\$0	\$0	\$0	\$0	\$0	\$0	\$0	\$14,000,000
ESCALATORS REPLACEMENT	--		NI	88C	\$15,000,000	\$0	\$0	\$0	\$0	\$0	\$0	\$0	\$15,000,000
EXHAUST FAN REPLACEMENT	--		NI	88C	\$250,000	\$0	\$0	\$0	\$0	\$250,000	\$0	\$0	\$0
F/C TVM UPGRADE	--		NI	88C	\$500,000	\$0	\$0	\$0	\$0	\$0	\$0	\$0	\$500,000
MALL SWITCHES (RR)	--		NI	88C	\$320,000	\$0	\$0	\$0	\$80,000	\$80,000	\$80,000	\$80,000	\$0
PAYLOADER REPLACEMENT	--		NI	88C	\$150,000	\$0	\$0	\$0	\$150,000	\$0	\$0	\$0	\$0
REPLACE WINDOWS W/ GLASS BLOCKS	--		NI	88C	\$160,000	\$0	\$0	\$0	\$80,000	\$80,000	\$0	\$0	\$0
REPLACE YARD SWITCHES (R.R.) (EAST)	--		NI	88C	\$130,000	\$0	\$0	\$0	\$40,000	\$45,000	\$0	\$45,000	\$0
SPECIAL TRACKWORK REPLACEMENT	--		NI	88C	\$4,000,000	\$0	\$0	\$0	\$0	\$0	\$2,000,000	\$2,000,000	\$0
STATION HVAC DUCT WORK REHAB.	--		NI	88C	\$300,000	\$0	\$0	\$0	\$0	\$0	\$0	\$300,000	\$0
SAMPLE STATION PANEL LINERS	--		NI	88C	\$30,000	\$0	\$0	\$0	\$30,000	\$0	\$0	\$0	\$0
TUNNEL REHAB.	--		NI	88C	\$1,000,000	\$0	\$0	\$0	\$0	\$250,000	\$250,000	\$250,000	\$250,000
UPS REPLACEMENT	--		NI	88C	\$3,000,000	\$0	\$0	\$0	\$0	\$0	\$0	\$0	\$3,000,000

FTA	\$56,000	\$0	\$56,000	\$0	\$0	\$0	\$0	\$0	\$0	\$0	\$0
NYS DOT	\$7,000	\$0	\$7,000	\$0	\$0	\$0	\$0	\$0	\$0	\$0	\$0
88C	\$51,035,422	\$14,422	\$72,000	\$260,000	\$4,318,000	\$3,674,000	\$3,845,000	\$3,533,000	\$35,319,000		
TOTAL	\$51,098,422	\$14,422	\$135,000	\$260,000	\$4,318,000	\$3,674,000	\$3,845,000	\$3,533,000	\$35,319,000		

CAPITAL PROJECTS

METRO RAIL RAILCAR

PROJECT TITLE	PROJECT NUMBER	PRTY CL	JUST. CL	FUND SOURCE	TOTAL PROJECT BUDGET	PROJECT LIFE ACTUAL AS OF 7/19/10	TOTAL FORECASTED SPENDING 7/20/10	FISCAL YEAR 2011/2012	FISCAL YEAR 2012/2013	FISCAL YEAR 2013/2014	FISCAL YEAR 2014/2015	FISCAL YEAR 2015/2016	OUT YEARS
RAILCAR													
LRV REPLACE BRAKE PARTS/EQUIPMENT	2-9487	1	M	88C	\$304,000	\$0	\$50,000	\$50,000	\$50,000	\$50,000	\$52,000	\$52,000	\$0
BRAKE ROTOR HUBS	--	9	SR	88C	\$120,000	\$0	\$0	\$120,000	\$0	\$0	\$0	\$0	\$0
LRV AIR SYSTEMS VALVES	--		SR	88C	\$50,000	\$0	\$0	\$0	\$0	\$50,000	\$0	\$0	\$0
LRV COMPRESSOR OVERHAUL	--	6	SR	88C	\$69,000	\$0	\$0	\$24,000	\$0	\$45,000	\$0	\$0	\$0
LRV EQUIPMENT FUND	--	2	SR	88C	\$335,000	\$0	\$0	\$62,000	\$65,000	\$68,000	\$70,000	\$70,000	\$0
LRV GEAR UNIT PARTS	2-9485	5	SR	88C	\$167,000	\$0	\$15,000	\$50,000	\$0	\$50,000	\$0	\$52,000	\$0
LRV HS CIRCUIT BREAKERS	--	7	SR	88C	\$90,000	\$0	\$0	\$40,000	\$0	\$0	\$50,000	\$0	\$0
LRV WHEEL REPLACEMENT/PARTS	--		SR	88C	\$140,000	\$0	\$0	\$0	\$140,000	\$0	\$0	\$0	\$0
UPGRADE WHEEL TRUING MACHINE	--	11	SR	88C	\$650,000	\$0	\$0	\$0	\$650,000	\$0	\$0	\$0	\$0
LRV TRACTION MOTOR OVERHAUL	2-9488	4	NR	88C	\$240,000	\$0	\$12,000	\$42,000	\$44,000	\$45,000	\$47,000	\$50,000	\$0
LRV BRAKE SHOES	2-9486	8	NR	88C	\$80,000	\$0	\$25,000	\$0	\$25,000	\$0	\$30,000	\$0	\$0
LRV REPLACE PANTOGRAPHS/EQUIP.	--		NR	88C	\$125,000	\$0	\$0	\$0	\$0	\$125,000	\$0	\$0	\$0
LRV VEHICLES DECALS	--		NR	88C	\$15,000	\$0	\$0	\$0	\$0	\$0	\$0	\$15,000	\$0
PANTOGRAPH SHOES	--	3	NR	88C	\$90,000	\$0	\$0	\$30,000	\$0	\$30,000	\$0	\$30,000	\$0
NEW PROJECTS													
VIDEO SURVALENCE UPGRADE	--	10	NI	88C	\$300,000	\$0	\$0	\$0	\$300,000	\$0	\$0	\$0	\$0

88C \$2,775,000 \$0 \$102,000 \$418,000 \$1,274,000 \$463,000 \$249,000 \$269,000 \$0

METRO RAIL - ENGINEERING

PROJECT TITLE	PROJECT NUMBER	PRTY CL	JUST. CL	FUND SOURCE	TOTAL PROJECT BUDGET	PROJECT LIFE ACTUAL AS OF 7/19/10	TOTAL FORECASTED SPENDING 7/20/10	FISCAL YEAR 2011/2012	FISCAL YEAR 2012/2013	FISCAL YEAR 2013/2014	FISCAL YEAR 2014/2015	FISCAL YEAR 2015/2016	OUT YEARS
METRO RAIL - ENGINEERING													
STATE OF GOOD REPAIR													
LRV MID-LIFE REBUILD	2-9773	M	SR	FTA	\$20,273,623	\$7,037,486	\$4,276,997	\$4,230,000	\$4,230,000	\$499,140	\$0	\$0	\$0
				NYS DOT	\$2,535,235	\$882,126	\$534,170	\$528,300	\$528,300	\$62,339	\$0	\$0	\$0
				NYS DTF	\$14,527,182	\$2,907,544	\$3,754,657	\$3,713,400	\$3,713,400	\$438,181	\$0	\$0	\$0
				88-C	\$2,535,235	\$882,126	\$534,170	\$528,300	\$528,300	\$62,339	\$0	\$0	\$0
				INSURANCE	\$784,725	\$0	\$784,725	\$0	\$0	\$0	\$0	\$0	\$0
				PRIVATE	\$128,725	\$128,725	\$0	\$0	\$0	\$0	\$0	\$0	\$0
				TOTAL	\$40,784,726	\$11,838,007	\$9,884,719	\$9,000,000	\$9,000,000	\$1,062,000	\$0	\$0	\$0
LRV TRAIN CONTROL CARBORNE ATP SYSTEM	2-9475	M	SR	FTA	\$3,005,124	\$25,872	\$118,903	\$1,430,174	\$1,430,174	\$0	\$0	\$0	\$0
				NYS DOT	\$375,641	\$3,234	\$14,863	\$178,772	\$178,772	\$0	\$0	\$0	\$0
				88-C	\$375,641	\$3,234	\$14,863	\$178,772	\$178,772	\$0	\$0	\$0	\$0
				TOTAL	\$3,756,405	\$32,340	\$148,629	\$1,787,718	\$1,787,718	\$0	\$0	\$0	\$0
VENTILATION DAMPER REPLACEMENT - PHASE III	--		SR	FTA	\$3,347,945	\$0	\$0	\$0	\$0	\$0	\$224,134	\$3,123,811	\$0
				NYS DOT	\$418,493	\$0	\$0	\$0	\$0	\$0	\$28,017	\$390,476	\$0
				88-C	\$418,493	\$0	\$0	\$0	\$0	\$0	\$28,017	\$390,476	\$0
				TOTAL	\$4,184,931	\$0	\$0	\$0	\$0	\$0	\$280,167	\$3,904,764	\$0
PLATFORM CONDUIT AND PANEL REHAB.	--		SR	88-C	\$2,456,795	\$0	\$0	\$0	\$170,831	\$2,285,964	\$0	\$0	\$0
FDSI FOR LRRT STATIONS	2-9474	M	SR	FTA	\$1,455,196	\$31,002	\$199,398	\$1,024,000	\$200,796	\$0	\$0	\$0	\$0
				NYS DOT	\$181,900	\$3,875	\$24,925	\$128,000	\$25,100	\$0	\$0	\$0	\$0
				88-C	\$181,900	\$3,875	\$24,925	\$128,000	\$25,100	\$0	\$0	\$0	\$0
				TOTAL	\$1,818,995	\$38,753	\$249,247	\$1,280,000	\$250,995	\$0	\$0	\$0	\$0
FASTENER & PAD REPLACE. - PHASE 6	2-9493	M	SR	FTA	\$205,595	\$0	\$20,000	\$185,595	\$0	\$0	\$0	\$0	\$0
				88-C	\$73,815	\$0	\$68,000	\$5,815	\$0	\$0	\$0	\$0	\$0
				TOTAL	\$279,410	\$0	\$88,000	\$191,410	\$0	\$0	\$0	\$0	\$0
FASTENER & PAD REPLACE. - PHASE 7	--	1	SR	FTA	\$772,056	\$0	\$0	\$772,056	\$0	\$0	\$0	\$0	\$0
				NYS DOT	\$96,507	\$0	\$0	\$96,507	\$0	\$0	\$0	\$0	\$0
				88-C	\$96,507	\$0	\$0	\$96,507	\$0	\$0	\$0	\$0	\$0
				TOTAL	\$965,070	\$0	\$0	\$965,070	\$0	\$0	\$0	\$0	\$0
FASTENER & PAD REPLACE. - PHASE 8	--	2	SR	FTA	\$2,387,907	\$0	\$0	\$0	\$2,387,907	\$0	\$0	\$0	\$0
				NYS DOT	\$298,488	\$0	\$0	\$0	\$298,488	\$0	\$0	\$0	\$0
				88-C	\$298,488	\$0	\$0	\$0	\$298,488	\$0	\$0	\$0	\$0
				TOTAL	\$2,984,884	\$0	\$0	\$0	\$2,984,884	\$0	\$0	\$0	\$0

METRO RAIL - ENGINEERING

PROJECT TITLE	PROJECT NUMBER	PRTY CL	JUST. CL	FUND SOURCE	TOTAL PROJECT BUDGET	PROJECT LIFE ACTUAL AS OF 7/19/10	TOTAL FORECASTED SPENDING 7/20/10	FISCAL YEAR 2011/2012	FISCAL YEAR 2012/2013	FISCAL YEAR 2013/2014	FISCAL YEAR 2014/2015	FISCAL YEAR 2015/2016	OUT YEARS
FASTENER & PAD REPLACE. - PHASE 9	--	3	SR	FTA	\$2,739,600	\$0	\$0	\$0	\$0	\$2,739,600	\$0	\$0	\$0
				NYSDOT	\$342,450	\$0	\$0	\$0	\$0	\$342,450	\$0	\$0	\$0
				88-C	\$342,450	\$0	\$0	\$0	\$0	\$342,450	\$0	\$0	\$0
				TOTAL	\$3,424,500	\$0	\$0	\$0	\$0	\$3,424,500	\$0	\$0	\$0
LASALLE BUS LOOP REPLACEMENT	--		SR	88-C	\$665,634	\$0	\$0	\$0	\$0	\$0	\$98,398	\$567,236	\$0
REHAB/WIDEN UTICA BUS LOOP & REPL. ENTRANCE STEPS	--		SR	88-C	\$457,087	\$0	\$0	\$0	\$0	\$0	\$53,380	\$403,707	\$0
WIDEN UNIVERSITY BUS LOOP	--		SR	FTA	\$340,342	\$0	\$0	\$0	\$0	\$41,327	\$299,014	\$0	\$0
				NYSDOT	\$42,543	\$0	\$0	\$0	\$0	\$5,166	\$37,377	\$0	\$0
				88-C	\$42,543	\$0	\$0	\$0	\$0	\$5,166	\$37,377	\$0	\$0
				TOTAL	\$425,427	\$0	\$0	\$0	\$0	\$51,659	\$373,768	\$0	\$0
STATION PANEL LINER REHAB - PHASE I	--		SR	88-C	\$2,183,496	\$0	\$0	\$0	\$0	\$309,246	\$1,874,250	\$0	\$0
STATION PANEL LINER REHAB - PHASE II	--		SR	88-C	\$771,750	\$0	\$0	\$0	\$0	\$0	\$110,250	\$661,500	\$0
STATION PANEL LINER REHAB - PHASE III	--		SR	88-C	\$826,875	\$0	\$0	\$0	\$0	\$0	\$0	\$124,031	\$702,844
STATION PANEL LINER REHAB - PHASE IV	--		SR	88-C	\$10,363,500	\$0	\$0	\$0	\$0	\$0	\$0	\$0	\$10,363,500
NORMAL REPLACEMENT													
TRAIN CONTROL AND SCADA REPLACE. PH I (SERVERS)	2-9483	M	NR	FTA	\$233,516	\$567	\$232,949	\$0	\$0	\$0	\$0	\$0	\$0
				NYSDOT	\$29,190	\$71	\$29,119	\$0	\$0	\$0	\$0	\$0	\$0
				88C	\$29,190	\$71	\$29,119	\$0	\$0	\$0	\$0	\$0	\$0
				TOTAL	\$291,895	\$709	\$291,186	\$0	\$0	\$0	\$0	\$0	\$0
TRAIN CONTROL AND SCADA REPLACEMENT PH II	--		NR	88-C	\$6,109,556	\$0	\$0	\$0	\$0	\$0	\$1,215,451	\$4,894,105	\$0
RAIL FARE COLLECTION REPLACEMENT	--		NR	FTA	\$4,000,000	\$0	\$0	\$0	\$0	\$0	\$4,000,000	\$0	\$0
				NYSDOT	\$500,000	\$0	\$0	\$0	\$0	\$0	\$500,000	\$0	\$0
				88-C	\$500,000	\$0	\$0	\$0	\$0	\$0	\$500,000	\$0	\$0
				TOTAL	\$5,000,000	\$0	\$0	\$0	\$0	\$0	\$5,000,000	\$0	\$0
LANDSCAPING IMPROVEMENTS @ HUMBOLDT & DELEVAN	--		NR	FTA	\$80,406	\$0	\$0	\$0	\$0	\$0	\$0	\$0	\$80,406
				NYSDOT	\$10,051	\$0	\$0	\$0	\$0	\$0	\$0	\$0	\$10,051
				88-C	\$10,051	\$0	\$0	\$0	\$0	\$0	\$0	\$0	\$10,051
				TOTAL	\$100,507	\$0	\$0	\$0	\$0	\$0	\$0	\$0	\$100,507
SYSTEMWIDE STATION PA REPLACEMENT	--		NR	88-C	\$1,568,881	\$0	\$0	\$0	\$0	\$109,595	\$1,459,286	\$0	\$0
SYSTEMWIDE EXTERIOR LIGHT POLE REPLACEMENTS	--		NR	88-C	\$1,987,642	\$0	\$0	\$0	\$0	\$126,181	\$1,861,461	\$0	\$0
ARTWORK REHAB	--		NR	88-C	\$97,240	\$0	\$0	\$0	\$0	\$0	\$0	\$0	\$97,240
CONTROLLER'S CONSOLE REPLACEMENT @ OCC	--		NR	88-C	\$722,358	\$0	\$0	\$0	\$0	\$0	\$0	\$108,817	\$613,541
LASALLE/HUMBOLDT/UTICA/ SUMMER-BEST ROOF REPLACE	--		NR	88-C	\$792,973	\$0	\$0	\$0	\$0	\$0	\$0	\$119,235	\$673,738
Y & S LOTS REPLACEMENT	--		NR	88-C	\$115,650	\$0	\$0	\$0	\$0	\$0	\$0	\$17,252	\$98,398
PARK & RIDE LOTS REPLACEMENT	--		NR	88-C	\$648,270	\$0	\$0	\$0	\$0	\$0	\$0	\$98,398	\$549,872
ACOUSTICAL INSULATION REPLACEMENTS	--		NR	88-C	\$474,047	\$0	\$0	\$0	\$0	\$0	\$0	\$0	\$474,047
ELEVATOR/ESCALATOR CATHODIC PROTECTION TEST	--		NR	88-C	\$119,587	\$0	\$0	\$0	\$119,587	\$0	\$0	\$0	\$0

METRO RAIL - ENGINEERING

PROJECT TITLE	PROJECT NUMBER	PRTY CL	JUST. CL	FUND SOURCE	TOTAL PROJECT BUDGET	PROJECT LIFE	TOTAL	FISCAL	FISCAL	FISCAL	FISCAL	FISCAL	OUT YEARS
						ACTUAL AS OF 7/19/10	FORECASTED SPENDING 7/20/10	YEAR 2011/2012	YEAR 2012/2013	YEAR 2013/2014	YEAR 2014/2015	YEAR 2015/2016	
NEW INITIATIVE													
UNIVERSITY STATION NEW ESCALATOR	--		NI	FTA	\$719,601	\$0	\$0	\$0	\$0	\$0	\$62,161	\$657,440	\$0
				NYS DOT	\$89,950	\$0	\$0	\$0	\$0	\$0	\$7,770	\$82,180	\$0
				88-C	\$89,950	\$0	\$0	\$0	\$0	\$0	\$7,770	\$82,180	\$0
				TOTAL	\$899,501	\$0	\$0	\$0	\$0	\$0	\$77,701	\$821,800	\$0
FINAL DESIGN/CONSTRUCT - TRAFFIC ON MAIN ST. *													
	--	M	NI	FHWA	\$60,566,940	\$0	\$0	\$0	\$14,771,295	\$39,868,605	\$5,927,040	\$0	\$0
				NYS DOT	\$11,356,301	\$0	\$0	\$0	\$2,769,618	\$7,475,363	\$1,111,320	\$0	\$0
				COB	\$2,551,869	\$0	\$0	\$0	\$627,780	\$1,694,416	\$229,673	\$0	\$0
				88-C	\$1,233,565	\$0	\$0	\$0	\$295,426	\$797,372	\$140,767	\$0	\$0
				TOTAL	\$75,708,675	\$0	\$0	\$0	\$18,464,119	\$49,835,756	\$7,408,800	\$0	\$0
PUBLIC INFO. / SCHEDULING DISPLAY - PHASE III	--		NI	88-C	\$2,266,496	\$0	\$0	\$0	\$0	\$156,138	\$2,110,358	\$0	\$0
TUNNEL LIGHT ENERGY CONSERVATION	--		NI	ESCO	\$486,202	\$0	\$0	\$0	\$0	\$0	\$0	\$0	\$486,202

* Assumptions:

NFTA & COB split of local share remains to be negotiated.

2012/2013 work includes both north and south end of Main Street.

Work at south end of Main Street assumes traffic sharing the track bed.

FTA	\$39,560,910	\$7,094,928	\$4,848,247	\$7,641,825	\$8,248,878	\$3,280,067	\$4,585,309	\$3,781,251	\$80,406
NYS DOT	\$16,276,748	\$889,306	\$603,076	\$931,579	\$3,800,278	\$7,885,319	\$1,684,484	\$472,656	\$10,051
NYS DTF	\$14,527,182	\$2,907,544	\$3,754,657	\$3,713,400	\$3,713,400	\$438,181	\$0	\$0	\$0
88-C	\$38,855,664	\$889,306	\$671,076	\$937,394	\$1,616,504	\$4,194,451	\$9,496,765	\$7,466,937	\$13,583,231
FHWA	\$60,566,940	\$0	\$0	\$0	\$14,771,295	\$39,868,605	\$5,927,040	\$0	\$0
COB	\$2,551,869	\$0	\$0	\$0	\$627,780	\$1,694,416	\$229,673	\$0	\$0
ESCO	\$486,202	\$0	\$0	\$0	\$0	\$0	\$0	\$0	\$486,202
INSURANCE	\$784,725	\$0	\$784,725	\$0	\$0	\$0	\$0	\$0	\$0
PRIVATE	\$128,725	\$128,725	\$0	\$0	\$0	\$0	\$0	\$0	\$0
TOTAL	\$173,738,965	\$11,909,809	\$10,661,781	\$13,224,198	\$32,778,134	\$57,361,039	\$21,923,270	\$11,720,845	\$14,159,889

TRANSPORTATION CENTERS

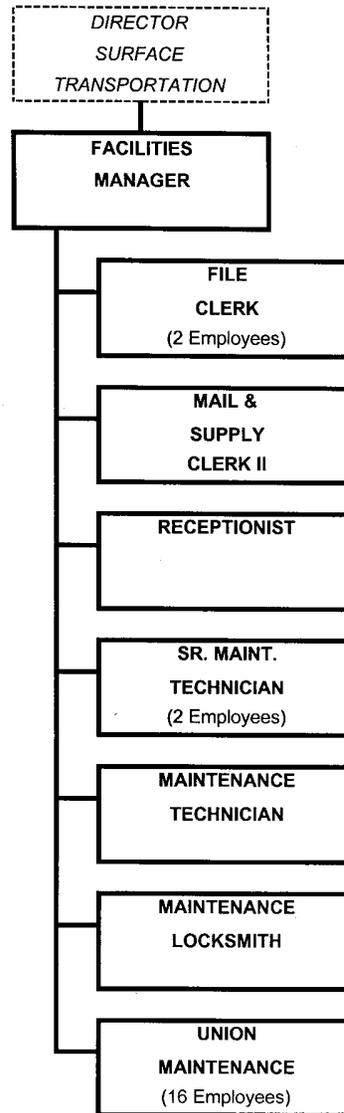

TOTAL EMPLOYEES 25

TRANSPORTATION CENTERS

2010/11 ANNUAL BUDGET

VS

2011/12 ANNUAL BUDGET

	FY 09-10 ACTUAL	FY 10-11 BUDGET	FY 11-12 BUDGET	VARIANCE	%
OPERATING REVENUES					
Rental Income	1,608,275	1,793,000	1,705,388	-87,612	-4.9%
Concessions/Commissions	71,756	41,500	67,730	26,230	63.2%
Retail Sales	0	0	0	0	n/a
Resales & Rebillings	4,500	4,500	4,500	0	0.0%
Other Operating Revenues	0	0	0	0	n/a
TOTAL OPERATING REVENUES	1,684,531	1,839,000	1,777,618	-61,382	-3.3%
OPERATING EXPENSES (Excl. Depr.)					
Personnel Services	1,301,804	1,474,777	1,403,234	-71,543	-4.9%
Maintenance & Repairs	200,326	197,749	188,170	-9,579	-4.8%
Utilities	446,875	469,209	508,217	39,008	8.3%
Insurance & Injuries	67,524	22,950	25,884	2,934	12.8%
Safety & Security	461,440	513,643	463,953	-49,690	-9.7%
General Business/Other	869,205	928,499	892,900	-35,599	-3.8%
Administrative Cost Reallocation	395,941	412,420	383,771	-28,648	-6.9%
Costs Transferred to Capital Projects	0	0	0	0	n/a
Inter Division Reimbursement	-1,140,545	-1,283,004	-1,186,527	96,477	-7.5%
TOTAL OPERATING EXPENSES	2,602,570	2,736,243	2,679,602	-56,640	-2.1%
OPERATING INCOME/(LOSS)	-918,039	-897,243	-901,984	-4,742	0.5%
NON-OPERATING ITEMS					
Debt Service - Noresco	-63,948	-63,944	-64,037	-93	0.1%
Intercompany Transfer	633,207	779,838	700,000	-79,838	-10.2%
TOTAL NON-OPERATING ITEMS	569,259	715,894	635,963	-79,931	-11.2%
NET INCOME/(LOSS)	-348,780	-181,349	-266,021	-84,673	46.7%
LESS: DIRECT CAPITAL	604,817	494,064	563,040	68,976	14.0%
LESS: INDIRECT CAPITAL	17,651	27,547	39,510	11,963	43.4%
NET SURPLUS/(DEFICIT)	-971,247	-702,959	-868,571	-165,612	23.6%

NIAGARA FRONTIER TRANSPORTATION AUTHORITY
(ACCOUNTCO, ACCOUNTUNIT, ACCOUNT)
BUDGET WORKSHEETS - Fiscal Year 2011-12

Company 1 Niagara Frontier Transportation Authority
Division 05 METRO TRANSPORTATION CENTER
Department 0099 ADMINISTRATIVE AND GENERAL

Account	Description	2009-10 Actual	2010-11 Budget	2010-11 Sept. YTD Actual	2011-12 Req Budget	VARIANCE From Budget
510	EMPLOYEE SALARIES	699,469	748,174	534,543	722,438	25,736-
515	EMPLOYEE BENEFITS	268,402	332,767	244,662	337,950	5,183
520	MAINTENANCE AND REPAIRS	91,446	98,499	74,022	90,600	7,899-
524	AUTOMOTIVE	13,824	7,999	6,813	8,250	251
526	JANITORIAL AND LAUNDRY	50,436	51,500	43,333	47,600	3,900-
530	GROUNDS & LANDSCAPING	1,522	2,000	1,388	1,450	550-
534	TELEPHONE	951	999	486	864	135-
541	INSURANCE	65,747	22,949	16,539	23,847	898
542	CLAIM LOSSES			605	1,000	1,000
551	ARMED GUARDS	461,440	513,643	370,805	463,953	49,690-
571	CONSULTANTS/OUTSIDE SERVICES	45,488	25,000	22,873	26,000	1,000
576	EMPLOYEE TRAVEL	693		450		
578	POSTAGE	47	50	390	200	150
580	GENERAL OFFICE	5,475	3,750	541	4,100	350
592	DIVISION OPERATIONS	68,785-	73,308-	50,925-	68,247-	5,061
TOTAL	EXPENSES	1,636,155	1,734,022	1,266,525	1,660,005	74,017-

05 METRO TRANSPORTATION CENTER
99 ADMINISTRATIVE AND GENERAL

EMPLOYEE GROUP: PB-ALL

Job Description	Grade/Step	Base Salary	Increase Amount	Longevity Amount	Scheduled Amount
FACILITIES MANAGER	14	69,000			69,000
NON-REP Totals	1	69,000			69,000
SR. MAINTENANCE TECH.	8 6	51,118	2,586	1,100	54,804
SR. MAINTENANCE TECH.	8 5	48,325	3,227	500	52,052
MAINT. TECH I	7 5	43,136	4,169		47,305
MAINT LOCKSMITH	7 2	39,149	2,603		41,752
CUSTODIAN	E 6	36,813		1,400	38,213
CUSTODIAN	E 6	36,813		1,400	38,213
CUSTODIAN II	F 6	27,787		900	28,687
CUSTODIAN II	F 6	27,787		900	28,687
CUSTODIAN II	F 6	27,787		700	28,487
CUSTODIAN II	F 6	27,787		700	28,487
CUSTODIAN II	F 6	27,787		700	28,487
CUSTODIAN II	F 6	27,787		700	28,487
CUSTODIAN II	F 6	27,787		700	28,487
CUSTODIAN II	F 6	27,787		700	28,487
CUSTODIAN II	F 6	27,787		700	28,487
CUSTODIAN II	F 6	27,787		700	28,487
CUSTODIAN II	F 6	26,629	1,158		27,787
CUSTODIAN II	F 6	27,787			27,787
CUSTODIAN II	F 5	25,523	1,106		26,629
UNION Totals	17	557,589	14,849	9,700	582,138
Department Totals	18	626,589	14,849	9,700	651,138

NIAGARA FRONTIER TRANSPORTATION AUTHORITY
(ACCOUNTCO, ACCOUNTUNIT, ACCOUNT)
BUDGET WORKSHEETS - Fiscal Year 2011-12

Company 1 Niagara Frontier Transportation Authority
Division 05 METRO TRANSPORTATION CENTER
Department 0519 BUS DOCK AREA

Account	Description	2009-10 Actual	2010-11 Budget	2010-11 Sept. YTD Actual	2011-12 Req Budget	VARIANCE From Budget
431	BUILDING SPACE	20,544-	17,000-	16,302-	21,795-	4,795-
	TOTAL REVENUES	20,544-	17,000-	16,302-	21,795-	4,795-

NIAGARA FRONTIER TRANSPORTATION AUTHORITY
(ACCOUNTCO, ACCOUNTUNIT, ACCOUNT)
BUDGET WORKSHEETS - Fiscal Year 2011-12

Company 1 Niagara Frontier Transportation Authority
Division 05 METRO TRANSPORTATION CENTER
Department 0519 BUS DOCK AREA

Account	Description	2009-10 Actual	2010-11 Budget	2010-11 Sept. YTD Actual	2011-12 Req Budget	VARIANCE From Budget
531	ELECTRIC POWER	8,259	8,672	5,355	9,683	1,011
532	GAS	1,135	1,192	345	1,192	
TOTAL	EXPENSES	9,394	9,864	5,700	10,875	1,011

NIAGARA FRONTIER TRANSPORTATION AUTHORITY
(ACCOUNTCO, ACCOUNTUNIT, ACCOUNT)
BUDGET WORKSHEETS - Fiscal Year 2011-12

Company 1 Niagara Frontier Transportation Authority
Division 05 METRO TRANSPORTATION CENTER
Department 0529 BUS TERMINAL EXCLUSIVE AREA

Account	Description	2009-10 Actual	2010-11 Budget	2010-11 Sept. YTD Actual	2011-12 Req Budget	VARIANCE From Budget
431	BUILDING SPACE	439,029-	490,000-	336,565-	465,766-	24,234
441	CONCESSIONS	152-				
462	REBILLINGS	4,500-	4,500-	3,649-	4,500-	
TOTAL REVENUES		443,681-	494,500-	340,214-	470,266-	24,234

NIAGARA FRONTIER TRANSPORTATION AUTHORITY
(ACCOUNTCO, ACCOUNTUNIT, ACCOUNT)
BUDGET WORKSHEETS - Fiscal Year 2011-12

Company 1 Niagara Frontier Transportation Authority
Division 05 METRO TRANSPORTATION CENTER
Department 0529 BUS TERMINAL EXCLUSIVE AREA

Account	Description	2009-10 Actual	2010-11 Budget	2010-11 Sept. YTD Actual	2011-12 Req Budget	VARIANCE From Budget
531	ELECTRIC POWER	129,797	136,287	45,498	117,745	18,542-
532	GAS	7,180	7,539	2,186	7,539	
533	WATER	179	188	155	213	25
TOTAL EXPENSES		137,156	144,014	47,839	125,497	18,517-

NIAGARA FRONTIER TRANSPORTATION AUTHORITY
(ACCOUNTCO, ACCOUNTUNIT, ACCOUNT)
BUDGET WORKSHEETS - Fiscal Year 2011-12

Company 1 Niagara Frontier Transportation Authority
Division 05 METRO TRANSPORTATION CENTER
Department 0539 MTC - BUS TERMINAL PUBLIC AREA

Account	Description	2009-10 Actual	2010-11 Budget	2010-11 Sept. YTD Actual	2011-12 Req Budget	VARIANCE From Budget
431	BUILDING SPACE	34,944-	38,500-	26,208-	37,000-	1,500
441	CONCESSIONS	65,057-	36,000-	48,716-	62,250-	26,250-
442	COMMISSIONS	6,467-	5,500-	3,685-	5,400-	100
	TOTAL REVENUES	106,468-	80,000-	78,609-	104,650-	24,650-

NIAGARA FRONTIER TRANSPORTATION AUTHORITY
(ACCOUNTCO, ACCOUNTUNIT, ACCOUNT)
BUDGET WORKSHEETS - Fiscal Year 2011-12

Company 1 Niagara Frontier Transportation Authority
Division 05 METRO TRANSPORTATION CENTER
Department 0539 MTC - BUS TERMINAL PUBLIC AREA

Account	Description	2009-10 Actual	2010-11 Budget	2010-11 Sept. YTD Actual	2011-12 Req Budget	VARIANCE From Budget
531	ELECTRIC POWER	87,754	92,141	114,094	117,847	25,706
532	GAS	15,165	15,923	4,617	14,879	1,044-
TOTAL EXPENSES		102,919	108,064	118,711	132,726	24,662

NIAGARA FRONTIER TRANSPORTATION AUTHORITY
(ACCOUNTCO, ACCOUNTUNIT, ACCOUNT)
BUDGET WORKSHEETS - Fiscal Year 2011-12

Company 1 Niagara Frontier Transportation Authority
Division 05 METRO TRANSPORTATION CENTER
Department 0549 OFFICE TOWER AREA

Account	Description	2009-10 Actual	2010-11 Budget	2010-11 Sept. YTD Actual	2011-12 Req Budget	VARIANCE From Budget
432	ALLOCATED OFFICE EXP	1,113,757-	1,247,500-	756,624-	1,180,827-	66,673
	TOTAL REVENUES	1,113,757-	1,247,500-	756,624-	1,180,827-	66,673

NIAGARA FRONTIER TRANSPORTATION AUTHORITY
(ACCOUNTCO, ACCOUNTUNIT, ACCOUNT)
BUDGET WORKSHEETS - Fiscal Year 2011-12

Company 1 Niagara Frontier Transportation Authority
Division 05 METRO TRANSPORTATION CENTER
Department 0549 OFFICE TOWER AREA

Account	Description	2009-10 Actual	2010-11 Budget	2010-11 Sept. YTD Actual	2011-12 Req Budget	VARIANCE From Budget
531	ELECTRIC POWER	72,696	76,331	94,618	92,668	16,337
532	GAS	12,459	13,081	3,793	13,082	1
533	WATER	10,686	11,220	7,716	10,092	1,128-
TOTAL EXPENSES		95,841	100,632	106,127	115,842	15,210

NIAGARA FRONTIER TRANSPORTATION AUTHORITY
(ACCOUNTCO, ACCOUNTUNIT, ACCOUNT)
BUDGET WORKSHEETS - Fiscal Year 2011-12

Company 1 Niagara Frontier Transportation Authority
Division 05 METRO TRANSPORTATION CENTER
Department 0575 CENTRAL SERVICES

Account	Description	2009-10 Actual	2010-11 Budget	2010-11 Sept. YTD Actual	2011-12 Req Budget	VARIANCE From Budget
510	EMPLOYEE SALARIES	157,467	188,809	126,414	146,161	42,648-
515	EMPLOYEE BENEFITS	60,916	86,227	58,981	69,757	16,470-
524	AUTOMOTIVE	4,041	1,250	1,077	2,920	1,670
526	JANITORIAL AND LAUNDRY	4,575	4,999	2,383	3,500	1,499-
531	ELECTRIC POWER	5,189	5,448	3,869	5,781	333
532	GAS	4,005	4,204	2,017	4,205	1
533	WATER	80	83	62	89	6
534	TELEPHONE	20,926	21,972	15,791	25,730	3,758
541	INSURANCE	37		22	37	37
572	RENT EXPENSE	794,075	875,500	523,479	842,400	33,100-
578	POSTAGE	15,392	16,199	5,434	12,700	3,499-
580	GENERAL OFFICE	5,050	5,000	6,754	5,000	
592	DIVISION OPERATIONS	1,071,764-	1,209,695-	748,734-	1,118,280-	91,415
TOTAL	EXPENSES	11-	4-	2,451-		4

QB201 Date 03/24/11
Time 08:34

Niagara Frontier Transportation Authority
Print Personnel Budget Worksheets 2010 - 2011

Page 15

05 METRO TRANSPORTATION CENTER
0575 CENTRAL SERVICES

EMPLOYEE GROUP: PB-ALL

Job Description	Grade/Step		Base Salary	Increase Amount	Longevity Amount	Scheduled Amount
-----	-----	-----	-----	-----	-----	-----
FILE CLERK IV	4	6	37,299	1,887	650	39,836
MAIL & SUPPLY CLERK II	3	6	34,575	1,749	650	36,974
FILE CLERK II	2	6	31,046	2,419		33,465
RECEPTIONIST	2	2	26,886	1,680		28,566
UNION Totals	4		129,806	7,735	1,300	138,841
Department Totals	4		129,806	7,735	1,300	138,841

NIAGARA FRONTIER TRANSPORTATION AUTHORITY
(ACCOUNTCO, ACCOUNTUNIT, ACCOUNT)
BUDGET WORKSHEETS - Fiscal Year 2011-12

Company 1 Niagara Frontier Transportation Authority
Division 05 METRO TRANSPORTATION CENTER
Department 0579 MECHANICAL EQUIPMENT AREA

Account	Description	2009-10 Actual	2010-11 Budget	2010-11 Sept. YTD Actual	2011-12 Req Budget	VARIANCE From Budget
531	ELECTRIC POWER	7,524	7,899	9,783	9,582	1,683
532	GAS	1,284	1,347	391	1,348	1
TOTAL EXPENSES		8,808	9,246	10,174	10,930	1,684

QB204 Date 03/23/11
Time 14:17

NIAGARA FRONTIER TRANSPORTATION AUTHORITY
(ACCOUNTCO, ACCOUNTUNIT, ACCOUNT)
BUDGET WORKSHEETS - Fiscal Year 2011-12

Page 47
CREDITS = (-)
DEBITS = (+)

Company 1 Niagara Frontier Transportation Authority
Division 07 NIAG. FALLS INTL. TRANS. CENTR
Department 0099 ADMINISTRATIVE AND GENERAL

Account	Description	2009-10 Actual	2010-11 Budget	2010-11 Sept. YTD Actual	2011-12 Req Budget	VARIANCE From Budget
441	CONCESSIONS	78-		82-	80-	80-
	TOTAL REVENUES	78-		82-	80-	80-

NIAGARA FRONTIER TRANSPORTATION AUTHORITY
(ACCOUNTCO, ACCOUNTUNIT, ACCOUNT)
BUDGET WORKSHEETS - Fiscal Year 2011-12

Company 1 Niagara Frontier Transportation Authority
Division 07 NIAG. FALLS INTL. TRANS. CENTR
Department 0099 ADMINISTRATIVE AND GENERAL

Account	Description	2009-10 Actual	2010-11 Budget	2010-11 Sept. YTD Actual	2011-12 Req Budget	VARIANCE From Budget
510	EMPLOYEE SALARIES	83,149	82,660	61,255	87,517	4,857
515	EMPLOYEE BENEFITS	32,386	36,137	27,964	39,411	3,274
520	MAINTENANCE AND REPAIRS	12,014	13,500	13,679	13,500	
524	AUTOMOTIVE	3,770	1,500	815	3,000	1,500
526	JANITORIAL AND LAUNDRY	16,887	14,499	5,954	15,350	851
530	GROUNDS & LANDSCAPING	1,807	2,000	2,095	2,000	
531	ELECTRIC POWER	28,555	29,983	23,987	34,058	4,075
532	GAS	3,983	4,182	1,180	4,182	
533	WATER	3,208	3,368	3,662	3,676	308
534	TELEPHONE	25,854	27,147	18,013	33,762	6,615
542	CLAIM LOSSES	1,739			1,000	1,000
580	GENERAL OFFICE	2,983	3,000	2,237	2,500	500-
TOTAL	EXPENSES	216,335	217,976	160,841	239,956	21,980

QB201 Date 03/24/11
Time 08:34

Niagara Frontier Transportation Authority
Print Personnel Budget Worksheets 2010 - 2011

07 NIAG. FALLS INTL. TRANS. CENTR
99 ADMINISTRATIVE AND GENERAL

EMPLOYEE GROUP: PB-ALL

Job Description	Grade/Step	Base Salary	Increase Amount	Longevity Amount	Scheduled Amount
CUSTODIAN II	F 5	25,523	1,106		26,629
CUSTODIAN II	F 4	24,469	1,054		25,523
CUSTODIAN II	F 3	23,465	1,004		24,469
UNION Totals	3	73,457	3,164		76,621
Department Totals	3	73,457	3,164		76,621

NIAGARA FRONTIER TRANSPORTATION AUTHORITY
(ACCOUNTCO, ACCOUNTUNIT, ACCOUNT)
BUDGET WORKSHEETS - Fiscal Year 2011-12

Company 2 NFT Metro System, Inc.
Division 40 METRO TRANS. AND MAINTENANCE
Department 4056 OPERATIONS CONTROL CENTER

Account	Description	2009-10 Actual	2010-11 Budget	2010-11 Sept. YTD Actual	2011-12 Req Budget	VARIANCE From Budget
523	IMPROVEMENTS & REPLACEMENTS	8,101				
531	ELECTRIC POWER	129,061	135,514	114,192	158,980	23,466
533	WATER	3,619	3,800	2,431	3,593	207-
571	CONSULTANTS/OUTSIDE SERVICES	50,853	52,046	50,814	52,545	499
TOTAL EXPENSES		191,634	191,360	167,437	215,118	23,758

METROPOLITAN TRANSPORTATION CENTER

PROJECT TITLE	PROJECT NUMBER	PRTY CL	JUST. CL	FUND SOURCE	TOTAL PROJECT BUDGET	PROJECT LIFE ACTUAL AS OF 7/19/10	TOTAL FORECASTED SPENDING 7/20/10	FISCAL YEAR 2011/2012	FISCAL YEAR 2012/2013	FISCAL YEAR 2013/2014	FISCAL YEAR 2014/2015	FISCAL YEAR 2015/2016	OUT YEARS
MTC													
REPLACE TOWER WINDOWS - 2012	--		SG	NFTA	\$31,256	\$0	\$0	\$0	\$31,256	\$0	\$0	\$0	\$0
REPLACE JOHN DEER TRACTOR	--		NR	NFTA	\$35,000	\$0	\$0	\$0	\$0	\$35,000	\$0	\$0	\$0
MTC - AHU 3 & 4 REPLACEMENT	--		NR	NFTA	\$1,328,915	\$0	\$0	\$89,908	\$1,239,007	\$0	\$0	\$0	\$0
MTC - CONCOURSE RESTROOM REHAB.	--		NR	NFTA	\$876,990	\$0	\$0	\$0	\$88,389	\$788,601			
REPLACE FLOOR SCRUBBER	--		NR	NFTA	\$15,000	\$0	\$0	\$15,000	\$0	\$0	\$0	\$0	\$0
EAGLE ALLEY REHAB.	--		SG	NFTA	\$78,020	\$0	\$0	\$0	\$0	\$16,282	\$61,738	\$0	\$0
CONCRETE SIDEWALK & CURB REPLACE.	--		NR	NFTA	\$180,990	\$0	\$0	\$0	\$30,544	\$150,446	\$0	\$0	\$0
CONCOURSE LEVEL MODIFICATIONS	--		SG	FUTURE FUNDING	\$21,635,686	\$0		\$1,494,444	\$20,141,242	\$0	\$0	\$0	\$0
MTC POOL CARS	--		NR	NFTA	\$50,000	\$0	\$0	\$0	\$50,000	\$0	\$0	\$0	\$0
MTC PLOW TRUCK	2-0589		NR	NFTA	\$37,000	\$0	\$37,000	\$0	\$0	\$0	\$0	\$0	\$0
OCC													
CARPET REPLACEMENT	--		NR	88C	\$17,388	\$0	\$0	\$0	\$17,388	\$0	\$0	\$0	\$0
				NFTA	\$30,912	\$0	\$0	\$0	\$30,912	\$0	\$0	\$0	\$0
				TOTAL	\$48,300	\$0	\$0	\$0	\$48,300	\$0	\$0	\$0	\$0
FIRST FLOOR SITUATION ROOM HVAC	--		NI	NYTEC	\$79,447	\$0	\$13,342	\$66,105	\$0	\$0	\$0	\$0	\$0
AHU NO. 2 REPLACEMENT	--		NR	NYTEC	\$132,078	\$0	\$21,987	\$110,091	\$0	\$0	\$0	\$0	\$0
AHU NO. 1 REPLACEMENT	--		NR	NYTEC	\$77,305	\$0	\$0	\$0	\$12,754	\$64,551	\$0	\$0	\$0
				88C	\$27,830	\$0	\$0	\$0	\$4,591	\$23,238	\$0	\$0	\$0
				NFTA	\$49,475	\$0	\$0	\$0	\$8,163	\$41,312	\$0	\$0	\$0
				TOTAL	\$154,609	\$0	\$0	\$0	\$25,508	\$129,101	\$0	\$0	\$0
AUDIOLOGGER REPLACEMENT	--		SR	FTA	\$160,000	\$0	\$0	\$160,000	\$0	\$0	\$0	\$0	\$0
				NYS DOT	\$20,000	\$0	\$0	\$20,000	\$0	\$0	\$0	\$0	\$0
				NFTA	\$20,000	\$0	\$0	\$20,000	\$0	\$0	\$0	\$0	\$0
				TOTAL	\$200,000	\$0	\$0	\$200,000	\$0	\$0	\$0	\$0	\$0

METROPOLITAN TRANSPORTATION CENTER

PROJECT TITLE	PROJECT NUMBER	PRTY CL	JUST. CL	FUND SOURCE	TOTAL PROJECT BUDGET	PROJECT LIFE	TOTAL	FISCAL	FISCAL	FISCAL	FISCAL	FISCAL	OUT YEARS
						ACTUAL AS OF 7/19/10	FORECASTED SPENDING 7/20/10	YEAR 2011/2012	YEAR 2012/2013	YEAR 2013/2014	YEAR 2014/2015	YEAR 2015/2016	
MTC													
1404 MAIN STREET													
1404 MAIN STREET WATERLINE	--		SG	NFTA	\$136,332	\$0	\$0	\$21,190	\$115,142	\$0	\$0	\$0	\$0
NFTC - PORTAGE ROAD													
NFTC NEW FACILITY	CLOSED	2-0715		SEN.	\$0	\$0	\$0	\$0	\$0	\$0	\$0	\$0	\$0
		2-0718		M	NYSDTF	\$0	\$0	\$0	\$0	\$0	\$0	\$0	\$0
				NFTA*	\$9,570,674	\$6,756,317	\$312,705	\$416,942	\$416,942	\$416,942	\$416,942	\$416,942	\$416,942
				METRO CAP RES	\$0	\$0	\$0	\$0	\$0	\$0	\$0	\$0	\$0
				TOTAL	\$9,570,674	\$6,756,317	\$312,705	\$416,942	\$416,942	\$416,942	\$416,942	\$416,942	\$416,942
FIBER OPTIC CONNECTION	2-0723		M	NFTA	\$25,000	\$0	\$25,000	\$0	\$0	\$0	\$0	\$0	\$0

* - Includes \$4.6 million capital and \$6 million in interest.

NFTA	\$12,465,564	\$6,756,317	\$374,705	\$563,040	\$2,010,355	\$1,448,583	\$478,680	\$416,942	\$416,942
FTA	\$160,000	\$0	\$0	\$160,000	\$0	\$0	\$0	\$0	\$0
NYS DOT	\$20,000	\$0	\$0	\$20,000	\$0	\$0	\$0	\$0	\$0
88C	\$45,218	\$0	\$0	\$0	\$21,979	\$23,238	\$0	\$0	\$0
FUTURE FUND.	\$21,635,686	\$0	\$0	\$1,494,444	\$20,141,242	\$0	\$0	\$0	\$0
NYTEC	\$288,830	\$0	\$35,329	\$176,196	\$12,754	\$64,551	\$0	\$0	\$0
TOTAL	\$34,615,297	\$6,756,317	\$410,034	\$2,413,680	\$22,186,330	\$1,536,372	\$478,680	\$416,942	\$416,942

AVIATION BUSINESS GROUP

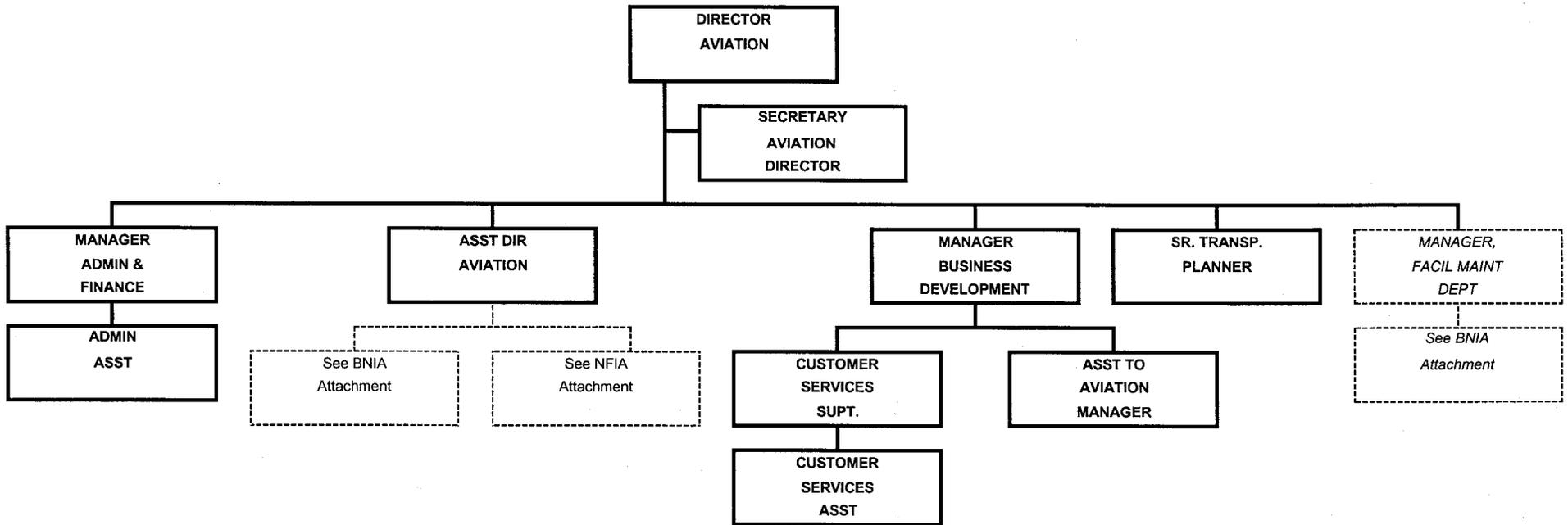

TOTAL EMPLOYEES 10

BUFFALO NIAGARA INTERNATIONAL AIRPORT

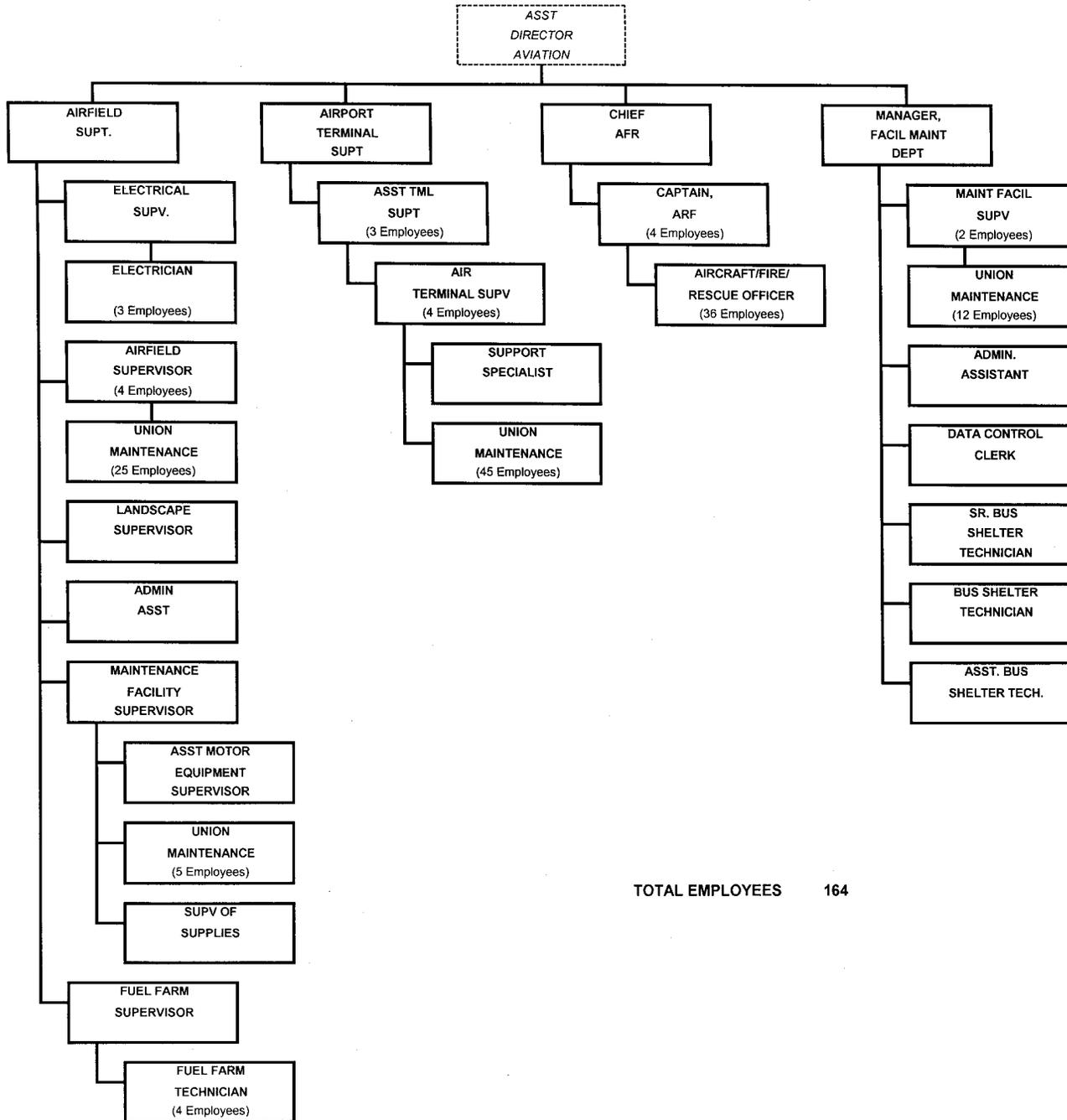

TOTAL EMPLOYEES 164

BNIA
2010/11 ANNUAL BUDGET
VS
2011/12 ANNUAL BUDGET

	FY 09-10 ACTUAL	FY 10-11 BUDGET	FY 11-12 BUDGET	VARIANCE	%
OPERATING REVENUES					
Airport Fees & Services	14,807,375	15,551,922	16,458,636	906,714	5.8%
Rental Income	8,591,663	9,109,343	9,069,111	-40,232	-0.4%
Concessions/Commissions	26,506,052	27,938,065	28,472,979	534,914	1.9%
Resales & Rebillings	1,381,602	1,420,902	1,416,042	-4,860	-0.3%
Other Operating Revenues	<u>2,617,716</u>	<u>2,777,260</u>	<u>3,077,145</u>	<u>299,885</u>	<u>10.8%</u>
TOTAL OPERATING REVENUES	53,904,408	56,797,492	58,493,913	1,696,421	3.0%
OPERATING EXPENSES (Excl. Depr.)					
Personnel Services	11,997,219	12,971,881	13,148,336	176,455	1.4%
Maintenance & Repairs	8,045,835	8,579,708	8,747,324	167,616	2.0%
Utilities	2,284,503	2,427,325	2,675,230	247,905	10.2%
Insurance & Injuries	448,218	479,129	494,366	15,237	3.2%
Safety & Security	5,184,202	5,630,871	5,417,739	-213,132	-3.8%
General Business/Other	5,941,488	6,352,146	6,385,625	33,479	0.5%
Admin Cost Reallocation	2,961,046	3,084,282	2,870,034	-214,248	-6.9%
Costs Transferred to Cap'l Proj	-136,417	-83,106	-91,921	-8,815	10.6%
Inter Division Reimbursement	<u>-1,670,102</u>	<u>-1,825,939</u>	<u>-1,768,642</u>	<u>57,297</u>	<u>-3.1%</u>
TOTAL OPERATING EXPENSES	35,055,992	37,616,297	37,878,091	261,794	0.7%
OPERATING INCOME/(LOSS)	18,848,416	19,181,195	20,615,822	1,434,627	7.5%
NON-OPERATING ITEMS					
Bond Debt Service	-14,432,043	-14,284,239	-14,152,999	131,240	-0.9%
Oper Exp Reserve & R&R Rsv	15,348	-213,227	-294,202	-80,975	38.0%
NFIA Contr (Excluding Debt Svc)	-1,305,510	-1,653,313	-1,670,091	-16,778	1.0%
NFIA Contribution - Debt Service	-539,666	-2,180,160	-2,092,371	87,789	-4.0%
ADF NFIA Debt Service Funding	539,666	1,000,000	1,000,000	0	0.0%
Debt Service - Glycol Collection	-309,168	-305,020	-300,415	4,605	-1.5%
Debt Service - Noresco	-272,999	-272,994	-273,133	-139	0.1%
Interest Income	453,534	375,000	250,000	-125,000	-33.3%
Entitlements	0	0	1,000,000	1,000,000	n/a
PFC	<u>3,475,314</u>	<u>2,691,920</u>	<u>2,691,920</u>	<u>0</u>	<u>0.0%</u>
TOTAL NON-OPERATING ITEMS	-12,375,524	-14,842,033	-13,841,291	1,000,742	-6.7%
NET INCOME/(LOSS)	6,472,892	4,339,162	6,774,531	2,435,369	56.1%
LESS: DIRECT CAPITAL	616,667	73,000	0	-73,000	-100.0%
LESS: INDIRECT CAPITAL	<u>132,000</u>	<u>206,009</u>	<u>295,476</u>	<u>89,466</u>	<u>43.4%</u>
NET SURPLUS/(DEFICIT)	5,724,225	4,060,153	6,479,056	2,418,903	59.6%

BUFFALO NIAGARA INTERNATIONAL AIRPORT

DESCRIPTION

The Buffalo Niagara International Airport (BNIA) is the primary commercial airport for Western New York and Southern Ontario. BNIA provides safe, high quality, and reliable scheduled air passenger and cargo services. The mission of BNIA is to provide quality aviation services and facilities in a manner that enhances customer service and is cost effective.

Eight scheduled air carriers regional/commuter airlines fly out of BNIA handling approximately 5.4 million passengers annually.

The 1,000 acres of airport property includes two runways (8,827 ft. and 7,161 ft. in length), an FAA Air Traffic Control Tower, Flight Service Station, Weather Observatory, Aviation Fuel System, General Aviation Facility, and an Aircraft Rescue and Firefighting facility.

The BNIA terminal and parking facilities are comfortable, easy to use facilities that are equipped with 24 airline gate positions including an international gate as well as 5,000 on-site and 2,300 remote public parking spaces.

Several construction projects have recently been completed which provide patrons with an expanded security screening area, a state of the art baggage handling system, and improved food and concession venues. Additionally, BNIA recently became one of the first airports in the country to use an environmentally friendly glycol treatment system during the winter season.

A state-of-the-art air cargo facility including 1,000,000 square feet of apron area is located on the airport complex. Two scheduled air freight forwarders based at the facility handle the majority of the 70 million pounds of yearly cargo.

Additionally, BNIA has a Facilities Maintenance staff which provides building system support (HVAC, roofing, conveyors, remodeling, etc.) for approximately 21 buildings, 284 bus shelters, and 22 miles of former railroad right of ways within the NFTA and its various business centers.

In addition, BNIA enjoys the reputation of providing exemplary snow removal services known throughout the airline industry.

PROGRAM AND SERVICE OBJECTIVES

- Achieve optimal standards of performance in relation to delivering high quality customer service and satisfaction.
- Operate first class public parking facilities in a manner which makes customer service the hallmark of the operation but still maximizes returns to the Authority.
- Increase the number of passengers utilizing BNIA by aggressively improving service and reducing air fares to several key business markets and maintaining service and low air fares to key leisure markets.
- Maximize BNIA long term parking market share through sales and marketing to major local corporate travelers and contingent market radio advertising campaigns.
- Develop and implement a long-range plan to increase parking capacity to meet increasing demand.
- Implement a long-range plan to maximize usage of the expanded terminal space.
- Support unit and snow equipment replacement program to ensure safe air carrier operations.
- Promote and facilitate a safe working environment for BNIA employees, with an effort toward minimizing employee injuries and reducing workers' compensation expense.

KEY PERFORMANCE INDICATORS

	<u>FYE 10 Actual</u>	<u>FYE 11 Original Budget</u>	<u>FYE 11 Current Estimate</u>	<u>FYE 12 Budget</u>
FAA Regulations	100%	100%	100%	100%
Total Passengers	5,294,915	5,591,428	5,275,166	5,380,670
Air Carrier Flights	74,119	74,119	74,119	74,119
Total Air Freight (lbs) (000's omitted)	71,400	71,400	76,500	76,500
<u>Revenue per passenger:</u>				
Parking lot revenue	\$6.33	\$6.51	\$6.88	\$6.87
Auto rental	\$2.36	\$2.30	\$2.42	\$2.49
Food, beverage & retail	<u>\$.77</u>	<u>\$.74</u>	<u>\$.77</u>	<u>\$.77</u>
Total	\$9.46	\$9.55	\$10.07	\$10.13

NIAGARA FRONTIER TRANSPORTATION AUTHORITY
(ACCOUNTCO, ACCOUNTUNIT, ACCOUNT)
BUDGET WORKSHEETS - Fiscal Year 2011-12

Company 1 Niagara Frontier Transportation Authority
Division 02 BUFFALO NIAGARA INTL. AIRPORT
Department 0099 ADMINISTRATIVE AND GENERAL

Account	Description	2009-10 Actual	2010-11 Budget	2010-11 Sept. YTD Actual	2011-12 Req Budget	VARIANCE From Budget
491	TRAFFIC FINES	27,441-	39,032-	41,549-	47,462-	8,430-
499	OTHER OPERATING REVENUES	7,641-	8,500-	6,337-	8,500-	
	TOTAL REVENUES	35,082-	47,532-	47,886-	55,962-	8,430-

NIAGARA FRONTIER TRANSPORTATION AUTHORITY
(ACCOUNTCO, ACCOUNTUNIT, ACCOUNT)
BUDGET WORKSHEETS - Fiscal Year 2011-12

Company 1 Niagara Frontier Transportation Authority
Division 02 BUFFALO NIAGARA INTL. AIRPORT
Department 0099 ADMINISTRATIVE AND GENERAL

Account	Description	2009-10 Actual	2010-11 Budget	2010-11 Sept. YTD Actual	2011-12 Req Budget	VARIANCE From Budget
510	EMPLOYEE SALARIES	753,784	738,369	525,172	710,599	27,770-
515	EMPLOYEE BENEFITS	285,982	346,889	245,047	357,379	10,490
534	TELEPHONE	17,087	20,908	11,121	19,055	1,853-
571	CONSULTANTS/OUTSIDE SERVICES	11,458	6,030	39,112	62,814	56,784
574	TAXES AND ASSESSMENTS	421,511	464,621	282,562	442,988	21,633-
575	PRINTING & ADVERTISING	83,353	78,999	16,213	88,000	9,001
576	EMPLOYEE TRAVEL	21,430	25,000	20,350	25,000	
577	EMPLOYEE TRAINING	2,269	3,682	3,301	2,269	1,413-
578	POSTAGE	1,893	1,449	919	1,700	251
580	GENERAL OFFICE	75,187	135,875	84,383	108,150	27,725-
584	FREIGHT	17,970	19,000	10,737	19,000	
591	PROJECTS	75,260-	82,076-	49,801-	81,100-	976
592	DIVISION OPERATIONS	12,381-				
TOTAL	EXPENSES	1,604,283	1,758,746	1,189,116	1,755,854	2,892-

02 BUFFALO NIAGARA INTL. AIRPORT
99 ADMINISTRATIVE AND GENERAL

EMPLOYEE GROUP: PB-ALL

Job Description	Grade/Step		Base Salary	Increase Amount	Longevity Amount	Scheduled Amount
DIRECTOR, AVIATION	24		130,133		700	130,833
ASSIST. DIRECTOR OF AV ADMINISTRATION & FINAN	19		90,686			90,686
Mgr. Avia Bus Dev./NFI	18	1	89,587		700	90,287
CUSTOMER SERVICES SUPT	18		87,550			87,550
ASST CUST SVC REP	13	1	67,383		700	68,083
		0	34,500			34,500
NON-REP Totals	6		499,839		2,100	501,939
SR. TRANSPORTATION PLA	13	6	74,620	3,775	1,400	79,795
Asst. to Aviation Mgmt	2	5	55,231	3,081	1,800	60,112
SECRETARY TO DIR. OF A	5	6	40,080	2,027	1,400	43,507
ADMIN ASST	4	6	37,840	792	650	39,282
UNION Totals	4		207,771	9,675	5,250	222,696
Department Totals	10		707,610	9,675	7,350	724,635

NIAGARA FRONTIER TRANSPORTATION AUTHORITY
(ACCOUNTCO, ACCOUNTUNIT, ACCOUNT)
BUDGET WORKSHEETS - Fiscal Year 2011-12

Company 1 Niagara Frontier Transportation Authority
Division 02 BUFFALO NIAGARA INTL. AIRPORT
Department 0071 MAINTENANCE FACILITIES

Account	Description	2009-10 Actual	2010-11 Budget	2010-11 Sept. YTD Actual	2011-12 Req Budget	VARIANCE From Budget
510	EMPLOYEE SALARIES	137,933	143,214	109,021	148,774	5,560
515	EMPLOYEE BENEFITS	53,403	65,731	49,725	70,982	5,251
591	PROJECTS	9,983-		27,941-	10,821-	10,821-
592	DIVISION OPERATIONS	181,357-	208,945-	130,808-	208,935-	10
TOTAL EXPENSES		4-		3-		

QB201 Date 03/24/11
Time 08:34

Niagara Frontier Transportation Authority
Print Personnel Budget Worksheets 2010 - 2011

02 BUFFALO NIAGARA INTL. AIRPORT
0071

EMPLOYEE GROUP: PB-ALL

Job Description	Grade/Step		Base Salary	Increase Amount	Longevity Amount	Scheduled Amount
-----	-----	-----	-----	-----	-----	-----
SR. BUS SHELTER TECH.	8	6	51,118	2,586	1,750	55,454
BUS SHELTER TECHNICIAN	6	6	42,826	2,166	1,400	46,392
ASST. BUS SHELTER TECH	4	4	33,011	3,103		36,114
UNION Totals	3		126,955	7,855	3,150	137,960
Department Totals	3		126,955	7,855	3,150	137,960

NIAGARA FRONTIER TRANSPORTATION AUTHORITY
(ACCOUNTCO, ACCOUNTUNIT, ACCOUNT)
BUDGET WORKSHEETS - Fiscal Year 2011-12

Company 2 NFT Metro System, Inc.
Division 40 METRO TRANS. AND MAINTENANCE
Department 4049 BUS SHELTERS

Account	Description	2009-10 Actual	2010-11 Budget	2010-11 Sept. YTD Actual	2011-12 Req Budget	VARIANCE From Budget
531	ELECTRIC POWER	18,524	19,450	14,163	19,633	183
534	TELEPHONE	82			85	85
571	CONSULTANTS/OUTSIDE SERVICES	217,353	228,445	209,910	226,435	2,010-
591	PROJECTS			1,937-		
TOTAL	EXPENSES	235,959	247,895	222,136	246,153	1,742-

NIAGARA FRONTIER TRANSPORTATION AUTHORITY
(ACCOUNTCO, ACCOUNTUNIT, ACCOUNT)
BUDGET WORKSHEETS - Fiscal Year 2011-12

Company 1 Niagara Frontier Transportation Authority
Division 02 BUFFALO NIAGARA INTL. AIRPORT
Department 0211 AIRCRAFT RESCUE FIREFIGHTING

Account	Description	2009-10 Actual	2010-11 Budget	2010-11 Sept. YTD Actual	2011-12 Req Budget	VARIANCE From Budget
510	EMPLOYEE SALARIES	2,000,219	2,168,000	1,587,851	2,221,690	53,690
515	EMPLOYEE BENEFITS	763,598	899,037	717,034	962,871	63,834
520	MAINTENANCE AND REPAIRS	43,169	54,800	52,158	48,950	5,850-
524	AUTOMOTIVE	24,725	30,147	21,502	35,571	5,424
526	JANITORIAL AND LAUNDRY	3,241	2,999	1,901	3,100	101
531	ELECTRIC POWER	11,559	13,378	8,590	13,779	401
532	GAS	13,248	13,727	5,466	14,203	476
534	TELEPHONE	6,579	6,782	7,623	6,715	67-
541	INSURANCE	2,672	2,933	378	638	2,295-
552	FIRE FIGHTING AND RESCUE	121,051	73,560	37,382	65,660	7,900-
571	CONSULTANTS/OUTSIDE SERVICES	1,780		3,782	2,000	2,000
577	EMPLOYEE TRAINING	24,878	37,000	25,249	24,878	12,122-
580	GENERAL OFFICE	8,984	3,000	4,180	3,000	
	TOTAL EXPENSES	3,025,703	3,305,363	2,473,096	3,403,055	97,692

QB201 Date 03/24/11
Time 08:34

Niagara Frontier Transportation Authority
Print Personnel Budget Worksheets 2010 - 2011

02 BUFFALO NIAGARA INTL. AIRPORT
0211 AIRCRAFT RESCUE FIREFIGHTING

EMPLOYEE GROUP: PB-ALL

Job Description	Grade/Step	Base Salary	Increase Amount	Longevity Amount	Scheduled Amount
UNION Totals	40	1,589,805	103,963	26,900	1,720,668
Department Totals	41	1,663,965	103,963	28,700	1,796,628

NIAGARA FRONTIER TRANSPORTATION AUTHORITY
(ACCOUNTCO, ACCOUNTUNIT, ACCOUNT)
BUDGET WORKSHEETS - Fiscal Year 2011-12

Company 1 Niagara Frontier Transportation Authority
Division 02 BUFFALO NIAGARA INTL. AIRPORT
Department 0212 TRANSIT POLICE

Account	Description	2009-10 Actual	2010-11 Budget	2010-11 Sept. YTD Actual	2011-12 Req Budget	VARIANCE From Budget
520	MAINTENANCE AND REPAIRS	8,870	7,460	6,645	8,416	956
524	AUTOMOTIVE	133,521	109,440	113,913	129,136	19,696
526	JANITORIAL AND LAUNDRY	12,250	12,903	8,854	14,790	1,887
534	TELEPHONE	2,153	2,225	3,443	2,200	25-
553	POLICE PROTECTION	4,491,585	4,977,311	3,632,728	4,780,079	197,232-
571	CONSULTANTS/OUTSIDE SERVICES	324		21,271		
572	RENT EXPENSE	138,996	139,000	104,247	139,000	
580	GENERAL OFFICE	8,876	7,724	18,558	9,141	1,417
TOTAL	EXPENSES	4,796,575	5,256,063	3,909,659	5,082,762	173,301-

NIAGARA FRONTIER TRANSPORTATION AUTHORITY
(ACCOUNTCO, ACCOUNTUNIT, ACCOUNT)
BUDGET WORKSHEETS - Fiscal Year 2011-12

Company 1 Niagara Frontier Transportation Authority
Division 02 BUFFALO NIAGARA INTL. AIRPORT
Department 0219 LANDING AREA

Account	Description	2009-10 Actual	2010-11 Budget	2010-11 Sept. YTD Actual	2011-12 Req Budget	VARIANCE From Budget
401	LANDING FEES	13,062,670-	13,880,495-	10,608,277-	14,775,092-	894,597-
403	TERMINAL RAMP FEES	1,744,704-	1,671,427-	1,251,891-	1,683,544-	12,117-
433	GROUND RENTALS	205-	150-	85-	200-	50-
TOTAL REVENUES		14,807,579-	15,552,072-	11,860,253-	16,458,836-	906,764-

NIAGARA FRONTIER TRANSPORTATION AUTHORITY
(ACCOUNTCO, ACCOUNTUNIT, ACCOUNT)
BUDGET WORKSHEETS - Fiscal Year 2011-12

Company 1 Niagara Frontier Transportation Authority
Division 02 BUFFALO NIAGARA INTL. AIRPORT
Department 0219 LANDING AREA

Account	Description	2009-10 Actual	2010-11 Budget	2010-11 Sept. YTD Actual	2011-12 Req Budget	VARIANCE From Budget
510	EMPLOYEE SALARIES	2,098,686	2,217,615	1,549,780	2,276,003	58,388
515	EMPLOYEE BENEFITS	812,001	962,971	705,711	1,034,944	71,973
520	MAINTENANCE AND REPAIRS	1,035,816	976,029	406,298	1,175,805	199,776
524	AUTOMOTIVE	58,336	53,000	43,649	66,456	13,456
526	JANITORIAL AND LAUNDRY	1,307	5,600	2,801	6,000	400
527	ENVIRONMENTAL	340,901	414,750	82,897	370,053	44,697-
530	GROUNDS & LANDSCAPING	5,468	5,000	5,525	5,000	
531	ELECTRIC POWER	217,297	202,910	115,885	254,147	51,237
532	GAS	7,735	6,711	3,371	8,292	1,581
533	WATER	46,186	49,917	48,466	47,900	2,017-
534	TELEPHONE	10,182	10,803	6,934	10,542	261-
541	INSURANCE	40,782	42,380	30,435	44,076	1,696
542	CLAIM LOSSES	1,963	5,000	8,212-	5,000	
554	TRAFFIC CONTROL	229,617	230,000	173,497	230,000	
571	CONSULTANTS/OUTSIDE SERVICES	103,240	109,820	58,505	104,160	5,660-
573	PROVISIONS AND RESERVES	74,002		398-		
576	EMPLOYEE TRAVEL	18				
577	EMPLOYEE TRAINING	28,724	32,459	27,796	28,724	3,735-
578	POSTAGE	78		19	100	100
580	GENERAL OFFICE	19,980	13,900	10,583	8,000	5,900-
591	PROJECTS	283-	1,030-	471-		1,030
592	DIVISION OPERATIONS	3,736-	3,090-	8,405-	3,183-	93-

QB204 Date 03/23/11
Time 14:17

NIAGARA FRONTIER TRANSPORTATION AUTHORITY
(ACCOUNTCO, ACCOUNTUNIT, ACCOUNT)
BUDGET WORKSHEETS - Fiscal Year 2011-12

Page 10
CREDITS = (-)
DEBITS = (+)

Company 1 Niagara Frontier Transportation Authority
Division 02 BUFFALO NIAGARA INTL. AIRPORT
Department 0219 LANDING AREA

Account	Description	2009-10 Actual	2010-11 Budget	2010-11 Sept. YTD Actual	2011-12 Req Budget	VARIANCE From Budget
TOTAL EXPENSES		5,128,300	5,334,745	3,254,666	5,672,019	337,274

02 BUFFALO NIAGARA INTL. AIRPORT
0219 LANDING AREA

EMPLOYEE GROUP: PB-ALL

Job Description	Grade/Step	Base Salary	Increase Amount	Longevity Amount	Scheduled Amount
AIRFIELD SUPERINTENDEN	17	80,330		500	80,830
NON-REP Totals	1	80,330		500	80,830
AIRFIELD SUPERVISOR	3 4	59,449	3,317	1,800	64,566
AIRFIELD SUPERVISOR	3 4	59,449	3,317	1,400	64,166
ELECTRICAL SUPERVISOR	3 4	57,509	5,257	1,100	63,866
AIRFIELD SUPERVISOR	3 4	59,449	3,317		62,766
AIRFIELD SUPERVISOR	3 3	55,570	5,148	700	61,418
Landscape Supervisor B	1 4	50,827	4,884		55,711
ELECTRICIAN	A 6	49,020		1,100	50,120
ELECTRICIAN	A 6	49,020		900	49,920
SR. GROUNDSPERSON	A 6	47,980		1,800	49,780
SR. GROUNDSPERSON	A 6	47,980		1,400	49,380
GROUNDSPERSON I	A 6	47,980		1,400	49,380
GROUNDSPERSON I	A 6	47,980		900	48,880
GROUNDSPERSON I	A 6	47,980		900	48,880
GROUNDSPERSON II	A 6	47,980		700	48,680
GROUNDSPERSON I	A 6	47,980		700	48,680
GROUNDSPERSON I	A 6	47,980		700	48,680
GROUNDSPERSON I	A 6	47,980			47,980
GROUNDSPERSON II	A 6	47,980			47,980
GROUNDSPERSON II	A 6	47,980			47,980
GROUNDSPERSON I	A 6	45,943	2,037		47,980
GROUNDSPERSON I	A 6	47,980			47,980
GROUNDSPERSON I	A 6	45,943	2,037		47,980
GROUNDSPERSON I	A 6	45,943	2,037		47,980
GROUNDSPERSON I	A 6	45,900			45,900
ELECTRICIAN	A 4	42,780	1,961		44,740
GROUNDSPERSON II	B 6	40,349	1,929		42,278
GROUNDSPERSON II	B 6	40,349	1,929		42,278
FIELDPERSON	B 6	40,349	1,929		42,278
GROUNDSPERSON II	B 5	38,511	1,838		40,349
GROUNDSPERSON II	B 5	38,511	1,838		40,349
GROUNDSPERSON II	B 5	38,511	1,838		40,349
GROUNDSPERSON II	B 5	38,511	1,838		40,349
ADMINISTRATIVE ASSISTA	4 6	37,299	1,887	500	39,686
FIELDPERSON	B 4	36,762	1,749		38,511
FIELDPERSON	B 4	36,762	1,749		38,511
UNION Totals	35	1,628,476	51,836	16,000	1,696,311
Department Totals	36	1,708,806	51,836	16,500	1,777,141

QB204 Date 03/23/11
Time 14:17

NIAGARA FRONTIER TRANSPORTATION AUTHORITY
(ACCOUNTCO, ACCOUNTUNIT, ACCOUNT)
BUDGET WORKSHEETS - Fiscal Year 2011-12

Page 11
CREDITS = (-)
DEBITS = (+)

Company 1 Niagara Frontier Transportation Authority
Division 02 BUFFALO NIAGARA INTL. AIRPORT
Department 0220 FUEL FARM

Account	Description	2009-10 Actual	2010-11 Budget	2010-11 Sept. YTD Actual	2011-12 Req Budget	VARIANCE From Budget
462	REBILLINGS	850,571-	960,592-	716,678-	933,856-	26,736
	TOTAL REVENUES	850,571-	960,592-	716,678-	933,856-	26,736

NIAGARA FRONTIER TRANSPORTATION AUTHORITY
(ACCOUNTCO, ACCOUNTUNIT, ACCOUNT)
BUDGET WORKSHEETS - Fiscal Year 2011-12

Company 1 Niagara Frontier Transportation Authority
Division 02 BUFFALO NIAGARA INTL. AIRPORT
Department 0220 FUEL FARM

Account	Description	2009-10 Actual	2010-11 Budget	2010-11 Sept. YTD Actual	2011-12 Req Budget	VARIANCE From Budget
510	EMPLOYEE SALARIES	308,904	309,788	238,308	312,287	2,499
515	EMPLOYEE BENEFITS	120,627	135,092	110,412	142,166	7,074
520	MAINTENANCE AND REPAIRS	108,896	159,500	118,701	119,175	40,325-
524	AUTOMOTIVE			13,061		
526	JANITORIAL AND LAUNDRY	1,229	4,000		1,300	2,700-
527	ENVIRONMENTAL	6,275	18,600	7,776	19,260	660
530	GROUNDS & LANDSCAPING		6,000			6,000-
531	ELECTRIC POWER	45,792	49,915	35,491	51,412	1,497
533	WATER	452	477	346	459	18-
534	TELEPHONE	1,797	1,980	926	1,896	84-
571	CONSULTANTS/OUTSIDE SERVICES	5,328	12,146	7,043	9,000	3,146-
577	EMPLOYEE TRAINING	330	1,409	500	330	1,079-
578	POSTAGE	560		618	600	600
580	GENERAL OFFICE	5,312	5,500	6,118	5,200	300-
592	DIVISION OPERATIONS	34,855-	32,960-	19,537-	35,020-	2,060-
	TOTAL EXPENSES	570,647	671,447	519,763	628,065	43,382-

QB201 Date 03/24/11
Time 08:34

Niagara Frontier Transportation Authority
Print Personnel Budget Worksheets 2010 - 2011

02 BUFFALO NIAGARA INTL. AIRPORT
0220 FUEL FARM

EMPLOYEE GROUP: PB-ALL

Job Description	Grade/Step		Base Salary	Increase Amount	Longevity Amount	Scheduled Amount
-----	-----	-----	-----	-----	-----	-----
FUEL FARM SUPERVISOR	3	4	59,449	3,317	1,400	64,166
FUEL FARM TECHNICIAN	A	6	47,980		1,800	49,780
FUEL FARM TECHNICIAN	A	6	47,980		1,400	49,380
FUEL FARM TECHNICIAN	A	6	47,980		1,400	49,380
FUEL FARM TECHNICIAN	A	6	47,980		1,400	49,380
UNION Totals		5	251,369	3,317	7,400	262,086
Department Totals		5	251,369	3,317	7,400	262,086

NIAGARA FRONTIER TRANSPORTATION AUTHORITY
(ACCOUNTCO, ACCOUNTUNIT, ACCOUNT)
BUDGET WORKSHEETS - Fiscal Year 2011-12

Company 1 Niagara Frontier Transportation Authority
Division 02 BUFFALO NIAGARA INTL. AIRPORT
Department 0230 AFSS

Account	Description	2009-10 Actual	2010-11 Budget	2010-11 Sept. YTD Actual	2011-12 Req Budget	VARIANCE From Budget
431	BUILDING SPACE	48,444-	176,800-	36,415-	181,888-	5,088-
	TOTAL REVENUES	48,444-	176,800-	36,415-	181,888-	5,088-

NIAGARA FRONTIER TRANSPORTATION AUTHORITY
(ACCOUNTCO, ACCOUNTUNIT, ACCOUNT)
BUDGET WORKSHEETS - Fiscal Year 2011-12

Company 1 Niagara Frontier Transportation Authority
Division 02 BUFFALO NIAGARA INTL. AIRPORT
Department 0230 AFSS

Account	Description	2009-10 Actual	2010-11 Budget	2010-11 Sept. YTD Actual	2011-12 Req Budget	VARIANCE From Budget
520	MAINTENANCE AND REPAIRS	5,879	1,500		2,000	500
530	GROUNDS & LANDSCAPING			1,250	1,800	1,800
531	ELECTRIC POWER		20,000		15,450	4,550-
532	GAS	4,105		2,338	4,401	4,401
TOTAL	EXPENSES	9,984	21,500	3,588	23,651	2,151

NIAGARA FRONTIER TRANSPORTATION AUTHORITY
(ACCOUNTCO, ACCOUNTUNIT, ACCOUNT)
BUDGET WORKSHEETS - Fiscal Year 2011-12

Company 1 Niagara Frontier Transportation Authority
Division 02 BUFFALO NIAGARA INTL. AIRPORT
Department 0245 TERMINAL BUILDING

Account	Description	2009-10 Actual	2010-11 Budget	2010-11 Sept. YTD Actual	2011-12 Req Budget	VARIANCE From Budget
431	BUILDING SPACE	7,543,438-	7,948,940-	5,746,106-	7,907,636-	41,304
441	CONCESSIONS	3,338,289-	3,213,550-	2,346,827-	3,188,371-	25,179
442	COMMISSIONS	35,535-	20,000-	23,927-		20,000
462	REBILLINGS	325,536-	328,315-	212,843-	351,230-	22,915-
492	EQUIPMENT AND SERVICES	2,140,251-	2,275,150-	1,706,842-	2,382,812-	107,662-
494	ADVERTISING REVENUES	406,383-	418,578-	370,776-	602,371-	183,793-
TOTAL REVENUES		13,789,432-	14,204,533-	10,407,321-	14,432,420-	227,887-

NIAGARA FRONTIER TRANSPORTATION AUTHORITY
(ACCOUNTCO, ACCOUNTUNIT, ACCOUNT)
BUDGET WORKSHEETS - Fiscal Year 2011-12

Company 1 Niagara Frontier Transportation Authority
Division 02 BUFFALO NIAGARA INTL. AIRPORT
Department 0245 TERMINAL BUILDING

Account	Description	2009-10 Actual	2010-11 Budget	2010-11 Sept. YTD Actual	2011-12 Req Budget	VARIANCE From Budget
510	EMPLOYEE SALARIES	1,966,209	1,969,468	1,484,122	1,924,521	44,947-
515	EMPLOYEE BENEFITS	766,368	886,839	677,590	906,552	19,713
520	MAINTENANCE AND REPAIRS	4,210,034	4,684,683	3,332,079	4,688,093	3,410
526	JANITORIAL AND LAUNDRY	430,015	446,757	281,125	408,445	38,312-
530	GROUNDS & LANDSCAPING	50,771	45,500	53,870	66,500	21,000
531	ELECTRIC POWER	1,229,655	1,390,500	1,075,950	1,495,715	105,215
532	GAS	283,157	289,784	111,664	303,558	13,774
533	WATER	35,981	38,311	29,015	38,114	197-
534	TELEPHONE	12,893	13,921	8,722	13,468	453-
541	INSURANCE	368,281	382,749	274,858	398,043	15,294
542	CLAIM LOSSES	17,731	31,410	74,169-	31,410	
554	TRAFFIC CONTROL	341,947	350,000	259,104	342,000	8,000-
571	CONSULTANTS/OUTSIDE SERVICES	19,041	13,030	13,238	24,000	10,970
573	PROVISIONS AND RESERVES	25,826-				
577	EMPLOYEE TRAINING	5,864	7,907	304	5,864	2,043-
580	GENERAL OFFICE	11,527	2,400	10,113	5,000	2,600
TOTAL	EXPENSES	9,723,648	10,553,259	7,537,585	10,651,283	98,024

QB201 Date 03/24/11
Time 08:34

Niagara Frontier Transportation Authority
Print Personnel Budget Worksheets 2010 - 2011

02 BUFFALO NIAGARA INTL. AIRPORT
0245 TERMINAL BUILDING

EMPLOYEE GROUP: PB-ALL

Job Description	Grade/Step	Base Salary	Increase Amount	Longevity Amount	Scheduled Amount
CUSTODIAN II	F 4	24,469	1,054		25,523
CUSTODIAN II	F 4	24,469	1,054		25,523
CUSTODIAN II	F 4	24,469	1,054		25,523
CUSTODIAN II	F 4	24,469	1,054		25,523
CUSTODIAN II	F 4	24,469	1,054		25,523
CUSTODIAN II	F 4	24,469	1,054		25,523
CUSTODIAN II	F 4	24,469	1,054		25,523
CUSTODIAN II	F 4	24,469	1,054		25,523
CUSTODIAN II	F 4	24,469	1,054		25,523
CUSTODIAN II	F 4	24,469	1,054		25,523
CUSTODIAN	F 3	23,465	1,004		24,469
CUSTODIAN	A 6	23,465	1,004		24,469
UNION Totals	50	1,489,876	43,490	15,400	1,548,766
Department Totals	54	1,740,176	43,490	15,400	1,799,066

NIAGARA FRONTIER TRANSPORTATION AUTHORITY
(ACCOUNTCO, ACCOUNTUNIT, ACCOUNT)
BUDGET WORKSHEETS - Fiscal Year 2011-12

Company 1 Niagara Frontier Transportation Authority
Division 02 BUFFALO NIAGARA INTL. AIRPORT
Department 0259 GENERAL AVIATION

Account	Description	2009-10	2010-11	2010-11	2011-12	VARIANCE
		Actual	Budget	Sept. YTD Actual	Req Budget	
431	BUILDING SPACE	192,263-	196,032-	145,547-	198,844-	2,812-
433	GROUND RENTALS	103,402-	101,999-	78,277-	105,905-	3,906-
439	OTHER RENTALS	92,431-	55,602-	48,433-	63,160-	7,558-
TOTAL REVENUES		388,096-	353,633-	272,257-	367,909-	14,276-

QB204 Date 03/23/11
Time 14:17

NIAGARA FRONTIER TRANSPORTATION AUTHORITY
(ACCOUNTCO, ACCOUNTUNIT, ACCOUNT)
BUDGET WORKSHEETS - Fiscal Year 2011-12

Page 18
CREDITS = (-)
DEBITS = (+)

Company 1 Niagara Frontier Transportation Authority
Division 02 BUFFALO NIAGARA INTL. AIRPORT
Department 0259 GENERAL AVIATION

Account	Description	2009-10 Actual	2010-11 Budget	2010-11 Sept. YTD Actual	2011-12 Req Budget	VARIANCE From Budget
533	WATER	4,713	4,845	3,582	4,728	117-
	TOTAL EXPENSES	4,713	4,845	3,582	4,728	117-

NIAGARA FRONTIER TRANSPORTATION AUTHORITY
(ACCOUNTCO, ACCOUNTUNIT, ACCOUNT)
BUDGET WORKSHEETS - Fiscal Year 2011-12

Company 1 Niagara Frontier Transportation Authority
Division 02 BUFFALO NIAGARA INTL. AIRPORT
Department 0271 MAINTENANCE GARAGE

Account	Description	2009-10 Actual	2010-11 Budget	2010-11 Sept. YTD Actual	2011-12 Req Budget	VARIANCE From Budget
510	EMPLOYEE SALARIES	441,117	471,877	350,461	481,546	9,669
515	EMPLOYEE BENEFITS	173,405	211,539	160,678	225,570	14,031
520	MAINTENANCE AND REPAIRS	78,380	27,716	12,435	22,943	4,773-
524	AUTOMOTIVE	525,556	526,998	346,312	542,576	15,578
526	JANITORIAL AND LAUNDRY	12,895	7,200	8,514	9,432	2,232
531	ELECTRIC POWER	20,904	23,848	14,305	24,563	715
532	GAS	42,428	50,828	16,836	45,485	5,343-
534	TELEPHONE	1,516	1,653	1,089	1,591	62-
541	INSURANCE	11,351	11,796	8,470	12,268	472
542	CLAIM LOSSES	546	1,000	2,286-	1,000	
571	CONSULTANTS/OUTSIDE SERVICES	29,156	15,236	5,876	12,100	3,136-
577	EMPLOYEE TRAINING		3,189	3,148		3,189-
578	POSTAGE	20				
580	GENERAL OFFICE	1,727	1,199	1,127	1,200	1
591	PROJECTS	1,768-				
592	DIVISION OPERATIONS	48,960-	56,650-	30,464-	58,350-	1,700-
TOTAL	EXPENSES	1,288,273	1,297,429	896,501	1,321,924	24,495

02 BUFFALO NIAGARA INTL. AIRPORT
0271 MAINTENANCE GARAGE

EMPLOYEE GROUP: PB-ALL

Job Description	Grade/Step		Base Salary	Increase Amount	Longevity Amount	Scheduled Amount
MAINT. FACILITY SUPERV	3	4	59,449	3,317	1,800	64,566
ASST. MOTOR EQUIP. SUP	1	4	52,766	2,944	700	56,410
SUPV. OF SUPPLIES	7	6	47,008	2,378	1,750	51,136
MECHANIC	A	6	49,020		700	49,720
MECHANIC	A	6	49,020		700	49,720
MECHANIC	A	6	46,983	997		47,980
MECHANIC	A	6	46,983	997		47,980
MECHANIC	B	5	43,196	1,910		45,106
UNION Totals		8	394,425	12,543	5,650	412,618
Department Totals		8	394,425	12,543	5,650	412,618

NIAGARA FRONTIER TRANSPORTATION AUTHORITY
(ACCOUNTCO, ACCOUNTUNIT, ACCOUNT)
BUDGET WORKSHEETS - Fiscal Year 2011-12

Company 1 Niagara Frontier Transportation Authority
Division 02 BUFFALO NIAGARA INTL. AIRPORT
Department 0274 PARKING LOTS AND STRUCTURES

Account	Description	2009-10 Actual	2010-11 Budget	2010-11 Sept. YTD Actual	2011-12 Req Budget	VARIANCE From Budget
431	BUILDING SPACE	603,468-	621,572-	452,601-	603,468-	18,104
433	GROUND RENTALS	8,010-	8,247-	6,007-	8,010-	237
441	CONCESSIONS	23,132,227-	24,704,515-	18,194,293-	25,284,608-	580,093-
462	REBILLINGS	205,495-	131,995-	84,495-	130,956-	1,039
492	EQUIPMENT AND SERVICES	36,000-	36,000-	27,000-	36,000-	
TOTAL REVENUES		23,985,200-	25,502,329-	18,764,396-	26,063,042-	560,713-

NIAGARA FRONTIER TRANSPORTATION AUTHORITY
(ACCOUNTCO, ACCOUNTUNIT, ACCOUNT)
BUDGET WORKSHEETS - Fiscal Year 2011-12

Company 1 Niagara Frontier Transportation Authority
Division 02 BUFFALO NIAGARA INTL. AIRPORT
Department 0274 PARKING LOTS AND STRUCTURES

Account	Description	2009-10 Actual	2010-11 Budget	2010-11 Sept. YTD Actual	2011-12 Req Budget	VARIANCE From Budget
520	MAINTENANCE AND REPAIRS	524,260	604,616	180,776	545,100	59,516-
524	AUTOMOTIVE	295,850	290,000	241,678	334,894	44,894
526	JANITORIAL AND LAUNDRY			6,230	6,700	6,700
530	GROUNDS & LANDSCAPING	63,036	45,502	56,168	66,500	20,998
531	ELECTRIC POWER	208,487	156,532	116,516	234,728	78,196
532	GAS	10,607	7,211	5,863	11,371	4,160
533	WATER	19,560	21,022	15,809	20,762	260-
534	TELEPHONE	296	310	222	304	6-
571	CONSULTANTS/OUTSIDE SERVICES	4,735,130	5,093,915	3,604,805	5,144,757	50,842
572	RENT EXPENSE	85,500	109,482	64,766	99,600	9,882-
TOTAL	EXPENSES	5,942,726	6,328,590	4,292,833	6,464,716	136,126

NIAGARA FRONTIER TRANSPORTATION AUTHORITY
(ACCOUNTCO, ACCOUNTUNIT, ACCOUNT)
BUDGET WORKSHEETS - Fiscal Year 2011-12

Company 1 Niagara Frontier Transportation Authority
Division 02 BUFFALO NIAGARA INTL. AIRPORT
Department 0276

Account	Description	2009-10 Actual	2010-11 Budget	2010-11 Sept. YTD Actual	2011-12 Req Budget	VARIANCE From Budget
510	EMPLOYEE SALARIES	945,480	1,003,622	740,504	941,212	62,410-
515	EMPLOYEE BENEFITS	369,452	441,818	340,294	431,240	10,578-
520	MAINTENANCE AND REPAIRS	37,307	11,497	14,025	25,000	13,503
524	AUTOMOTIVE	17,911	16,500	14,853	17,829	1,329
526	JANITORIAL AND LAUNDRY	9,905	11,000	2,856	6,500	4,500-
531	ELECTRIC POWER	9,428	10,236	7,030	10,543	307
532	GAS	7,278	8,068	3,666	7,802	266-
533	WATER	724	667	564	679	12
534	TELEPHONE	12,693	9,851	9,708	11,368	1,517
541	INSURANCE	2,595	1,856	1,605	1,931	75
542	CLAIM LOSSES	2,292				
571	CONSULTANTS/OUTSIDE SERVICES	13,771	515	1,216	500	15-
575	PRINTING & ADVERTISING	11-				
577	EMPLOYEE TRAINING	2,845	2,656		2,500	156-
578	POSTAGE	14			50	50
580	GENERAL OFFICE	6,232	6,000	6,125	6,000	
591	PROJECTS	49,120-		69,664-		
592	DIVISION OPERATIONS	1,388,812-	1,524,294-	1,072,795-	1,463,154-	61,140
TOTAL	EXPENSES	16-	8-	13-		8

02 BUFFALO NIAGARA INTL. AIRPORT
0276

EMPLOYEE GROUP: PE-ALL

Job Description	Grade/Step		Base Salary	Increase Amount	Longevity Amount	Scheduled Amount
MANAGER, FMD	16	1	76,219		1,500	77,719
MAINT. FACILITY SUPERV	14	0	67,000		1,800	68,800
MAINT. FACILITY SUPERV	14		61,800			61,800
NON-REP Totals		3	205,019		3,300	208,319
TRADE PERSON UTILITY/C	A	6	53,180		1,800	54,980
TRADE PERSON UTILITY/H	A	6	53,180		1,400	54,580
TRADE PERSON UTILITY/C	A	6	53,180		1,400	54,580
TRADE PERSON UTILITY/H	A	6	53,180		1,100	54,280
TRADE PERSON UTILITY/C	A	6	53,180		700	53,880
TRADES PERSON UTILITY/	A	6	50,103	3,077		53,180
TRADE PERSON UTILTIY/E	A	4	47,356	2,391		49,747
SR. MAINTENANCE PERSON	B	6	46,983	997		47,980
DATA CONTROL CLERK	4	6	37,299	1,887	650	39,836
TRADE PERSON UTILITY/P	A	4	36,773	1,738		38,511
ADMINISTRATIVE ASSISTA	4	4	33,010	3,104		36,114
TRADE PERSON UTILITY/M	B	2	33,634	1,462		35,096
TRADE PERSON UTILITY/E	B	2	33,634	1,463		35,096
TRADE PERSON UTILITY/S	B	2	33,634	1,463		35,096
UNION Totals		14	618,326	17,582	7,050	642,956
Department Totals		17	823,345	17,582	10,350	851,275

BUFFALO NIAGARA INTERNATIONAL AIRPORT

PROJECT TITLE	PROJECT NUMBER	PRTY CL	JUST. CL	FUND SOURCE	TOTAL PROJECT BUDGET	PROJECT LIFE ACTUAL AS OF 7/19/10	TOTAL FORECASTED SPENDING 7/20/10	FISCAL YEAR 2011/2012	FISCAL YEAR 2012/2013	FISCAL YEAR 2013/2014	FISCAL YEAR 2014/2015	FISCAL YEAR 2015/2016	OUT YEARS
BNIA													
MASTER PLAN UPDATE & PAVEMENT MGMT	2-2507	M	NR	FAA	\$1,128,105	\$25,125	\$618,394	\$480,836	\$3,750	\$0	\$0	\$0	\$0
AND OBSTRUCTION STUDY AND GIS IMAGING				NYSDOT	\$188,018	\$4,188	\$103,066	\$80,139	\$625	\$0	\$0	\$0	\$0
				FUTURE PFC	\$188,018	\$4,188	\$103,066	\$80,139	\$625	\$0	\$0	\$0	\$0
				TOTAL	\$1,504,140	\$33,500	\$824,525	\$641,115	\$5,000	\$0	\$0	\$0	\$0
ENVIRONMENTAL ASSESSMENT													
	--	M	NR	FAA	\$262,500	\$0	\$0	\$0	\$150,000	\$97,500	\$15,000	\$0	\$0
				NYSDOT	\$43,750	\$0	\$0	\$0	\$25,000	\$16,250	\$2,500	\$0	\$0
				FUTURE PFC	\$43,750	\$0	\$0	\$0	\$25,000	\$16,250	\$2,500	\$0	\$0
				TOTAL	\$350,000	\$0	\$0	\$0	\$200,000	\$130,000	\$20,000	\$0	\$0
NOISE COMPATABILITY PROGRAM													
FFY 06	2-2404	M	NI	FAA	\$57,511,894	\$17,334,971	\$3,224,590	\$4,729,722	\$4,727,904	\$5,657,890	\$5,976,572	\$6,279,803	\$9,580,441
CLOSED FFY 07	2-2466			NYSDOT	\$7,188,987	\$2,166,871	\$403,074	\$591,215	\$590,988	\$707,236	\$747,072	\$784,975	\$1,197,555
FFY 08	2-2468			PFC	\$7,188,987	\$2,166,871	\$403,074	\$591,215	\$590,988	\$707,236	\$747,072	\$784,975	\$1,197,555
CLOSED FFY 08 PART 2	2-2476			TOTAL	\$71,889,867	\$21,668,714	\$4,030,738	\$5,912,153	\$5,909,880	\$7,072,362	\$7,470,715	\$7,849,754	\$11,975,551
FFY 09	2-2483												
FFY 10	2-2514												
REHAB. INTERSECTION 5/23 AND 14/32													
	--			BNIA CAP RES.	\$250,000	\$0	\$0	\$250,000	\$0	\$0	\$0	\$0	\$0
RUNWAY 5/23 EXTENSION & TW "A" IMPR.													
	2-2308		SR	FAA	\$25,750,401	\$25,733,544	\$16,857	\$0	\$0	\$0	\$0	\$0	\$0
				NYSDOT	\$4,291,733	\$4,291,732	\$1	\$0	\$0	\$0	\$0	\$0	\$0
				PFC (match)	\$4,291,733	\$4,291,732	\$1	\$0	\$0	\$0	\$0	\$0	\$0
				PFC	\$1,500,003	\$1,063,840	\$436,163	\$0	\$0	\$0	\$0	\$0	\$0
				TOTAL	\$35,833,870	\$35,380,848	\$453,022	\$0	\$0	\$0	\$0	\$0	\$0
RELIGN TW "M" - R/W 5/23 - CARGO RAMP & TW "N"													
	--		NI	FAA	\$6,514,908	\$0	\$0	\$0	\$0	\$0	\$489,493	\$6,025,415	\$0
				NYSDOT	\$1,085,818	\$0	\$0	\$0	\$0	\$0	\$81,582	\$1,004,236	\$0
				FUTURE PFC	\$1,085,818	\$0	\$0	\$0	\$0	\$0	\$81,582	\$1,004,236	\$0
				TOTAL	\$8,686,544	\$0	\$0	\$0	\$0	\$0	\$652,657	\$8,033,887	\$0
DESIGN/CONSTRUCT TW "S" FROM TW "Q"-"A"													
	--		NI	FAA	\$13,416,594	\$0	\$0	\$0	\$0	\$0	\$0	\$1,009,735	\$12,406,859
				NYSDOT	\$2,236,099	\$0	\$0	\$0	\$0	\$0	\$0	\$168,289	\$2,067,810
				PFC	\$2,236,099	\$0	\$0	\$0	\$0	\$0	\$0	\$168,289	\$2,067,810
				TOTAL	\$17,888,792	\$0	\$0	\$0	\$0	\$0	\$0	\$1,346,313	\$16,542,479
UPGRADE TERMINAL RESTROOMS													
	--		SR	FAA	\$798,002	\$0	\$0	\$0	\$78,242	\$719,759	\$0	\$0	\$0
				NYSDOT	\$133,000	\$0	\$0	\$0	\$13,040	\$119,960	\$0	\$0	\$0
				PFC	\$133,000	\$0	\$0	\$0	\$13,040	\$119,960	\$0	\$0	\$0
				TOTAL	\$1,064,002	\$0	\$0	\$0	\$104,323	\$959,679	\$0	\$0	\$0

BUFFALO NIAGARA INTERNATIONAL AIRPORT

PROJECT TITLE	PROJECT NUMBER	PRTY CL	JUST. CL	FUND SOURCE	TOTAL PROJECT BUDGET	PROJECT LIFE ACTUAL AS OF 7/19/10	TOTAL FORECASTED SPENDING 7/20/10	FISCAL YEAR 2011/2012	FISCAL YEAR 2012/2013	FISCAL YEAR 2013/2014	FISCAL YEAR 2014/2015	FISCAL YEAR 2015/2016	OUT YEARS
ARFF BUILDING ADDITION	--		NI	FAA	\$745,782	\$0	\$0	\$0	\$0	\$70,748	\$875,035	\$0	\$0
				NYS DOT	\$124,297	\$0	\$0	\$0	\$0	\$11,791	\$112,506	\$0	\$0
				FUTURE PFC	\$124,297	\$0	\$0	\$0	\$0	\$11,791	\$112,506	\$0	\$0
				TOTAL	\$994,376	\$0	\$0	\$0	\$0	\$94,330	\$900,046	\$0	\$0
ARFF COMMAND AND CONTROL CENTER REPLACE.	2-2478		NI	FAA	\$309,375	\$141,358	\$168,020	\$0	\$0	\$0	\$0	\$0	\$0
				NYS DOT	\$51,563	\$23,559	\$28,003	\$0	\$0	\$0	\$0	\$0	\$0
				PFC	\$51,563	\$23,559	\$28,003	\$0	\$0	\$0	\$0	\$0	\$0
				TOTAL	\$412,500	\$188,474	\$224,026	\$0	\$0	\$0	\$0	\$0	\$0
ARFF GARAGE VENTILATION UPGRADE	--		NI	PENDING GRANT	\$206,856	\$0	\$36,250	\$170,606	\$0	\$0	\$0	\$0	\$0
				BNIA CAP RES.	\$51,714	\$0	\$9,062	\$42,652	\$0	\$0	\$0	\$0	\$0
				TOTAL	\$258,570	\$0	\$45,312	\$213,258	\$0	\$0	\$0	\$0	\$0
AUTOMATIC BAG SORT SYS.-EQUIP./BLDG. AND EMERGENCY GENERATOR VENTILATION	2-2401/2-2439		NI	PFC	\$26,939,300	\$25,714,802	\$224,498	\$1,000,000	\$0	\$0	\$0	\$0	\$0
ENGINEERED WETLAND GLYCOL TREATMENT	2-2395		NI	AIP	\$2,485,351	\$2,377,629	\$80,309	\$27,413	\$0	\$0	\$0	\$0	\$0
				NYS DOT	\$414,449	\$396,486	\$13,392	\$4,571	\$0	\$0	\$0	\$0	\$0
				NYS DEC	\$421,200	\$402,944	\$13,610	\$4,646	\$0	\$0	\$0	\$0	\$0
				PFC (MATCH)	\$414,449	\$396,486	\$13,392	\$4,571	\$0	\$0	\$0	\$0	\$0
				PFC	\$9,863,851	\$9,436,323	\$318,730	\$108,798	\$0	\$0	\$0	\$0	\$0
				TOTAL	\$13,599,300	\$13,009,868	\$439,433	\$150,000	\$0	\$0	\$0	\$0	\$0
GLYCOL TREATMENT NEW CELL PHASE 2	--		NI	FUTURE PFC	\$5,800,000	\$0	\$0	\$400,000	\$5,400,000	\$0	\$0	\$0	\$0
ARFF WATERLINE REPLACEMENT	--		SR	PFC	\$878,371	\$0	\$0	\$0	\$103,432	\$774,939	\$0	\$0	\$0
BNIA CONCOURSE MODIFICATIONS (AND RESTROOM)	2-2464		NI	PFC	\$5,836,000	\$5,325,789	\$410,211	\$100,000	\$0	\$0	\$0	\$0	\$0
K-1 PARKING HARDSTANDS	2-2480		NI	FAA	\$429,225	\$60,884	\$368,341	\$0	\$0	\$0	\$0	\$0	\$0
				NYS DOT	\$71,538	\$10,147	\$61,390	\$0	\$0	\$0	\$0	\$0	\$0
				FUTURE PFC	\$71,538	\$10,147	\$61,390	\$0	\$0	\$0	\$0	\$0	\$0
				TOTAL	\$572,300	\$81,179	\$491,121	\$0	\$0	\$0	\$0	\$0	\$0
LONG TERM LOT B PARKING EXPANSION (PHASE II)	2-2469		NI	BOND	\$8,497,967	\$26,096	\$0	\$0	\$561,367	\$7,910,504	\$0	\$0	\$0
PARKING EXPANSION PHASE III	--		NI	BOND	\$28,940,824	\$0	\$0	\$0	\$0	\$0	\$1,995,000	\$13,472,812	\$13,472,812
CCTV PHASE III	--		NI	TSA	\$1,500,000	\$0	\$0	\$0	\$0	\$0	\$0	\$0	\$1,500,000
				NFTA	\$500,000	\$0	\$0	\$0	\$0	\$0	\$0	\$0	\$500,000
				TOTAL	\$2,000,000	\$0	\$0	\$0	\$0	\$0	\$0	\$0	\$2,000,000
REPLACE PARKING LOT 245 CAYUGA ROAD	--		SR	NFTA	\$706,250	\$0	\$0	\$0	\$77,500	\$628,750	\$0	\$0	\$0

BUFFALO NIAGARA INTERNATIONAL AIRPORT

PROJECT TITLE	PROJECT NUMBER	PRTY CL	JUST. CL	FUND SOURCE	TOTAL PROJECT BUDGET	PROJECT LIFE ACTUAL AS OF 7/19/10	TOTAL FORECASTED SPENDING 7/20/10	FISCAL YEAR 2011/2012	FISCAL YEAR 2012/2013	FISCAL YEAR 2013/2014	FISCAL YEAR 2014/2015	FISCAL YEAR 2015/2016	OUT YEARS
BNIA SECURITY SYSTEM UPGRADE	2-2497		NR	BNIA CAP. RES.	\$455,705	\$405,631	\$50,074	\$0	\$0	\$0	\$0	\$0	\$0
				SPEC COND #7	\$966,995	\$860,739	\$106,256	\$0	\$0	\$0	\$0	\$0	\$0
				TOTAL	\$1,422,700	\$1,266,370	\$156,330	\$0	\$0	\$0	\$0	\$0	\$0
BNIA TERM. FIRE ALARM SYSTEM W/ UPGRADE	2-2479		NR	BNIA CAP. RES.	\$995,000	\$529,561	\$465,439	\$0	\$0	\$0	\$0	\$0	\$0
PARKING GARAGE / TWO TIER ROAD REHAB.	2-2502		SR	FAA	\$1,089,000	\$104,414	\$5,087	\$979,500	\$0	\$0	\$0	\$0	\$0
				NYS DOT	\$181,500	\$17,402	\$848	\$163,250	\$0	\$0	\$0	\$0	\$0
				PFC	\$181,500	\$17,402	\$848	\$163,250	\$0	\$0	\$0	\$0	\$0
				TOTAL	\$1,452,000	\$139,218	\$6,782	\$1,306,000	\$0	\$0	\$0	\$0	\$0
SNOW STORAGE BUILDING	--		NI	FAA	\$8,611,556	\$0	\$0	\$0	\$0	\$0	\$646,271	\$7,965,284	\$0
				NYS DOT	\$1,435,259	\$0	\$0	\$0	\$0	\$0	\$107,712	\$1,327,547	\$0
				PFC	\$1,435,259	\$0	\$0	\$0	\$0	\$0	\$107,712	\$1,327,547	\$0
				TOTAL	\$11,482,074	\$0	\$0	\$0	\$0	\$0	\$861,695	\$10,620,379	\$0
BAGGAGE CLAIM AREA EXPANSION & HVAC RECIRC	--		NI	PFC	\$30,300,000	\$0	\$0	\$0	\$0	\$30,300,000	\$0	\$0	\$0
AFSS BUILDING ROOF REPLACEMENT	--		SR	BNIA CAP. RES.	\$606,366	\$0	\$0	\$69,884	\$536,482	\$0	\$0	\$0	\$0
FUEL FARM ROOF REPLACEMENT	--		SR	BNIA CAP. RES.	\$141,496	\$0	\$0	\$23,642	\$117,854	\$0	\$0	\$0	\$0
AFSS HVAC	--		SR	BNIA CAP. RES.	\$515,742	\$0	\$0	\$61,023	\$454,719	\$0	\$0	\$0	\$0
ENTRANCE FOUNTAIN REHAB.	--		SR	BNIA CAP. RES.	\$422,426	\$0	\$0	\$51,203	\$371,223	\$0	\$0	\$0	\$0
REPLACE REVOLVING DOORS WITH SLIDING DOORS	2-2522		SR	FAA	\$1,413,160	\$0	\$0	\$0	\$97,460	\$1,315,700	\$0	\$0	\$0
				NYS DOT	\$235,527	\$0	\$0	\$0	\$16,243	\$219,283	\$0	\$0	\$0
				PFC	\$235,527	\$0	\$0	\$0	\$16,243	\$219,283	\$0	\$0	\$0
				TOTAL	\$1,884,213	\$0	\$0	\$0	\$129,946	\$1,754,267	\$0	\$0	\$0
CCR ELECTRICAL DISTR. UPGRADE	2-2512		SR	FAA	\$463,560	\$5,342	\$458,219	\$0	\$0	\$0	\$0	\$0	\$0
				NYS DOT	\$77,260	\$890	\$76,370	\$0	\$0	\$0	\$0	\$0	\$0
				PFC	\$77,260	\$890	\$76,370	\$0	\$0	\$0	\$0	\$0	\$0
				TOTAL	\$618,080	\$7,122	\$610,958	\$0	\$0	\$0	\$0	\$0	\$0
BNIA AIRFIELD /FUEL FARM / GARAGE													
UPGRADE CATHODIC PROTECTION	2-2465		SR	BNIA CAP RES	\$386,947	\$20,536	\$38,067	\$328,344	\$0	\$0	\$0	\$0	\$0
ULTRA LOW SULFUR DIESEL TANK INSTALLATION	--	M	SR	FAA	\$284,387	\$0	\$0	\$0	\$35,738	\$248,650	\$0	\$0	\$0
				NYS DOT	\$47,398	\$0	\$0	\$0	\$5,956	\$41,442	\$0	\$0	\$0
				PFC	\$47,398	\$0	\$0	\$0	\$5,956	\$41,442	\$0	\$0	\$0
				TOTAL	\$379,183	\$0	\$0	\$0	\$47,650	\$331,533	\$0	\$0	\$0
HEARING PROTECTION / RADIO REPLACEMENT	2-2494		NI	BNIA CAP. RES.	\$58,000	\$0	\$0	\$0	\$0	\$0	\$0	\$0	\$58,000
SOLAR WALL MAINTENANCE GARAGE	--		NI	PENDING GRANT	\$175,000	\$0	\$0	\$0	\$175,000	\$0	\$0	\$0	\$0

BUFFALO NIAGARA INTERNATIONAL AIRPORT

PROJECT TITLE	PROJECT NUMBER	PRTY CL	JUST. CL	FUND SOURCE	TOTAL PROJECT BUDGET	PROJECT LIFE	TOTAL	FISCAL	FISCAL	FISCAL	FISCAL	FISCAL	OUT YEARS
						ACTUAL AS OF 7/19/10	FORECASTED SPENDING 7/20/10	YEAR 2011/2012	YEAR 2012/2013	YEAR 2013/2014	YEAR 2014/2015	YEAR 2015/2016	
LIQUID CHEMICAL STORAGE FACILITY	--		NI	FAA	\$37,500	\$0	\$0	\$0	\$0	\$37,500	\$0	\$0	\$0
				NYSDOT	\$6,250	\$0	\$0	\$0	\$0	\$6,250	\$0	\$0	\$0
				PFC	\$6,250	\$0	\$0	\$0	\$0	\$6,250	\$0	\$0	\$0
				TOTAL	\$50,000	\$0	\$0	\$0	\$0	\$50,000	\$0	\$0	\$0
WILDLIFE HAZARD ASSESSMENT	2-2520	M	SR	FAA	\$59,981	\$0	\$22,493	\$37,489	\$0	\$0	\$0	\$0	\$0
				NYSDOT	\$9,997	\$0	\$3,749	\$6,248	\$0	\$0	\$0	\$0	\$0
				FUTURE PFC	\$9,997	\$0	\$3,749	\$6,248	\$0	\$0	\$0	\$0	\$0
				TOTAL	\$79,975	\$0	\$29,990	\$49,985	\$0	\$0	\$0	\$0	\$0
SALT BARN	--		SR	FUTURE PFC	\$529,071	\$0	\$0	\$0	\$70,539	\$458,532	\$0	\$0	\$0
SPREADER - NEW	--		NR	FUTURE PFC	\$369,000	\$0	\$0	\$369,000	\$0	\$0	\$0	\$0	\$0
RAMP SWEEPERS	--		NR	NFTA	\$156,000	\$0	\$0	\$0	\$0	\$156,000	\$0	\$0	\$0
REPLACE FRICTION TESTER	2-2516		NR	PFC	\$178,467	\$0	\$178,467	\$0	\$0	\$0	\$0	\$0	\$0
REPLACE AIRFIELD PICKUP TRUCKS	2-2493		NR	BNIA CAP RES	\$175,000	\$0	\$0	\$0	\$35,000	\$35,000	\$35,000	\$35,000	\$35,000
STREET SWEEPER (1 REPLACEMENT)	--		NR	BNIA CAP RES	\$260,000	\$0	\$0	\$260,000	\$0	\$0	\$0	\$0	\$0
GEOSPATIAL INFO. SYSTEM (GIS)	--		NI	NFTA	\$1,700,000	\$0	\$0	\$0	\$0	\$0	\$1,000,000	\$700,000	\$0
AUTOMATIC FOD DETECTION SCAN SYSTEM	--		NI	PFC	\$2,500,000	\$0	\$0	\$0	\$0	\$0	\$0	\$0	\$2,500,000
AUTOMATED AIRFIELD REPORTING	--		NI	NFTA	\$2,200,000	\$0	\$0	\$0	\$0	\$0	\$0	\$0	\$2,200,000
BOBCAT WITH ATTACHMENT	--		NR	BNIA CAP RES	\$40,000	\$0	\$0	\$0	\$40,000	\$0	\$0	\$0	\$0
GLYCOL RECOVERY VEHICLE REPLACEMENT (2)	--		NR	FUTURE PFC	\$500,000	\$0	\$0	\$0	\$250,000	\$0	\$250,000	\$0	\$0
NEW LOADER	--		NI	PFC	\$263,000	\$0	\$0	\$263,000	\$0	\$0	\$0	\$0	\$0
BATWING REPLACEMENT	--		NR	NFTA	\$86,600	\$0	\$0	\$0	\$0	\$86,600	\$0	\$0	\$0
TRUCK FOR LIQUID CHEMICAL APPLICATION	--		NI	FUTURE PFC	\$250,000	\$0	\$0	\$0	\$0	\$250,000	\$0	\$0	\$0
PORTABLE SNOW MELTER	--		NI	FUTURE PFC	\$220,000	\$0	\$0	\$0	\$0	\$0	\$220,000	\$0	\$0
BNIA AIRCRAFT FIRE RESCUE													
ARFF BUILDING WINDOW REPLACEMENT	2-2459		SR	BNIA CAP. RES.	\$140,816	\$6,201	\$14,449	\$120,166	\$0	\$0	\$0	\$0	\$0
ARFF BUILDING -INSTALL NON-SLIP FLOORING	--		SR	NFTA	\$25,000	\$0	\$0	\$0	\$25,000	\$0	\$0	\$0	\$0
ARFF RADIANT HEAT FOR APPARATUS ROOM	--		NI	NFTA	\$57,200	\$0	\$0	\$0	\$57,200	\$0	\$0	\$0	\$0
ARFF PORTABLE RADIO REPLACEMENT	--		NR	BNIA CAP. RES.	\$10,000	\$0	\$0	\$10,000	\$0	\$0	\$0	\$0	\$0
ARFF TRUCK	--		NR	PFC	\$979,000	\$0	\$0	\$0	\$979,000	\$0	\$0	\$0	\$0
ARFF MINI PUMP REPLACEMENT	--		NR	PFC	\$100,000	\$0	\$0	\$100,000	\$0	\$0	\$0	\$0	\$0
ARFF JAWS OF LIFE / TOOLS	--		NI	BNIA CAP. RES.	\$10,000	\$0	\$0	\$10,000	\$0	\$0	\$0	\$0	\$0
ARFF - FUEL FARM MONITORS	--		NI	BNIA CAP. RES.	\$50,000	\$0	\$0	\$0	\$50,000	\$0	\$0	\$0	\$0
ARFF - REPLACE CARPETING	--		NR	BNIA CAP. RES.	\$10,000	\$0	\$0	\$10,000	\$0	\$0	\$0	\$0	\$0
ARFF - AIRCRAFT STABILIZATION BAGS	--		NI	BNIA CAP. RES.	\$7,500	\$0	\$0	\$0	\$0	\$7,500	\$0	\$0	\$0
ARFF - THERMAL PORTABLE CAMERA	--		NI	BNIA CAP. RES.	\$5,000	\$0	\$0	\$5,000	\$0	\$0	\$0	\$0	\$0
ARFF - (5) MOBILE RADIOS (400 Mghz)	--		NR	BNIA CAP. RES.	\$7,750	\$0	\$0	\$7,750	\$0	\$0	\$0	\$0	\$0
ARFF FOAM TRAILER	--		NI	BNIA CAP. RES.	\$30,000	\$0	\$0	\$0	\$30,000	\$0	\$0	\$0	\$0
ARFF DEFIBULATOR	2-2518		NI	BNIA CAP. RES.	\$3,000	\$0	\$3,000	\$0	\$0	\$0	\$0	\$0	\$0

BUFFALO NIAGARA INTERNATIONAL AIRPORT

PROJECT TITLE	PROJECT NUMBER	PRTY CL	JUST. CL	FUND SOURCE	TOTAL PROJECT BUDGET	PROJECT LIFE ACTUAL AS OF 7/19/10	TOTAL FORECASTED SPENDING 7/20/10	FISCAL YEAR 2011/2012	FISCAL YEAR 2012/2013	FISCAL YEAR 2013/2014	FISCAL YEAR 2014/2015	FISCAL YEAR 2015/2016	OUT YEARS
BNIA TERMINAL													
UPGRADE FIDS SYSTEM	2-2475		SR	BNIA CAP. RES.	\$163,982	\$0	\$5,000	\$35,000	\$35,000	\$35,000	\$35,000	\$18,982	\$0
REPLACE TERMINAL FLOOR CLEANING EQUIP.													
FLOOR SCRUBBER RELACEMENT	2-2489		NR	BNIA CAP. RES.	\$42,000	\$0	\$0	\$42,000	\$0	\$0	\$0	\$0	\$0
PROPANE BARNIGNER	--		NR	BNIA CAP. RES.	\$3,700	\$0	\$0	\$3,700	\$0	\$0	\$0	\$0	\$0
WALK BEHIND SCRUBBER	--		NR	BNIA CAP. RES.	\$5,500	\$0	\$0	\$5,500	\$0	\$0	\$0	\$0	\$0
SMOKING BOOTHS (2)	--		NI	BNIA CAP. RES.	\$30,000	\$0	\$0	\$30,000	\$0	\$0	\$0	\$0	\$0
WI FI EQUIPMENT	--		NR	NFTA	\$140,000	\$0	\$140,000	\$0	\$0	\$0	\$0	\$0	\$0
ANTI-GLARE FILM TO TERMINAL FRONTAGE GLASS	--		NR	BNIA CAP. RES.	\$106,240	\$0	\$0	\$106,240	\$0	\$0	\$0	\$0	\$0
BNIA FMD SPONSORED													
REPLACE FMD PICKUP/UTILITY TRUCK	2-2492		NR	BNIA CAP RES	\$38,000	\$0	\$0	\$38,000	\$0	\$0	\$0	\$0	\$0
REPLACE FMD PICKUP/UTILITY TRUCK	--		NR	NFTA	\$146,000	\$0	\$0	\$0	\$35,000	\$36,000	\$37,000	\$38,000	\$0
FMD MOVE TO TERMINAL	--		NI	NFTA	\$260,000	\$0	\$0	\$0	\$0	\$260,000	\$0	\$0	\$0
MINI JETTER	--		NI	BNIA CAP RES	\$5,000	\$0	\$0	\$5,000	\$0	\$0	\$0	\$0	\$0
LAPTOP FOR HVAC	--		NI	BNIA CAP RES	\$3,000	\$0	\$0	\$3,000	\$0	\$0	\$0	\$0	\$0
HYDRAULIC PRESS	--		NI	BNIA CAP RES	\$3,000	\$0	\$0	\$3,000	\$0	\$0	\$0	\$0	\$0
BOOSTER PUMP	--		NI	BNIA CAP RES	\$20,000	\$0	\$0	\$20,000	\$0	\$0	\$0	\$0	\$0
AFSS RENOVATIONS													
	2-2506		NI	BNIA CAP. RES.	\$186,000	\$68,135	\$117,865	\$0	\$0	\$0	\$0	\$0	\$0
				DHS	\$35,000	\$0	\$35,000	\$0	\$0	\$0	\$0	\$0	\$0
				TAPD RES.	\$100,000	\$100,000	\$0	\$0	\$0	\$0	\$0	\$0	\$0
				TOTAL	\$321,000	\$168,135	\$152,865	\$0	\$0	\$0	\$0	\$0	\$0
BNIA PARKING													
REPLACE SHUTTLE BUSES FYE 15-16	--		NR	FUTURE PFC	\$690,459	\$0	\$0	\$0	\$0	\$0	\$336,809	\$353,650	\$0
REPLACE SHUTTLE BUSES FYE 11 - 14	2-2517		NR	PFC	\$1,228,104	\$0	\$595,907	\$0	\$311,427	\$320,770	\$0	\$0	\$0
SALTER FOR PARKING GARAGE	--		NI	BNIA CAP. RES.	\$5,000	\$0	\$5,000	\$0	\$0	\$0	\$0	\$0	\$0
RADIOS / MOBILES FOR PARKING SHUTTLES	2-2521		NI	BNIA CAP. RES.	\$22,000	\$0	\$22,000	\$0	\$0	\$0	\$0	\$0	\$0
PICK-UP TRUCK REPLACEMENT	--		NR	BNIA CAP. RES.	\$43,500	\$0	\$0	\$19,500	\$24,000	\$0	\$0	\$0	\$0
SHUTTLE BUS CAMERA REPLACEMENT	--		NR	BNIA CAP. RES.	\$26,000	\$0	\$0	\$26,000	\$0	\$0	\$0	\$0	\$0
REVENUE CONTROL EQUIP. CABINET REPLACE.	--		NR	BNIA CAP. RES.	\$102,000	\$0	\$0	\$22,000	\$20,000	\$20,000	\$20,000	\$20,000	\$0
REPLACE RWPV HEADS (READ/WRITE/PRINT/VALIDATE)	--		NR	BNIA CAP. RES.	\$184,000	\$0	\$0	\$24,000	\$40,000	\$40,000	\$40,000	\$40,000	\$0
REPLACE SHUTTLE SHELTERS (5 PER YEAR)	--		NR	BNIA CAP. RES.	\$180,000	\$0	\$0	\$0	\$45,000	\$45,000	\$45,000	\$45,000	\$0

BUFFALO NIAGARA INTERNATIONAL AIRPORT

PROJECT TITLE	PROJECT NUMBER	PRTY CL	JUST. CL	FUND SOURCE	TOTAL PROJECT BUDGET	PROJECT LIFE ACTUAL AS OF 7/19/10	TOTAL FORECASTED SPENDING 7/20/10	FISCAL YEAR 2011/2012	FISCAL YEAR 2012/2013	FISCAL YEAR 2013/2014	FISCAL YEAR 2014/2015	FISCAL YEAR 2015/2016	OUT YEARS
BNIA OTHER													
TELECOMMUNICATION UPGRADE	2-2519		NI	ADF	\$120,331	\$0	\$0	\$120,331	\$0	\$0	\$0	\$0	\$0
				NFTA	\$73,000	\$0	\$73,000	\$0	\$0	\$0	\$0	\$0	\$0
				TOTAL	\$193,331	\$0	\$73,000	\$120,331	\$0	\$0	\$0	\$0	\$0
PFC PROGRAM PLANNING & ADMIN.	2-2309		NR	PFC	\$413,425	\$260,027	\$52,770	\$45,015	\$55,613	\$0	\$0	\$0	\$0

FAA	\$118,825,929	\$43,405,635	\$4,881,999	\$6,227,547	\$5,093,093	\$8,147,746	\$7,802,371	\$21,280,237	\$21,987,300
NYS DOT	\$17,822,441	\$6,911,276	\$689,892	\$845,424	\$651,853	\$1,122,212	\$1,051,371	\$3,285,048	\$3,265,365
NFTA	\$6,050,050	\$0	\$213,000	\$0	\$194,700	\$1,167,350	\$1,037,000	\$738,000	\$2,700,000
ADF	\$120,331	\$0	\$0	\$120,331	\$0	\$0	\$0	\$0	\$0
BNIA CAP. RES	\$5,801,384	\$1,030,064	\$729,956	\$1,632,604	\$1,799,278	\$182,500	\$175,000	\$158,982	\$93,000
SPEC COND #7	\$966,995	\$860,739	\$106,256	\$0	\$0	\$0	\$0	\$0	\$0
PFC	\$92,572,363	\$44,009,504	\$2,725,041	\$2,371,278	\$2,075,700	\$32,489,880	\$854,783	\$2,280,812	\$5,765,365
FUTURE PFC	\$9,881,947	\$14,335	\$168,205	\$855,388	\$5,746,164	\$736,573	\$1,003,397	\$1,357,886	\$0
AIP	\$2,485,351	\$2,377,629	\$80,309	\$27,413	\$0	\$0	\$0	\$0	\$0
PFC (MATCH)	\$4,706,182	\$4,688,218	\$13,393	\$4,571	\$0	\$0	\$0	\$0	\$0
BOND	\$37,438,591	\$26,096	\$0	\$0	\$561,367	\$7,910,504	\$1,995,000	\$13,472,812	\$13,472,812
TSA	\$1,500,000	\$0	\$0	\$0	\$0	\$0	\$0	\$0	\$1,500,000
NYSDEC	\$421,200	\$402,944	\$13,610	\$4,646	\$0	\$0	\$0	\$0	\$0
PENDING GRANT	\$381,856	\$0	\$36,250	\$170,606	\$175,000	\$0	\$0	\$0	\$0
DHS	\$35,000	\$0	\$35,000	\$0	\$0	\$0	\$0	\$0	\$0
TAPD RES.	\$100,000	\$100,000	\$0	\$0	\$0	\$0	\$0	\$0	\$0
TOTAL	\$299,109,620	\$103,826,440	\$9,692,910	\$12,259,808	\$16,297,155	\$51,756,766	\$13,918,922	\$42,573,777	\$48,783,842

NIAGARA FALLS INTERNATIONAL AIRPORT

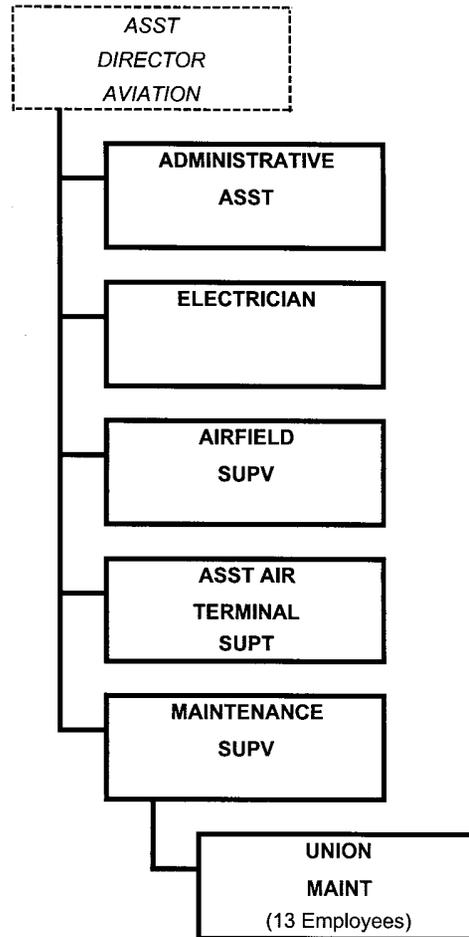

TOTAL EMPLOYEES 18

NFIA
2010/11 ANNUAL BUDGET
VS
2011/12 ANNUAL BUDGET

	FY 09-10	FY 10-11	FY 11-12	VARIANCE	%
	ACTUAL	BUDGET	BUDGET		
OPERATING REVENUES					
Airport Fees & Services	32,012	38,180	48,750	10,570	27.7%
Rental Income	114,690	166,565	141,267	-25,298	-15.2%
Concessions/Commissions	113,478	363,703	853,714	490,011	134.7%
Retail Sales	0	0	0	0	n/a
Resales & Rebillings	16,473	16,476	16,476	0	0.0%
Other Operating Revenues	<u>144,150</u>	<u>45,000</u>	<u>87,000</u>	<u>42,000</u>	<u>93.3%</u>
TOTAL OPER REVENUES	420,803	629,924	1,147,207	517,283	82.1%
OPERATING EXPENSES (Excl. Depr.)					
Personnel Services	1,041,403	1,144,107	1,445,919	301,812	26.4%
Maintenance & Repairs	578,187	842,207	900,060	57,853	6.9%
Utilities	208,456	367,938	383,265	15,327	4.2%
Insurance & Injuries	87,323	105,085	108,421	3,336	3.2%
Safety & Security	96,644	113,300	339,000	225,700	199.2%
General Business/Other	333,536	486,337	588,464	102,127	21.0%
Admin Cost Reallocation	675,608	703,726	654,842	-48,884	-6.9%
Costs Transferred to Cap'l Proj	0	0	0	0	n/a
Inter Division Reimbursement	<u>-2,983</u>	<u>0</u>	<u>0</u>	<u>0</u>	<u>n/a</u>
TOTAL OPER EXPENSES	<u>3,018,174</u>	<u>3,762,700</u>	<u>4,419,971</u>	<u>657,271</u>	<u>17.5%</u>
OPERATING INC/(LOSS)	-2,597,371	-3,132,776	-3,272,764	-139,988	4.5%
NON-OPERATING ITEMS					
Debt Service	-539,666	-2,180,160	-2,092,371	87,789	-4.0%
BNIA Contr (Excluding Debt Svc)	1,305,510	1,653,313	1,670,091	16,778	1.0%
BNIA Contribution - Debt Svc	<u>539,666</u>	<u>2,180,160</u>	<u>2,092,371</u>	<u>-87,789</u>	<u>-4.0%</u>
TOTAL NON-OPER ITEMS	<u>1,305,510</u>	<u>1,653,313</u>	<u>1,670,091</u>	<u>16,778</u>	<u>1.0%</u>
NET INCOME/(LOSS)	-1,291,861	-1,479,463	-1,602,673	-123,211	8.3%
LESS: DIRECT CAPITAL	720,325	228,695	0	-228,695	-100.0%
LESS: INDIRECT CAPITAL	<u>30,118</u>	<u>47,004</u>	<u>67,417</u>	<u>20,413</u>	<u>43.4%</u>
NET SURPLUS/(DEFICIT)	<u>-2,042,303</u>	<u>-1,755,162</u>	<u>-1,670,091</u>	<u>85,071</u>	<u>-4.8%</u>

NIAGARA FALLS INTERNATIONAL AIRPORT

PERFORMANCE INDICATORS

DESCRIPTION	FYE 10 <u>Actual</u>	FYE 11 <u>Original Budget</u>	FYE 11 <u>Current Estimate</u>	FYE 12 <u>Budget</u>
Niagara Falls International Airport (NFIA) is a joint-use military/general aviation airport that provides commercial passenger and air cargo service. NFIA has been designated by the Federal Aviation Administration as a reliever airport to attract general aviation traffic from Buffalo Niagara International Airport (BNIA). NFIA has a positive impact on BNIA's limited airside capacity, which enhances the efficiency and safety of BNIA airside operations.				
NFIA, which is situated on 1,100 acres of property, has a 9,800 foot main runway as well as two general aviation runways (5,063 and 4,030 feet). A newly constructed state of the art 69,000 square foot terminal was opened in December 2009. During FY2012, four scheduled air carrier / charter operators are anticipated to operate handling an estimated 190,000 passengers. In addition to the main terminal, NFIA has a general aviation complex consisting of hangars, tie downs, a customer service area and a pilot's lounge. A private Fixed Base Operator, FBO, offers full aviation services to the aviation public.				
FAA Regulations	100%	100%	100%	100%
Charter Operations	2	10	6	6
Scheduled Carrier Operations	502	410	687	700
General Aviation Operations	16,716	22,500	14,064	14,100
Total Passengers	49,503	54,000	74,982	190,930

PROGRAM AND SERVICE OBJECTIVES

- Continue the aggressive marketing approach to capitalize on Air Cargo and Charter opportunities in the most cost efficient operating manner.
- Work closely with the FBO to assure the performance of contracted services and the marketing program for the airport to increase business and revenue.
- Continue to market the new NFIA terminal to potential air service providers and concessionaires to provide quality customer service and improve operating profits.
- Continue to increase satisfaction and customer service and enhance public and customer perception of the airport.
- Continue to promote and maintain a safe working environment for NFIA employees with the goal of no lost time incidents and no workers' compensation expense.

NIAGARA FRONTIER TRANSPORTATION AUTHORITY
(ACCOUNTCO, ACCOUNTUNIT, ACCOUNT)
BUDGET WORKSHEETS - Fiscal Year 2011-12

Company 1 Niagara Frontier Transportation Authority
Division 03 NIAGARA FALLS INT'L AIRPORT
Department 0099 ADMINSTRATIVE AND GENERAL

Account	Description	2009-10 Actual	2010-11 Budget	2010-11 Sept. YTD Actual	2011-12 Req Budget	VARIANCE From Budget
499	OTHER OPERATING REVENUES	144,130-	35,000-	94,880-	82,000-	47,000-
	TOTAL REVENUES	144,130-	35,000-	94,880-	82,000-	47,000-

NIAGARA FRONTIER TRANSPORTATION AUTHORITY
(ACCOUNTCO, ACCOUNTUNIT, ACCOUNT)
BUDGET WORKSHEETS - Fiscal Year 2011-12

Company 1 Niagara Frontier Transportation Authority
Division 03 NIAGARA FALLS INT'L AIRPORT
Department 0099 ADMINSTRATIVE AND GENERAL

Account	Description	2009-10 Actual	2010-11 Budget	2010-11 Sept. YTD Actual	2011-12 Req Budget	VARIANCE From Budget
510	EMPLOYEE SALARIES	84,893	80,634	55,249	81,412	778
515	EMPLOYEE BENEFITS	19,318	21,874	16,033	23,093	1,219
534	TELEPHONE	4,009	9,308	5,118	5,003	4,305-
541	INSURANCE	87,590	105,085	70,768	108,421	3,336
542	CLAIM LOSSES	268-		58,895		
571	CONSULTANTS/OUTSIDE SERVICES	24,728	105,000	69,999	60,000	45,000-
574	TAXES AND ASSESSMENTS	3,440	3,500	3,440	3,440	60-
575	PRINTING & ADVERTISING	199,714	217,000	172,746	227,600	10,600
576	EMPLOYEE TRAVEL	9,388	30,000	14,117	30,000	
578	POSTAGE	219	199	161	200	1
580	GENERAL OFFICE	14,976	11,500	5,999	8,500	3,000-
TOTAL	EXPENSES	448,007	584,100	472,525	547,669	36,431-

QB201 Date 03/24/11
Time 08:34

Niagara Frontier Transportation Authority
Print Personnel Budget Worksheets 2010 - 2011

03 NIAGARA FALLS INT'L AIRPORT
99 ADMINSTRATIVE AND GENERAL

EMPLOYEE GROUP: PB-ALL

Job Description	Grade/Step		Base Salary	Increase Amount	Longevity Amount	Scheduled Amount
-----	-----	-----	-----	-----	-----	-----
ADMINISTRATIVE ASSISTA	4	6	37,299	1,887	1,100	40,286
UNION Totals		1	37,299	1,887	1,100	40,286
Department Totals		1	37,299	1,887	1,100	40,286

NIAGARA FRONTIER TRANSPORTATION AUTHORITY
(ACCOUNTCO, ACCOUNTUNIT, ACCOUNT)
BUDGET WORKSHEETS - Fiscal Year 2011-12

Company 1 Niagara Frontier Transportation Authority
Division 03 NIAGARA FALLS INT'L AIRPORT
Department 0219 LANDING AREA

Account	Description	2009-10 Actual	2010-11 Budget	2010-11 Sept. YTD Actual	2011-12 Req Budget	VARIANCE From Budget
401	LANDING FEES	32,012-	38,180-	29,079-	48,750-	10,570-
439	OTHER RENTALS	61,221-	67,299-	68,148-	71,276-	3,977-
442	COMMISSIONS	112,718-	123,702-	100,396-	127,414-	3,712-
	TOTAL REVENUES	205,951-	229,181-	197,623-	247,440-	18,259-

NIAGARA FRONTIER TRANSPORTATION AUTHORITY
(ACCOUNTCO, ACCOUNTUNIT, ACCOUNT)
BUDGET WORKSHEETS - Fiscal Year 2011-12

Company 1 Niagara Frontier Transportation Authority
Division 03 NIAGARA FALLS INT'L AIRPORT
Department 0219 LANDING AREA

Account	Description	2009-10 Actual	2010-11 Budget	2010-11 Sept. YTD Actual	2011-12 Req Budget	VARIANCE From Budget
510	EMPLOYEE SALARIES	427,742	553,007	340,087	652,114	99,107
515	EMPLOYEE BENEFITS	167,137	244,367	156,137	301,247	56,880
520	MAINTENANCE AND REPAIRS	344,276	407,747	279,715	468,750	61,003
527	ENVIRONMENTAL	13,396	30,999	15,504	46,315	15,316
530	GROUNDS & LANDSCAPING	2,397	3,395	1,004	3,700	305
531	ELECTRIC POWER	2,242	2,705	1,646	3,102	397
534	TELEPHONE	1,174	845	855	1,112	267
571	CONSULTANTS/OUTSIDE SERVICES	46,712	25,000	21,305	20,000	5,000-
577	EMPLOYEE TRAINING	1,742	4,339	3,123	1,742	2,597-
592	DIVISION OPERATIONS	2,983-				
TOTAL	EXPENSES	1,003,835	1,272,404	819,376	1,498,082	225,678

03 NIAGARA FALLS INT'L AIRPORT
0219 LANDING AREA

EMPLOYEE GROUP: PB-ALL

Job Description	Grade/Step		Base Salary	Increase Amount	Longevity Amount	Scheduled Amount
MAINTENANCE SUPERVISOR	3	5	59,449	3,317	1,800	64,566
AIRFIELD SUPERVISOR	3	2	54,277	4,394	700	59,371
ELECTRICIAN	A	6	49,020		1,800	50,820
SR. AIRPORT ATTENDANT	A	6	47,980		1,800	49,780
SR. AIRPORT ATTENDANT	A	6	47,980		1,400	49,380
SR. AIRPORT ATTENDANT	A	6	47,980		1,400	49,380
SR. AIRPORT ATTENDANT	A	6	47,980		1,400	49,380
SR. AIRPORT ATTENDANT	A	6	47,980		1,400	49,380
SR. AIRPORT ATTENDANT	A	6	47,980		1,400	49,380
SR. AIRPORT ATTENDANT	A	6	47,980		1,100	49,080
FIELDPERSON	B	4	36,762	1,749		38,511
UNION Totals	11		535,368	9,460	14,200	559,028
Department Totals	11		535,368	9,460	14,200	559,028

NIAGARA FRONTIER TRANSPORTATION AUTHORITY
(ACCOUNTCO, ACCOUNTUNIT, ACCOUNT)
BUDGET WORKSHEETS - Fiscal Year 2011-12

Company 1 Niagara Frontier Transportation Authority
Division 03 NIAGARA FALLS INT'L AIRPORT
Department 0245 TERMINAL BUILDING

Account	Description	2009-10 Actual	2010-11 Budget	2010-11 Sept. YTD Actual	2011-12 Req Budget	VARIANCE From Budget
431	BUILDING SPACE	37,932-	55,000-	1,199-	2,400-	52,600
462	REBILLINGS	16,477-			16,476-	16,476-
494	ADVERTISING REVENUES	20-				
TOTAL REVENUES		54,429-	55,000-	1,199-	18,876-	36,124

NIAGARA FRONTIER TRANSPORTATION AUTHORITY
(ACCOUNTCO, ACCOUNTUNIT, ACCOUNT)
BUDGET WORKSHEETS - Fiscal Year 2011-12

Company 1 Niagara Frontier Transportation Authority
Division 03 NIAGARA FALLS INT'L AIRPORT
Department 0245 TERMINAL BUILDING

Account	Description	2009-10 Actual	2010-11 Budget	2010-11 Sept. YTD Actual	2011-12 Req Budget	VARIANCE From Budget
510	EMPLOYEE SALARIES	130,828		33,953		
515	EMPLOYEE BENEFITS	50,924		16,300		
520	MAINTENANCE AND REPAIRS	95,563	67,000	6,641	39,500	27,500-
530	GROUNDS & LANDSCAPING	1,598				
531	ELECTRIC POWER	57,086	11,212	33,057	56,640	45,428
532	GAS	45,183	24,103	17,148	45,549	21,446
533	WATER	11,799	412	25,756	40,365	39,953
534	TELEPHONE	305				
551	ARMED GUARDS	96,651				
571	CONSULTANTS/OUTSIDE SERVICES			11,195		
574	TAXES AND ASSESSMENTS	396	499			499-
TOTAL	EXPENSES	490,333	103,226	144,050	182,054	78,828

NIAGARA FRONTIER TRANSPORTATION AUTHORITY
(ACCOUNTCO, ACCOUNTUNIT, ACCOUNT)
BUDGET WORKSHEETS - Fiscal Year 2011-12

Company 1 Niagara Frontier Transportation Authority
Division 03 NIAGARA FALLS INT'L AIRPORT
Department 0246 NFIA New Terminal

Account	Description	2009-10 Actual	2010-11 Budget	2010-11 Sept. YTD Actual	2011-12 Req Budget	VARIANCE From Budget
431	BUILDING SPACE	302-	9,590-	7,020-	13,776-	4,186-
433	GROUND RENTALS		19,776-	28,352-	38,610-	18,834-
441	CONCESSIONS	757-	240,000-	2,751-	4,800-	235,200
442	COMMISSIONS			1,732-	1,500-	1,500-
462	REBILLINGS		16,476-	13,943-		16,476
494	ADVERTISING REVENUES		10,000-		5,000-	5,000
TOTAL	REVENUES	1,059-	295,842-	53,798-	63,686-	232,156

NIAGARA FRONTIER TRANSPORTATION AUTHORITY
(ACCOUNTCO, ACCOUNTUNIT, ACCOUNT)
BUDGET WORKSHEETS - Fiscal Year 2011-12

Company 1 Niagara Frontier Transportation Authority
Division 03 NIAGARA FALLS INT'L AIRPORT
Department 0246 NFIA New Terminal

Account	Description	2009-10 Actual	2010-11 Budget	2010-11 Sept. YTD Actual	2011-12 Req Budget	VARIANCE From Budget
510	EMPLOYEE SALARIES		50,615	77,218	146,447	95,832
515	EMPLOYEE BENEFITS		22,685	35,084	70,509	47,824
520	MAINTENANCE AND REPAIRS	54,009	93,750	81,693	199,120	105,370
526	JANITORIAL AND LAUNDRY	2,000	125,000	11,313	30,812	94,188-
530	GROUNDS & LANDSCAPING	1,066	3,000	2,508	3,000	
531	ELECTRIC POWER	43,181	181,390	123,879	160,199	21,191-
532	GAS	20,832	78,307	10,685	32,039	46,268-
533	WATER	338	5,500	689	896	4,604-
534	TELEPHONE	13,946	44,973	20,122	27,566	17,407-
551	ARMED GUARDS		113,300	154,705	300,000	186,700
554	TRAFFIC CONTROL				39,000	39,000
571	CONSULTANTS/OUTSIDE SERVICES	1,187				
574	TAXES AND ASSESSMENTS	29,700	89,000	29,700-		89,000-
580	GENERAL OFFICE	970		3,216	5,000	5,000
TOTAL	EXPENSES	167,229	807,520	491,412	1,014,588	207,068

QB201 Date 03/24/11
Time 08:34

Niagara Frontier Transportation Authority
Print Personnel Budget Worksheets 2010 - 2011

Page 12

03 NIAGARA FALLS INT'L AIRPORT
0246 NFIA New Terminal

EMPLOYEE GROUP: PB-ALL

Job Description	Grade/Step	Base Salary	Increase Amount	Longevity Amount	Scheduled Amount
ASST. AIR TERM. SUPERI	13	65,000			65,000
NON-REP Totals	1	65,000			65,000
CUSTODIAN II	F 6	27,787		700	28,487
CUSTODIAN	F 3	23,465	1,004		24,469
CUSTODIAN II	F 3	23,466	1,003		24,469
UNION Totals	3	74,718	2,007	700	77,425
Department Totals	4	139,718	2,007	700	142,425

QB204 Date 03/23/11
Time 14:17

NIAGARA FRONTIER TRANSPORTATION AUTHORITY
(ACCOUNTCO, ACCOUNTUNIT, ACCOUNT)
BUDGET WORKSHEETS - Fiscal Year 2011-12

Page 31
CREDITS = (-)
DEBITS = (+)

Company 1 Niagara Frontier Transportation Authority
Division 03 NIAGARA FALLS INT'L AIRPORT
Department 0269 NET LEASED AREA

Account	Description	2009-10 Actual	2010-11 Budget	2010-11 Sept. YTD Actual	2011-12 Req Budget	VARIANCE From Budget
433	GROUND RENTALS	8,400-	8,400-	6,300-	8,575-	175-
	TOTAL REVENUES	8,400-	8,400-	6,300-	8,575-	175-

NIAGARA FRONTIER TRANSPORTATION AUTHORITY
(ACCOUNTCO, ACCOUNTUNIT, ACCOUNT)
BUDGET WORKSHEETS - Fiscal Year 2011-12

Company 1 Niagara Frontier Transportation Authority
Division 03 NIAGARA FALLS INT'L AIRPORT
Department 0271 MAINTENANCE FACILITIES

Account	Description	2009-10 Actual	2010-11 Budget	2010-11 Sept. YTD Actual	2011-12 Req Budget	VARIANCE From Budget
510	EMPLOYEE SALARIES	115,215	117,632	91,513	116,155	1,477-
515	EMPLOYEE BENEFITS	45,324	53,287	42,409	54,942	1,655
520	MAINTENANCE AND REPAIRS	2,301	15,498	8,149	8,600	6,898-
524	AUTOMOTIVE	61,572	95,814	46,549	87,888	7,926-
531	ELECTRIC POWER	8,358	9,182	7,068	10,794	1,612
577	EMPLOYEE TRAINING			1,343		
580	GENERAL OFFICE	359	300	269	400	100
TOTAL	EXPENSES	233,129	291,713	197,300	278,779	12,934-

03 NIAGARA FALLS INT'L AIRPORT
0271 MAINTENANCE FACILITIES

EMPLOYEE GROUP: PB-ALL

Job Description	Grade/Step	Base Salary	Increase Amount	Longevity Amount	Scheduled Amount
MECHANIC	A 6	49,020		1,400	50,420
MECHANIC	A 6	48,604			48,604
UNION Totals	2	97,624		1,400	99,024
Department Totals	2	97,624		1,400	99,024

NIAGARA FRONTIER TRANSPORTATION AUTHORITY
(ACCOUNTCO, ACCOUNTUNIT, ACCOUNT)
BUDGET WORKSHEETS - Fiscal Year 2011-12

Company 1 Niagara Frontier Transportation Authority
Division 03 NIAGARA FALLS INT'L AIRPORT
Department 0274

Account	Description	2009-10 Actual	2010-11 Budget	2010-11 Sept. YTD Actual	2011-12 Req Budget	VARIANCE From Budget
441	CONCESSIONS				720,000-	720,000-
	TOTAL REVENUES				720,000-	720,000-

NIAGARA FRONTIER TRANSPORTATION AUTHORITY
(ACCOUNTCO, ACCOUNTUNIT, ACCOUNT)
BUDGET WORKSHEETS - Fiscal Year 2011-12

Company 1 Niagara Frontier Transportation Authority
Division 03 NIAGARA FALLS INT'L AIRPORT
Department 0274

Account	Description	2009-10 Actual	2010-11 Budget	2010-11 Sept. YTD Actual	2011-12 Req Budget	VARIANCE From Budget
524	AUTOMOTIVE				12,375	12,375
571	CONSULTANTS/OUTSIDE SERVICES				231,582	231,582
	TOTAL EXPENSES				243,957	243,957

QB204 Date 03/23/11
Time 14:17

NIAGARA FRONTIER TRANSPORTATION AUTHORITY
(ACCOUNTCO, ACCOUNTUNIT, ACCOUNT)
BUDGET WORKSHEETS - Fiscal Year 2011-12

Page 35
CREDITS = (-)
DEBITS = (+)

Company 1 Niagara Frontier Transportation Authority
Division 03 NIAGARA FALLS INT'L AIRPORT
Department 0280 CONDOR AVIATION PROPERTY

Account	Description	2009-10 Actual	2010-11 Budget	2010-11 Sept. YTD Actual	2011-12 Req Budget	VARIANCE From Budget
431	BUILDING SPACE	6,835-	6,500-	5,226-	6,630-	130-
TOTAL	REVENUES	6,835-	6,500-	5,226-	6,630-	130-

NIAGARA FALLS INTERNATIONAL AIRPORT

PROJECT TITLE	PROJECT NUMBER	PRTY CL	JUST. CL	FUND SOURCE	TOTAL PROJECT BUDGET	PROJECT LIFE ACTUAL AS OF 7/19/10	TOTAL FORECASTED SPENDING 7/20/10	FISCAL YEAR 2011/2012	FISCAL YEAR 2012/2013	FISCAL YEAR 2013/2014	FISCAL YEAR 2014/2015	FISCAL YEAR 2015/2016	OUT YEARS
NFIA													
NEW TERMINAL BUILDING	2-1402		NI	CITY OF NF	\$1,000,000	\$1,000,000	\$0	\$0	\$0	\$0	\$0	\$0	\$0
				FTA	\$400,000	\$400,000	\$0	\$0	\$0	\$0	\$0	\$0	\$0
				NFIA CAPRES	\$1,445,822	\$1,445,822	\$0	\$0	\$0	\$0	\$0	\$0	\$0
				SEN BACKED LOAN	\$7,500,000	\$7,500,000	\$0	\$0	\$0	\$0	\$0	\$0	\$0
				NYS MOU	\$5,045,751	\$5,045,751	\$0	\$0	\$0	\$0	\$0	\$0	\$0
				NYS	\$2,000,000	\$2,000,000	\$0	\$0	\$0	\$0	\$0	\$0	\$0
				AIR 99	\$300,000	\$300,000	\$0	\$0	\$0	\$0	\$0	\$0	\$0
				ECONOMIC DEV	\$2,000,000	\$2,000,000	\$0	\$0	\$0	\$0	\$0	\$0	\$0
				NATIONAL FUEL	\$42,419	\$42,419	\$0	\$0	\$0	\$0	\$0	\$0	\$0
				NFTA	\$14,366	\$14,366	\$0	\$0	\$0	\$0	\$0	\$0	\$0
				FUTURE FUNDING	\$12,774,542	\$12,653,346	\$121,196	\$0	\$0	\$0	\$0	\$0	\$0
				TOTAL	\$32,522,900	\$32,401,704	\$121,196	\$0	\$0	\$0	\$0	\$0	\$0
NEW TERMINAL LANDSIDE IMPROVE. PHASE I													
	2-1405		NI	FAA	\$4,773,068	\$4,772,763	\$305	\$0	\$0	\$0	\$0	\$0	\$0
				NYSDOT	\$125,607	\$125,599	\$8	\$0	\$0	\$0	\$0	\$0	\$0
				NFTA	\$125,604	\$125,599	\$5	\$0	\$0	\$0	\$0	\$0	\$0
				FUTURE FUNDING	\$1,672,721	\$1,647,146	\$25,575	\$0	\$0	\$0	\$0	\$0	\$0
				TOTAL	\$6,697,000	\$6,671,107	\$25,893	\$0	\$0	\$0	\$0	\$0	\$0
NEW TERM. LANDSIDE IMP. PHASE II (PARK. LOT)													
	2-1433		NI	NFTA	\$1,026,400	\$1,019,495	\$6,905	\$0	\$0	\$0	\$0	\$0	\$0
FUEL FARM EXPANSION													
	2-1468		NI	NFTA	\$150,000	\$0	\$150,000	\$0	\$0	\$0	\$0	\$0	\$0
GATE 3 WALKWAY & JETBRIDGE													
	2-1458			FAA	\$818,399	\$0	\$818,399	\$0	\$0	\$0	\$0	\$0	\$0
				NYSDOT	\$21,537	\$0	\$21,537	\$0	\$0	\$0	\$0	\$0	\$0
				NFTA	\$21,537	\$0	\$21,537	\$0	\$0	\$0	\$0	\$0	\$0
				TOTAL	\$861,473	\$0	\$861,473	\$0	\$0	\$0	\$0	\$0	\$0
SAFETY AREA RW IMPROVEMENTS- R/W 6-24													
	2-1420		SR	FAA	\$14,039,100	\$477,786	\$141,804	\$13,419,510	\$0	\$0	\$0	\$0	\$0
				NYSDOT	\$369,450	\$12,573	\$3,732	\$353,145	\$0	\$0	\$0	\$0	\$0
				FUTURE PFC	\$369,450	\$12,573	\$3,732	\$353,145	\$0	\$0	\$0	\$0	\$0
				TOTAL	\$14,778,000	\$502,933	\$149,267	\$14,125,800	\$0	\$0	\$0	\$0	\$0

NIAGARA FALLS INTERNATIONAL AIRPORT

PROJECT TITLE	PROJECT NUMBER	PRTY CL	JUST. CL	FUND SOURCE	TOTAL PROJECT BUDGET	PROJECT LIFE ACTUAL AS OF 7/19/10	TOTAL FORECASTED SPENDING 7/20/10	FISCAL YEAR 2011/2012	FISCAL YEAR 2012/2013	FISCAL YEAR 2013/2014	FISCAL YEAR 2014/2015	FISCAL YEAR 2015/2016	OUT YEARS
NFIA													
CALSPAN AIRSIDE ACCESS ROAD	2-1464			FAA	\$115,071	\$0	\$21,261	\$93,810	\$0	\$0	\$0	\$0	\$0
				NYS DOT	\$3,028	\$0	\$560	\$2,469	\$0	\$0	\$0	\$0	\$0
				NFTA	\$560	\$0	\$560	\$0	\$0	\$0	\$0	\$0	\$0
				ADF	\$2,469	\$0	\$0	\$2,469	\$0	\$0	\$0	\$0	\$0
				TOTAL	\$121,127	\$0	\$22,380	\$98,747	\$0	\$0	\$0	\$0	\$0
MILL AND OVERLAY R/W 10L/28R													
	2-1454		SR	FAA	\$9,775,837	\$167	\$4,583	\$689,257	\$9,081,830	\$0	\$0	\$0	\$0
				AIRFORCE	\$5,145,177	\$88	\$2,412	\$362,767	\$4,779,911	\$0	\$0	\$0	\$0
				NYS DOT	\$257,259	\$4	\$121	\$18,138	\$238,996	\$0	\$0	\$0	\$0
				NFTA	\$239,121	\$4	\$121	\$0	\$238,996	\$0	\$0	\$0	\$0
				PFC	\$18,138	\$0	\$0	\$18,138	\$0	\$0	\$0	\$0	\$0
				TOTAL	\$15,435,532	\$263	\$7,237	\$1,088,300	\$14,339,732	\$0	\$0	\$0	\$0
NEW TERMINAL APRON - PHASE II													
	--		NI	FAA	\$4,863,742	\$0	\$0	\$0	\$357,231	\$4,506,510	\$0	\$0	\$0
				NYS DOT	\$127,993	\$0	\$0	\$0	\$9,401	\$118,592	\$0	\$0	\$0
				NFTA	\$127,993	\$0	\$0	\$0	\$9,401	\$118,592	\$0	\$0	\$0
				TOTAL	\$5,119,728	\$0	\$0	\$0	\$376,033	\$4,743,695	\$0	\$0	\$0
NEW MAINTENANCE BUILDING & EQUIP GARAGE													
	--			FAA	\$4,999,070	\$0	\$0	\$0	\$346,090	\$4,652,980	\$0	\$0	\$0
				NYS DOT	\$131,554	\$0	\$0	\$0	\$9,108	\$122,447	\$0	\$0	\$0
				<i>(formerly EXPAND EQUIP. STORAGE GARAGE)</i> NFTA	\$131,554	\$0	\$0	\$0	\$9,108	\$122,447	\$0	\$0	\$0
				TOTAL	\$5,262,179	\$0	\$0	\$0	\$364,305	\$4,897,874	\$0	\$0	\$0
PROPERTY ACQUISITION - RPZ - WEST END													
	--		NI	FAA	\$712,500	\$0	\$0	\$0	\$712,500	\$0	\$0	\$0	\$0
				NYS DOT	\$18,750	\$0	\$0	\$0	\$18,750	\$0	\$0	\$0	\$0
				NFTA	\$18,750	\$0	\$0	\$0	\$18,750	\$0	\$0	\$0	\$0
				TOTAL	\$750,000	\$0	\$0	\$0	\$750,000	\$0	\$0	\$0	\$0
RELOCATION OF TRITAUATOR BUILDING													
	--		NI	FAA	\$0	\$0	\$0	\$0	\$0	\$0	\$0	\$0	\$0
				NYS DOT	\$0	\$0	\$0	\$0	\$0	\$0	\$0	\$0	\$0
				NFTA	\$0	\$0	\$0	\$0	\$0	\$0	\$0	\$0	\$0
				TOTAL	\$0	\$0	\$0	\$0	\$0	\$0	\$0	\$0	\$0
DEMOLITION OF OLD TERMINAL													
	--		NI	FAA	\$0	\$0	\$0	\$0	\$0	\$0	\$0	\$0	\$0
				NYS DOT	\$0	\$0	\$0	\$0	\$0	\$0	\$0	\$0	\$0
				NFTA	\$0	\$0	\$0	\$0	\$0	\$0	\$0	\$0	\$0
				TOTAL	\$0	\$0	\$0	\$0	\$0	\$0	\$0	\$0	\$0
GENERAL AVIATION RELOCATION													
	--		NI	NFTA	\$0	\$0	\$0	\$0	\$0	\$0	\$0	\$0	\$0

NIAGARA FALLS INTERNATIONAL AIRPORT

PROJECT TITLE	PROJECT NUMBER	PRTY CL	JUST. CL	FUND SOURCE	TOTAL PROJECT BUDGET	PROJECT LIFE ACTUAL AS OF 7/19/10	TOTAL FORECASTED SPENDING 7/20/10	FISCAL YEAR 2011/2012	FISCAL YEAR 2012/2013	FISCAL YEAR 2013/2014	FISCAL YEAR 2014/2015	FISCAL YEAR 2015/2016	OUT YEARS
NFIA													
NEW TERMINAL APRON - PHASE III	--		NI	FAA	\$7,447,202	\$0	\$0	\$0	\$0	\$582,788	\$6,864,414	\$0	\$0
				NYS DOT	\$195,979	\$0	\$0	\$0	\$0	\$15,337	\$180,642	\$0	\$0
				NFTA	\$195,979	\$0	\$0	\$0	\$0	\$15,337	\$180,642	\$0	\$0
				TOTAL	\$7,839,160	\$0	\$0	\$0	\$0	\$613,461	\$7,225,699	\$0	\$0
REHABILITATE TAXIWAY C & H													
	--		SR	FAA	\$4,763,704	\$0	\$0	\$0	\$0	\$337,065	\$4,426,639	\$0	\$0
				NYS DOT	\$125,361	\$0	\$0	\$0	\$0	\$8,870	\$116,491	\$0	\$0
				NFTA	\$125,361	\$0	\$0	\$0	\$0	\$8,870	\$116,491	\$0	\$0
				TOTAL	\$5,014,425	\$0	\$0	\$0	\$0	\$354,805	\$4,659,620	\$0	\$0
REHABILITATION OF TAXIWAY L & M													
	--		SR	FAA	\$1,977,836	\$0	\$0	\$0	\$0	\$0	\$156,566	\$1,821,271	\$0
				NYS DOT	\$52,048	\$0	\$0	\$0	\$0	\$0	\$4,120	\$47,928	\$0
				NFTA	\$52,048	\$0	\$0	\$0	\$0	\$0	\$4,120	\$47,928	\$0
				TOTAL	\$2,081,933	\$0	\$0	\$0	\$0	\$0	\$164,806	\$1,917,127	\$0
REHABILITATION OF TAXIWAY E													
	--			FAA	\$10,396,815	\$0	\$0	\$0	\$0	\$0	\$0	\$776,976	\$9,619,840
J to be deleted)				NYS DOT	\$273,600	\$0	\$0	\$0	\$0	\$0	\$0	\$20,447	\$253,154
				NFTA	\$273,600	\$0	\$0	\$0	\$0	\$0	\$0	\$20,447	\$253,154
				TOTAL	\$10,944,016	\$0	\$0	\$0	\$0	\$0	\$0	\$817,869	\$10,126,147
REALIGNMENT T/W C & WEST RAMP EXPANSION													
	--		NI	FAA	\$9,466,568	\$0	\$0	\$0	\$0	\$0	\$0	\$817,986	\$8,648,582
				NYS DOT	\$249,120	\$0	\$0	\$0	\$0	\$0	\$0	\$21,526	\$227,594
(formerly RELOCATE SECTION OF T/W 'K' & RENAME TO 'C')				NFTA	\$249,120	\$0	\$0	\$0	\$0	\$0	\$0	\$21,526	\$227,594
				TOTAL	\$9,964,808	\$0	\$0	\$0	\$0	\$0	\$0	\$861,038	\$9,103,770
TAXIWAY 'N' NEW CONSTRUCTION													
	--		NI	FAA	\$31,504,631	\$0	\$0	\$0	\$0	\$0	\$0	\$2,306,896	\$29,197,734
				NYS DOT	\$829,069	\$0	\$0	\$0	\$0	\$0	\$0	\$60,708	\$768,361
				NFTA	\$829,069	\$0	\$0	\$0	\$0	\$0	\$0	\$60,708	\$768,361
				TOTAL	\$33,162,769	\$0	\$0	\$0	\$0	\$0	\$0	\$2,428,312	\$30,734,457
GATE 4 ACCESS DR WIDEN/SEC. GATE UPGRADE													
	--		NI	FAA	\$321,902	\$0	\$0	\$0	\$0	\$0	\$0	\$38,403	\$283,499
				NYS DOT	\$8,471	\$0	\$0	\$0	\$0	\$0	\$0	\$1,011	\$7,461
				NFTA	\$8,471	\$0	\$0	\$0	\$0	\$0	\$0	\$1,011	\$7,461
				TOTAL	\$338,844	\$0	\$0	\$0	\$0	\$0	\$0	\$40,424	\$298,420
RUNWAY 28R - CAT II UPGRADE													
	--		NI	NFTA	\$14,417,184	\$0	\$0	\$0	\$0	\$0	\$0	\$907,068	\$13,510,116
CARGO AREA APRONS & ROADS													
	2-1424		NI	FAA	\$25,706,008	\$90,742	\$0	\$0	\$0	\$0	\$0	\$0	\$25,615,266
	2-1425			NYS DOT	\$676,474	\$2,388	\$0	\$0	\$0	\$0	\$0	\$0	\$674,086
				NFTA	\$676,474	\$2,388	\$0	\$0	\$0	\$0	\$0	\$0	\$674,086
				TOTAL	\$27,058,956	\$95,518	\$0	\$0	\$0	\$0	\$0	\$0	\$26,963,438

NIAGARA FALLS INTERNATIONAL AIRPORT

PROJECT TITLE	PROJECT NUMBER	PRTY CL	JUST. CL	FUND SOURCE	TOTAL PROJECT BUDGET	PROJECT LIFE ACTUAL AS OF 7/19/10	TOTAL FORECASTED SPENDING 7/20/10	FISCAL YEAR 2011/2012	FISCAL YEAR 2012/2013	FISCAL YEAR 2013/2014	FISCAL YEAR 2014/2015	FISCAL YEAR 2015/2016	OUT YEARS
NFIA													
FAA CONTROL TOWER	--			FAA	\$0	\$0	\$0	\$0	\$0	\$0	\$0	\$0	\$0
				NYSDOT	\$0	\$0	\$0	\$0	\$0	\$0	\$0	\$0	\$0
				NFTA	\$0	\$0	\$0	\$0	\$0	\$0	\$0	\$0	\$0
				TOTAL	\$0	\$0	\$0	\$0	\$0	\$0	\$0	\$0	\$0
MASTER PLAN UPDATE	--	M	NR	FAA	\$760,000	\$0	\$0	\$38,000	\$646,000	\$71,250	\$4,750	\$0	\$0
				NYSDOT	\$20,000	\$0	\$0	\$1,000	\$17,000	\$1,875	\$125	\$0	\$0
				NFTA	\$19,000	\$0	\$0	\$0	\$17,000	\$1,875	\$125	\$0	\$0
				ADF	\$1,000	\$0	\$0	\$1,000	\$0	\$0	\$0	\$0	\$0
				TOTAL	\$800,000	\$0	\$0	\$40,000	\$680,000	\$75,000	\$5,000	\$0	\$0
ENVIRONMENTAL ASSESSMENT	--	M	NR	FAA	\$342,000	\$0	\$0	\$0	\$0	\$190,000	\$133,000	\$19,000	\$0
				NYSDOT	\$9,000	\$0	\$0	\$0	\$0	\$5,000	\$3,500	\$500	\$0
				NFTA	\$9,000	\$0	\$0	\$0	\$0	\$5,000	\$3,500	\$500	\$0
				TOTAL	\$360,000	\$0	\$0	\$0	\$0	\$200,000	\$140,000	\$20,000	\$0
WILDLIFE HAZARD MGMT PLAN	2-1469	M	NR	FAA	\$67,731	\$0	\$25,192	\$42,539	\$0	\$0	\$0	\$0	\$0
				NYSDOT	\$1,782	\$0	\$663	\$1,119	\$0	\$0	\$0	\$0	\$0
				NFTA	\$663	\$0	\$663	\$0	\$0	\$0	\$0	\$0	\$0
				ADF	\$1,119	\$0	\$0	\$1,119	\$0	\$0	\$0	\$0	\$0
				TOTAL	\$71,296	\$0	\$26,518	\$44,778	\$0	\$0	\$0	\$0	\$0
PART 77 OBSTRUCTION REMOVAL	2-1423		SR	FAA	\$1,331,831	\$75,835	\$131,361	\$76,000	\$427,500	\$612,750	\$8,385	\$0	\$0
	2-1453			NYSDOT	\$35,048	\$1,996	\$3,457	\$2,000	\$11,250	\$16,125	\$221	\$0	\$0
	2-1421			NFTA	\$33,048	\$1,996	\$3,457	\$0	\$11,250	\$16,125	\$221	\$0	\$0
				ADF	\$2,000	\$0	\$0	\$2,000	\$0	\$0	\$0	\$0	\$0
				TOTAL	\$1,401,927	\$79,826	\$138,275	\$80,000	\$450,000	\$645,000	\$8,826	\$0	\$0
WEST END TENANT BUILDING	--		NI	NFTA	\$408,618	\$0	\$0	\$0	\$0	\$408,618	\$0	\$0	\$0
REROOF GA BUILDING	--		SR	NFTA	\$66,129	\$0	\$0	\$0	\$66,129	\$0	\$0	\$0	\$0
				ADF	\$17,204	\$0	\$0	\$17,204	\$0	\$0	\$0	\$0	\$0
				TOTAL	\$83,333	\$0	\$0	\$17,204	\$66,129	\$0	\$0	\$0	\$0
CONNECT FIBER OPTIC PROJECTS	--			NFTA	\$78,000	\$0	\$0	\$0	\$78,000	\$0	\$0	\$0	\$0
EMPLOYEE PARKING LOT	--			NFTA	\$371,882	\$0	\$0	\$0	\$48,541	\$323,341	\$0	\$0	\$0
NFIA OPERATIONS													
PURCHASE OFFSITE PARKING LOT (NF BLVD)	--		NI	BNIA CAP RES	\$600,000	\$0	\$600,000	\$0	\$0	\$0	\$0	\$0	\$0
OFFSITE PARKING LOT-REV CONTROL			NI	NFTA	\$1,784,356	\$0	\$0	\$0	\$0	\$0	\$0	\$150,417	\$1,633,939
				ADF	\$200,000	\$0	\$0	\$200,000	\$0	\$0	\$0	\$0	\$0
				TOTAL	\$1,984,356	\$0	\$0	\$200,000	\$0	\$0	\$0	\$150,417	\$1,633,939
OFFSITE PARKING LOT-DESIGN PHASE I & 2	--		NI	NFTA	\$8,185,712	\$0	\$0	\$0	\$0	\$0	\$620,518	\$3,502,026	\$4,063,168

NIAGARA FALLS INTERNATIONAL AIRPORT

PROJECT TITLE	PROJECT NUMBER	PRTY CL	JUST. CL	FUND SOURCE	TOTAL PROJECT BUDGET	PROJECT LIFE ACTUAL AS OF 7/19/10	TOTAL FORECASTED SPENDING 7/20/10	FISCAL YEAR 2011/2012	FISCAL YEAR 2012/2013	FISCAL YEAR 2013/2014	FISCAL YEAR 2014/2015	FISCAL YEAR 2015/2016	OUT YEARS
NFIA													
REPLACE RIDING MOWER	--		NR	NFTA	\$6,240	\$0	\$0	\$0	\$6,240	\$0	\$0	\$0	\$0
ROLLOVER PLOW W/ SPREADER REPLACEMENT	--		NR	PFC	\$340,931	\$0	\$340,931	\$0	\$0	\$0	\$0	\$0	\$0
R/W BROOM	2-1456		NR	FUTURE PFC	\$505,000	\$0	\$0	\$0	\$505,000	\$0	\$0	\$0	\$0
REPLACE DUMP TRUCK W/BLADE & SPREADER	2-1462		NR	FUTURE PFC	\$120,739	\$0	\$120,739	\$0	\$0	\$0	\$0	\$0	\$0
AIRFIELD PICKUP REPLACEMENT	--		NR	NFTA	\$123,636	\$0	\$0	\$0	\$40,000	\$41,200	\$42,436	\$0	\$0
NEW TERMINAL EQUIPMENT													
REPLACE SNOW BLOWER	--		NR	PFC	\$400,000	\$0	\$0	\$0	\$400,000	\$0	\$0	\$0	\$0
CONSTRUCT POLE BARN FOR SALT STORAGE	--			BNIA CAP. RES.	\$152,552	\$0	\$0	\$0	\$27,387	\$125,165	\$0	\$0	\$0
20 FT RUNWAY PLOW REPLACEMENT	--			PFC	\$340,931	\$0	\$340,931	\$0	\$0	\$0	\$0	\$0	\$0
ARM CUTTER ATTACHEMENT FOR TRACTOR	--			NFTA	\$50,000	\$0	\$0	\$0	\$50,000	\$0	\$0	\$0	\$0
SNOW MELTER	--			PENDING PFC	\$250,000	\$0	\$0	\$0	\$0	\$0	\$0	\$0	\$250,000
CBP OFFICE FURNITURE	2-1461		NI	NFTA	\$21,116	\$0	\$21,116	\$0	\$0	\$0	\$0	\$0	\$0
TERMINAL - NEW SEATING	--		NI	NFTA	\$104,000	\$0	\$0	\$0	\$0	\$0	\$104,000	\$0	\$0
PARKING - TOLL BOOTHS	2-1470		NI	NFTA	\$36,400	\$0	\$36,400	\$0	\$0	\$0	\$0	\$0	\$0
PARKING - BOBCAT SNOW REMOVAL	--		NI	NFTA	\$47,000	\$0	\$47,000	\$0	\$0	\$0	\$0	\$0	\$0
DEFIBULATORS (2)	--		NI	NFTA	\$2,682	\$0	\$2,682	\$0	\$0	\$0	\$0	\$0	\$0

FAA	\$134,183,014	\$5,417,293	\$1,142,906	\$14,359,115	\$11,571,151	\$10,953,343	\$11,593,753	\$5,780,532	\$73,364,920
FTA	\$400,000	\$400,000	\$0	\$0	\$0	\$0	\$0	\$0	\$0
NYS DOT	\$3,531,132	\$142,560	\$30,076	\$377,871	\$304,504	\$288,246	\$305,099	\$152,119	\$1,930,656
NFTA	\$30,030,673	\$1,163,848	\$290,445	\$0	\$593,414	\$1,061,405	\$1,072,053	\$4,711,630	\$21,137,879
ADF	\$223,792	\$0	\$0	\$223,792	\$0	\$0	\$0	\$0	\$0
NATIONAL FUEL	\$42,419	\$42,419	\$0	\$0	\$0	\$0	\$0	\$0	\$0
NYS AIR 99	\$300,000	\$300,000	\$0	\$0	\$0	\$0	\$0	\$0	\$0
PFC	\$1,100,000	\$0	\$681,862	\$18,138	\$400,000	\$0	\$0	\$0	\$0
CITY OF NF	\$1,000,000	\$1,000,000	\$0	\$0	\$0	\$0	\$0	\$0	\$0
NFIA CAPRES	\$1,445,822	\$1,445,822	\$0	\$0	\$0	\$0	\$0	\$0	\$0
SEN BACK. LOAN	\$7,500,000	\$7,500,000	\$0	\$0	\$0	\$0	\$0	\$0	\$0
NYS MOU	\$5,045,751	\$5,045,751	\$0	\$0	\$0	\$0	\$0	\$0	\$0
NYS	\$2,000,000	\$2,000,000	\$0	\$0	\$0	\$0	\$0	\$0	\$0
AIRFORCE	\$5,145,177	\$88	\$2,412	\$362,767	\$4,779,911	\$0	\$0	\$0	\$0
FUTURE FUND.	\$14,447,263	\$14,300,492	\$146,771	\$0	\$0	\$0	\$0	\$0	\$0
FUTURE PFC	\$995,189	\$12,573	\$124,471	\$353,145	\$505,000	\$0	\$0	\$0	\$0
PENDING PFC	\$250,000	\$0	\$0	\$0	\$0	\$0	\$0	\$0	\$250,000
BNIA CAP. RES.	\$752,552	\$0	\$600,000	\$0	\$27,387	\$125,165	\$0	\$0	\$0
ECONOMIC DEV	\$2,000,000	\$2,000,000	\$0	\$0	\$0	\$0	\$0	\$0	\$0
TOTAL	\$210,392,785	\$40,770,846	\$3,018,943	\$15,694,829	\$18,181,367	\$12,428,159	\$12,970,905	\$10,644,281	\$96,683,455

PROPERTY GROUP

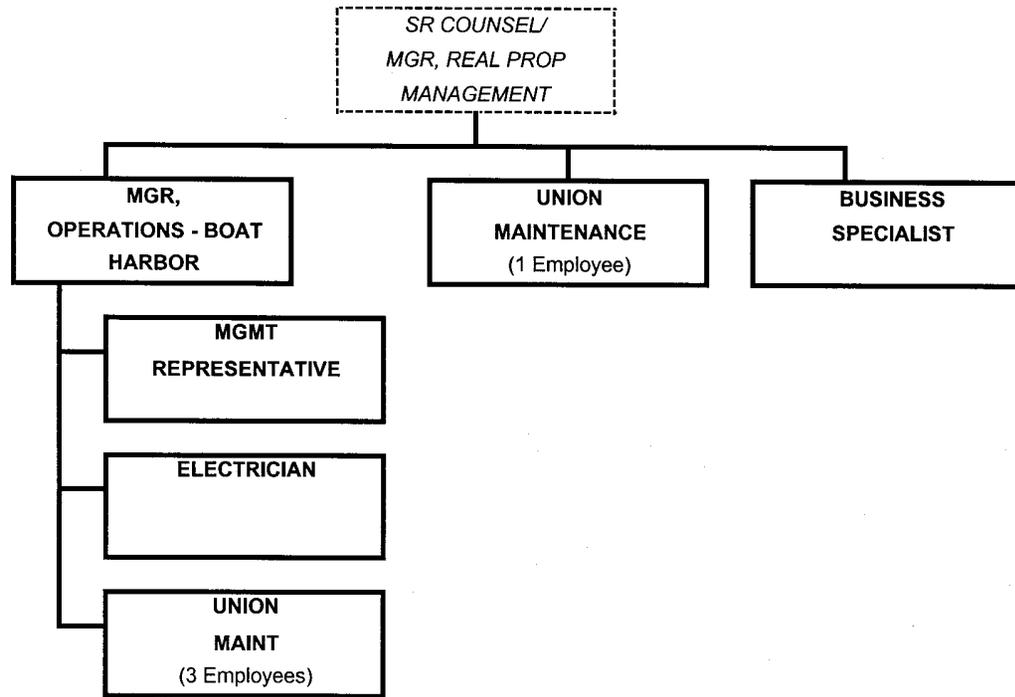

TOTAL EMPLOYEES 8

PROPERTY MANAGEMENT

2010/11 ANNUAL BUDGET

VS

2011/12 ANNUAL BUDGET

	FY 09-10 ACTUAL	FY 10-11 BUDGET	FY 11-12 BUDGET	VARIANCE	%
OPERATING REVENUES					
Boat Harbor Fees	835,540	865,500	973,000	107,500	12.4%
Rental Income	3,027,631	2,654,463	2,787,523	133,060	5.0%
Concessions/Commissions	35,937	55,300	66,000	10,700	19.3%
Retail Sales	204,543	240,000	275,000	35,000	14.6%
Resales & Rebillings	298,493	291,481	300,855	9,374	3.2%
Other Operating Revenues	<u>0</u>	<u>0</u>	<u>0</u>	<u>0</u>	<u>n/a</u>
TOTAL OPERATING REVENUES	4,402,144	4,106,744	4,402,378	295,634	7.2%
OPERATING EXPENSES (Excl. Depr.)					
Personnel Services	736,895	646,869	655,959	9,090	1.4%
Maintenance & Repairs	580,329	545,750	432,750	-113,000	-20.7%
Utilities	843,698	625,144	638,794	13,650	2.2%
Insurance & Injuries	32,514	117,733	144,314	26,581	22.6%
Safety & Security	0	8,000	80,238	72,238	903.0%
General Business/Other	668,976	698,402	734,476	36,074	5.2%
Administrative Cost Reallocation	1,094,929	1,140,499	1,061,274	-79,224	-6.9%
Costs Transferred to Capital Projects	-7,525	0	0	0	n/a
Inter Division Reimbursement	<u>-49,869</u>	<u>0</u>	<u>0</u>	<u>0</u>	<u>n/a</u>
TOTAL OPERATING EXPENSES	<u>3,899,947</u>	<u>3,782,397</u>	<u>3,747,805</u>	<u>-34,591</u>	<u>-0.9%</u>
OPERATING INCOME/(LOSS)	502,197	324,347	654,573	330,225	101.8%
NON-OPERATING ITEMS					
Property Management Debt Service	-335,200	-300,000	-266,000	34,000	-11.3%
Property Acquisition	<u>30,793</u>	<u>0</u>	<u>0</u>	<u>0</u>	<u>n/a</u>
TOTAL NON-OPERATING ITEMS	<u>-304,407</u>	<u>-300,000</u>	<u>-266,000</u>	<u>34,000</u>	<u>-11.3%</u>
NET INCOME/(LOSS)	197,790	24,347	388,573	364,225	1495.9%
LESS: DIRECT CAPITAL	800,047	692,866	518,821	-174,045	-25.1%
LESS: INDIRECT CAPITAL	<u>48,810</u>	<u>76,178</u>	<u>109,260</u>	<u>33,083</u>	<u>43.4%</u>
NET SURPLUS/(DEFICIT)	<u>-651,067</u>	<u>-744,696</u>	<u>-239,509</u>	<u>505,187</u>	<u>-67.8%</u>

THE PROPERTY GROUP

DESCRIPTION

The primary mission of the Property Group is to maximize revenue to the Authority on its non-public transportation assets through effective property management while improving and preserving the physical and financial integrity of these Authority-owned buildings, grounds and facilities. The NFTA Board of Commissioners has recognized that the activities of the Property Group provide an impetus to enhance the region's economic development potential. The Property Group serves as the Authority-wide provider of real estate services; acting as the negotiating entity for real estate matters.

Property Management Department

Currently the Business Center's portfolio of real estate includes 1.3± million square feet of industrial warehouse distribution and associated office space; 600± acres of developed and undeveloped real estate. Encumbering these properties are 120± leases of building space, ground rental, and occupancy/license agreements; 20+ miles of railroad rights of way containing in excess of 80 separate pipe, wire, and ground leases. In addition to the property management of these assets, the Business Center is responsible for establishing rental rates and tenant fees and the negotiation and preparation of real estate agreements in order to secure new tenants and provide for the renewal of existing contracts.

Real Estate Services

The Department is responsible for performing real estate services for all other NFTA divisions and Metro. This work is comprised of:

- Securing and analyzing real estate appraisals.
- Negotiating leases for the real estate of NFTA and Metro transportation operations.
- Seeking Requests for Proposals or competitive sealed bids for the sale of Authority and Metro owned real estate.
- Preparation of real estate net income analysis reports.
- Management of surplus transportation facilities.

Land Planning & Development Department

In order to capitalize on the value of NFTA's undeveloped land assets, the department manages land planning and development efforts. This activity provides for a sound financial basis for further NFTA investment in ancillary property.

PROGRAM GOALS AND OBJECTIVES

- 1.) Port Terminals A & B – To obtain new tenants to replace Sonwil. In order to protect the tenants, additional exterior brick repair/repointing is continuing.
- 2.) 247 Cayuga Road, Commerce Port - Continue leasing program with goal to maintain maximum occupancy and a program to replace HVAC units is underway.
- 3.) 485 Cayuga Road – Maximize revenue from building by obtaining new tenants to replace DRS.
- 4.) DL&W - Continue to progress the redevelopment of this facility in order to support community objectives.

KEY PERFORMANCE INDICATORS

PROPERTY GROUP

	<u>Financial Goals for FYE 2012</u>
Gross revenues from all sources	\$4,269,961
Direct operating expenses	<u>\$2,580,388</u>
Net operating income	\$1,689,573
Total Occupiable Sq. Ft.	1,122,641
Total Sq. Ft. Occupied	348,753
Occupancy Rate	31%

NIAGARA FRONTIER TRANSPORTATION AUTHORITY
(ACCOUNTCO, ACCOUNTUNIT, ACCOUNT)
BUDGET WORKSHEETS - Fiscal Year 2011-12

Company 1 Niagara Frontier Transportation Authority
Division 08 PROPERTY MANAGEMENT
Department 0099 ADMINISTRATIVE AND GENERAL

Account	Description	2009-10 Actual	2010-11 Budget	2010-11 Sept. YTD Actual	2011-12 Req Budget	VARIANCE From Budget
510	EMPLOYEE SALARIES	108,183	111,456	75,243	106,470	4,986-
515	EMPLOYEE BENEFITS	40,974	52,005	35,289	51,879	126-
534	TELEPHONE	3,803	4,041	2,595	3,800	241-
541	INSURANCE	107,315	92,059	66,121	93,826	1,767
542	CLAIM LOSSES	99,131-		282,108-		
571	CONSULTANTS/OUTSIDE SERVICES	119,990	116,896	126,513	117,168	272
574	TAXES AND ASSESSMENTS	71,864	71,808	53,856	71,808	
575	PRINTING & ADVERTISING	867	1,000		1,000	
576	EMPLOYEE TRAVEL	214	300	93	300	
577	EMPLOYEE TRAINING	70				
578	POSTAGE	330	500	54	300	200-
580	GENERAL OFFICE	1,450	899	181	900	1
591	PROJECTS	781-				
592	DIVISION OPERATIONS	8,271-		15,614		
TOTAL	EXPENSES	346,877	450,964	93,451	447,451	3,513-

08 PROPERTY MANAGEMENT
99 ADMINISTRATIVE AND GENERAL

EMPLOYEE GROUP: PB-ALL

Job Description	Grade/Step	Base Salary	Increase Amount	Longevity Amount	Scheduled Amount
BUSINESS SPECIALIST	8	52,407		1,500	53,907
NON-REP Totals	1	52,407		1,500	53,907
Sr. Maintenance Person	A 5	41,923	1,940		43,863
UNION Totals	1	41,923	1,940		43,863
Department Totals	2	94,330	1,940	1,500	97,770

NIAGARA FRONTIER TRANSPORTATION AUTHORITY
(ACCOUNTCO, ACCOUNTUNIT, ACCOUNT)
BUDGET WORKSHEETS - Fiscal Year 2011-12

Company 1 Niagara Frontier Transportation Authority
Division 08 PROPERTY MANAGEMENT
Department 0802 AIR CARGO BUFFALO

Account	Description	2009-10 Actual	2010-11 Budget	2010-11 Sept. YTD Actual	2011-12 Req Budget	VARIANCE From Budget
433	GROUND RENTALS	309,719-	280,084-	180,071-	300,000-	19,916-
	TOTAL REVENUES	309,719-	280,084-	180,071-	300,000-	19,916-

NIAGARA FRONTIER TRANSPORTATION AUTHORITY
(ACCOUNTCO, ACCOUNTUNIT, ACCOUNT)
BUDGET WORKSHEETS - Fiscal Year 2011-12

Company 1 Niagara Frontier Transportation Authority
Division 08 PROPERTY MANAGEMENT
Department 0804 AIRPORT ADVERTISING ROOM

Account	Description	2009-10 Actual	2010-11 Budget	2010-11 Sept. YTD Actual	2011-12 Req Budget	VARIANCE From Budget
433	GROUND RENTALS	7,447-	7,442-	5,585-	7,447-	5-
	TOTAL REVENUES	7,447-	7,442-	5,585-	7,447-	5-

NIAGARA FRONTIER TRANSPORTATION AUTHORITY
(ACCOUNTCO, ACCOUNTUNIT, ACCOUNT)
BUDGET WORKSHEETS - Fiscal Year 2011-12

Company 1 Niagara Frontier Transportation Authority
Division 08 PROPERTY MANAGEMENT
Department 0805 BOCES

Account	Description	2009-10 Actual	2010-11 Budget	2010-11 Sept. YTD Actual	2011-12 Req Budget	VARIANCE From Budget
439	OTHER RENTALS	4,968-	4,968-	3,726-	4,968-	
462	REBILLINGS	7,216-	4,000-	2,977-	5,000-	1,000-
	TOTAL REVENUES	12,184-	8,968-	6,703-	9,968-	1,000-

NIAGARA FRONTIER TRANSPORTATION AUTHORITY
(ACCOUNTCO, ACCOUNTUNIT, ACCOUNT)
BUDGET WORKSHEETS - Fiscal Year 2011-12

Company 1 Niagara Frontier Transportation Authority
Division 08 PROPERTY MANAGEMENT
Department 0806 235 AERO DRIVE

Account	Description	2009-10 Actual	2010-11 Budget	2010-11 Sept. YTD Actual	2011-12 Req Budget	VARIANCE From Budget
431	BUILDING SPACE	49,069-	50,291-	37,697-	51,564-	1,273-
462	REBILLINGS	7,566-		2,272-	8,500-	8,500-
	TOTAL REVENUES	56,635-	50,291-	39,969-	60,064-	9,773-

NIAGARA FRONTIER TRANSPORTATION AUTHORITY
(ACCOUNTCO, ACCOUNTUNIT, ACCOUNT)
BUDGET WORKSHEETS - Fiscal Year 2011-12

Company 1 Niagara Frontier Transportation Authority
Division 08 PROPERTY MANAGEMENT
Department 0806 235 AERO DRIVE

Account	Description	2009-10 Actual	2010-11 Budget	2010-11 Sept. YTD Actual	2011-12 Req Budget	VARIANCE From Budget
532	GAS	6,595	7,090	2,306	7,000	90-
533	WATER	1,405	1,310	731	1,500	190
TOTAL EXPENSES		8,000	8,400	3,037	8,500	100

NIAGARA FRONTIER TRANSPORTATION AUTHORITY
(ACCOUNTCO, ACCOUNTUNIT, ACCOUNT)
BUDGET WORKSHEETS - Fiscal Year 2011-12

Company 1 Niagara Frontier Transportation Authority
Division 08 PROPERTY MANAGEMENT
Department 0807 PRIOR

Account	Description	2009-10 Actual	2010-11 Budget	2010-11 Sept. YTD Actual	2011-12 Req Budget	VARIANCE From Budget
431	BUILDING SPACE	351,374-	352,500-	265,997-	362,000-	9,500-
	TOTAL REVENUES	351,374-	352,500-	265,997-	362,000-	9,500-

NIAGARA FRONTIER TRANSPORTATION AUTHORITY
(ACCOUNTCO, ACCOUNTUNIT, ACCOUNT)
BUDGET WORKSHEETS - Fiscal Year 2011-12

Company 1 Niagara Frontier Transportation Authority
Division 08 PROPERTY MANAGEMENT
Department 0807 PRIOR

Account	Description	2009-10 Actual	2010-11 Budget	2010-11 Sept. YTD Actual	2011-12 Req Budget	VARIANCE From Budget
533	WATER	2,218	2,282	1,685	2,300	18
	TOTAL EXPENSES	2,218	2,282	1,685	2,300	18

NIAGARA FRONTIER TRANSPORTATION AUTHORITY
(ACCOUNTCO, ACCOUNTUNIT, ACCOUNT)
BUDGET WORKSHEETS - Fiscal Year 2011-12

Company 1 Niagara Frontier Transportation Authority
Division 08 PROPERTY MANAGEMENT
Department 0808 CAYUGA COMMERCE CENTER

Account	Description	2009-10 Actual	2010-11 Budget	2010-11 Sept. YTD Actual	2011-12 Req Budget	VARIANCE From Budget
431	BUILDING SPACE	459,574-	310,004-	328,896-	250,700-	59,304
433	GROUND RENTALS	84,451-	84,600-	63,759-	84,700-	100-
TOTAL REVENUES		544,025-	394,604-	392,655-	335,400-	59,204

NIAGARA FRONTIER TRANSPORTATION AUTHORITY
(ACCOUNTCO, ACCOUNTUNIT, ACCOUNT)
BUDGET WORKSHEETS - Fiscal Year 2011-12

Company 1 Niagara Frontier Transportation Authority
Division 08 PROPERTY MANAGEMENT
Department 0808 CAYUGA COMMERCE CENTER

Account	Description	2009-10 Actual	2010-11 Budget	2010-11 Sept. YTD Actual	2011-12 Req Budget	VARIANCE From Budget
520	MAINTENANCE AND REPAIRS	46,092	45,000	26,900	45,000	
531	ELECTRIC POWER	68,083	67,696	59,860	68,000	304
532	GAS	22,870	22,349	8,455	24,000	1,651
533	WATER	9,426	10,055	6,498	10,000	55-
573	PROVISIONS AND RESERVES	1,405-				
TOTAL EXPENSES		145,066	145,100	101,713	147,000	1,900

QB204 Date 03/23/11
Time 14:17

NIAGARA FRONTIER TRANSPORTATION AUTHORITY
(ACCOUNTCO, ACCOUNTUNIT, ACCOUNT)
BUDGET WORKSHEETS - Fiscal Year 2011-12

Page 59
CREDITS = (-)
DEBITS = (+)

Company 1 Niagara Frontier Transportation Authority
Division 08 PROPERTY MANAGEMENT
Department 0810 DANNY'S WEST

Account	Description	2009-10 Actual	2010-11 Budget	2010-11 Sept. YTD Actual	2011-12 Req Budget	VARIANCE From Budget
433	GROUND RENTALS	5,218-	5,332-	3,953-	5,296-	36
TOTAL	REVENUES	5,218-	5,332-	3,953-	5,296-	36

NIAGARA FRONTIER TRANSPORTATION AUTHORITY
(ACCOUNTCO, ACCOUNTUNIT, ACCOUNT)
BUDGET WORKSHEETS - Fiscal Year 2011-12

Company 1 Niagara Frontier Transportation Authority
Division 08 PROPERTY MANAGEMENT
Department 0811 455 CAYUGA

Account	Description	2009-10 Actual	2010-11 Budget	2010-11 Sept. YTD Actual	2011-12 Req Budget	VARIANCE From Budget
431	BUILDING SPACE	181,015-	182,000-	133,256-	182,000-	
	TOTAL REVENUES	181,015-	182,000-	133,256-	182,000-	

QB204 Date 03/23/11
Time 14:17

NIAGARA FRONTIER TRANSPORTATION AUTHORITY
(ACCOUNTCO, ACCOUNTUNIT, ACCOUNT)
BUDGET WORKSHEETS - Fiscal Year 2011-12

Page 61
CREDITS = (-)
DEBITS = (+)

Company 1 Niagara Frontier Transportation Authority
Division 08 PROPERTY MANAGEMENT
Department 0812 MERCY FLIGHT

Account	Description	2009-10 Actual	2010-11 Budget	2010-11 Sept. YTD Actual	2011-12 Req Budget	VARIANCE From Budget
433	GROUND RENTALS	40,171-	40,975-	30,629-	41,794-	819-
	TOTAL REVENUES	40,171-	40,975-	30,629-	41,794-	819-

NIAGARA FRONTIER TRANSPORTATION AUTHORITY
(ACCOUNTCO, ACCOUNTUNIT, ACCOUNT)
BUDGET WORKSHEETS - Fiscal Year 2011-12

Company 1 Niagara Frontier Transportation Authority
Division 08 PROPERTY MANAGEMENT
Department 0814 195 HOLTZ DRIVE (A)

Account	Description	2009-10 Actual	2010-11 Budget	2010-11 Sept. YTD Actual	2011-12 Req Budget	VARIANCE From Budget
531	ELECTRIC POWER	1,231	1,303	950	1,400	97
532	GAS	214	192	85	200	8
TOTAL EXPENSES		1,445	1,495	1,035	1,600	105

NIAGARA FRONTIER TRANSPORTATION AUTHORITY
(ACCOUNTCO, ACCOUNTUNIT, ACCOUNT)
BUDGET WORKSHEETS - Fiscal Year 2011-12

Company 1 Niagara Frontier Transportation Authority
Division 08 PROPERTY MANAGEMENT
Department 0816 NWS WFO

Account	Description	2009-10	2010-11	2010-11	2011-12	VARIANCE
		Actual	Budget	Sept. YTD Actual	Req Budget	
433	GROUND RENTALS	2,522-	5,878-	185-	5,545-	333
	TOTAL REVENUES	2,522-	5,878-	185-	5,545-	333

QB204 Date 03/23/11
Time 14:17

NIAGARA FRONTIER TRANSPORTATION AUTHORITY
(ACCOUNTCO, ACCOUNTUNIT, ACCOUNT)
BUDGET WORKSHEETS - Fiscal Year 2011-12

Page 64
CREDITS = (-)
DEBITS = (+)

Company 1 Niagara Frontier Transportation Authority
Division 08 PROPERTY MANAGEMENT
Department 0816 NWS WFO

Account	Description	2009-10 Actual	2010-11 Budget	2010-11 Sept. YTD Actual	2011-12 Req Budget	VARIANCE From Budget
520	MAINTENANCE AND REPAIRS	8,175	4,750	3,500	3,750	1,000-
TOTAL	EXPENSES	8,175	4,750	3,500	3,750	1,000-

NIAGARA FRONTIER TRANSPORTATION AUTHORITY
(ACCOUNTCO, ACCOUNTUNIT, ACCOUNT)
BUDGET WORKSHEETS - Fiscal Year 2011-12

Company 1 Niagara Frontier Transportation Authority
Division 08 PROPERTY MANAGEMENT
Department 0818 SIERRA PLANT 3

Account	Description	2009-10 Actual	2010-11 Budget	2010-11 Sept. YTD Actual	2011-12 Req Budget	VARIANCE From Budget
431	BUILDING SPACE	588,283-	671,921-	580,011-	878,996-	207,075-
462	REBILLINGS	272,538-	284,081-	214,794-	287,355-	3,274-
TOTAL REVENUES		860,821-	956,002-	794,805-	1,166,351-	210,349-

NIAGARA FRONTIER TRANSPORTATION AUTHORITY
(ACCOUNTCO, ACCOUNTUNIT, ACCOUNT)
BUDGET WORKSHEETS - Fiscal Year 2011-12

Company 1 Niagara Frontier Transportation Authority
Division 08 PROPERTY MANAGEMENT
Department 0818 SIERRA PLANT 3

Account	Description	2009-10 Actual	2010-11 Budget	2010-11 Sept. YTD Actual	2011-12 Req Budget	VARIANCE From Budget
520	MAINTENANCE AND REPAIRS	355,865	260,000	163,617	250,000	10,000-
531	ELECTRIC POWER	238,873	263,733	224,940	300,000	36,267
532	GAS	67,043	80,940	26,460	90,000	9,060
533	WATER	7,451	7,432		7,500	68
534	TELEPHONE	7,623	4,711	3,859	5,500	789
TOTAL	EXPENSES	676,855	616,816	418,876	653,000	36,184

NIAGARA FRONTIER TRANSPORTATION AUTHORITY
(ACCOUNTCO, ACCOUNTUNIT, ACCOUNT)
BUDGET WORKSHEETS - Fiscal Year 2011-12

Company 1 Niagara Frontier Transportation Authority
Division 08 PROPERTY MANAGEMENT
Department 0841

Account	Description	2009-10 Actual	2010-11 Budget	2010-11 Sept. YTD Actual	2011-12 Req Budget	VARIANCE From Budget
433	GROUND RENTALS	420-	420-	420-	420-	
	TOTAL REVENUES	420-	420-	420-	420-	

QB204 Date 03/23/11
Time 14:17

NIAGARA FRONTIER TRANSPORTATION AUTHORITY
(ACCOUNTCO, ACCOUNTUNIT, ACCOUNT)
BUDGET WORKSHEETS - Fiscal Year 2011-12

Page 68
CREDITS = (-)
DEBITS = (+)

Company 1 Niagara Frontier Transportation Authority
Division 08 PROPERTY MANAGEMENT
Department 0842 CANADA CEMENT

Account	Description	2009-10 Actual	2010-11 Budget	2010-11 Sept. YTD Actual	2011-12 Req Budget	VARIANCE From Budget
433	GROUND RENTALS	12,500-				
	TOTAL REVENUES	12,500-				

NIAGARA FRONTIER TRANSPORTATION AUTHORITY
(ACCOUNTCO, ACCOUNTUNIT, ACCOUNT)
BUDGET WORKSHEETS - Fiscal Year 2011-12

Company 1 Niagara Frontier Transportation Authority
Division 08 PROPERTY MANAGEMENT
Department 0844 LAKESIDE ADVERTISING

Account	Description	2009-10 Actual	2010-11 Budget	2010-11 Sept. YTD Actual	2011-12 Req Budget	VARIANCE From Budget
433	GROUND RENTALS	34,531-	32,585-	24,645-	33,093-	508-
	TOTAL REVENUES	34,531-	32,585-	24,645-	33,093-	508-

NIAGARA FRONTIER TRANSPORTATION AUTHORITY
(ACCOUNTCO, ACCOUNTUNIT, ACCOUNT)
BUDGET WORKSHEETS - Fiscal Year 2011-12

Company 1 Niagara Frontier Transportation Authority
Division 08 PROPERTY MANAGEMENT
Department 0845 OUTER HARBOR

Account	Description	2009-10 Actual	2010-11 Budget	2010-11 Sept. YTD Actual	2011-12 Req Budget	VARIANCE From Budget
533	WATER	308	323	236	308	15-
	TOTAL EXPENSES	308	323	236	308	15-

QB204 Date 03/23/11
Time 14:17

NIAGARA FRONTIER TRANSPORTATION AUTHORITY
(ACCOUNTCO, ACCOUNTUNIT, ACCOUNT)
BUDGET WORKSHEETS - Fiscal Year 2011-12

Page 71
CREDITS = (-)
DEBITS = (+)

Company 1 Niagara Frontier Transportation Authority
Division 08 PROPERTY MANAGEMENT
Department 0847 PROP MGMT BUILDING

Account	Description	2009-10 Actual	2010-11 Budget	2010-11 Sept. YTD Actual	2011-12 Req Budget	VARIANCE From Budget
431	BUILDING SPACE	1,500-	1,500-	1,125-	1,500-	
	TOTAL REVENUES	1,500-	1,500-	1,125-	1,500-	

NIAGARA FRONTIER TRANSPORTATION AUTHORITY
(ACCOUNTCO, ACCOUNTUNIT, ACCOUNT)
BUDGET WORKSHEETS - Fiscal Year 2011-12

Company 1 Niagara Frontier Transportation Authority
Division 08 PROPERTY MANAGEMENT
Department 0850 TERMINAL A

Account	Description	2009-10 Actual	2010-11 Budget	2010-11 Sept. YTD Actual	2011-12 Req Budget	VARIANCE From Budget
431	BUILDING SPACE	222,659-	12,050-	74,820-		12,050
433	GROUND RENTALS	32,896-	11,290-	15,710-		11,290
461	RESALES	725		4,009-		
462	REBILLINGS	11,623-	3,400-	6,096-		3,400
TOTAL REVENUES		266,453-	26,740-	100,635-		26,740

NIAGARA FRONTIER TRANSPORTATION AUTHORITY
(ACCOUNTCO, ACCOUNTUNIT, ACCOUNT)
BUDGET WORKSHEETS - Fiscal Year 2011-12

Company 1 Niagara Frontier Transportation Authority
Division 08 PROPERTY MANAGEMENT
Department 0850 TERMINAL A

Account	Description	2009-10 Actual	2010-11 Budget	2010-11 Sept. YTD Actual	2011-12 Req Budget	VARIANCE From Budget
510	EMPLOYEE SALARIES	695		529		
515	EMPLOYEE BENEFITS	53		40		
520	MAINTENANCE AND REPAIRS	44,342	117,000	37,415	13,000	104,000-
524	AUTOMOTIVE	4,897	4,000	491	2,000	2,000-
531	ELECTRIC POWER	171,393	40,000	81,980	30,000	10,000-
532	GAS	157,236	40,000	27,887	10,000	30,000-
533	WATER	6,638	2,000	4,066	2,000	
571	CONSULTANTS/OUTSIDE SERVICES		32,000			32,000-
573	PROVISIONS AND RESERVES	822-				
TOTAL	EXPENSES	384,432	235,000	152,408	57,000	178,000-

QB204 Date 03/23/11
Time 14:17

NIAGARA FRONTIER TRANSPORTATION AUTHORITY
(ACCOUNTCO, ACCOUNTUNIT, ACCOUNT)
BUDGET WORKSHEETS - Fiscal Year 2011-12

Page 74
CREDITS = (-)
DEBITS = (+)

Company 1 Niagara Frontier Transportation Authority
Division 08 PROPERTY MANAGEMENT
Department 0851 TERMINAL B

Account	Description	2009-10 Actual	2010-11 Budget	2010-11 Sept. YTD Actual	2011-12 Req Budget	VARIANCE From Budget
431	BUILDING SPACE	106,500-	37,500-	45,500-		37,500
	TOTAL REVENUES	106,500-	37,500-	45,500-		37,500

QB204 Date 03/23/11
Time 14:17

NIAGARA FRONTIER TRANSPORTATION AUTHORITY
(ACCOUNTCO, ACCOUNTUNIT, ACCOUNT)
BUDGET WORKSHEETS - Fiscal Year 2011-12

Page 75
CREDITS = (-)
DEBITS = (+)

Company 1 Niagara Frontier Transportation Authority
Division 08 PROPERTY MANAGEMENT
Department 0852 VACANT LANDS

Account	Description	2009-10 Actual	2010-11 Budget	2010-11 Sept. YTD Actual	2011-12 Req Budget	VARIANCE From Budget
433	GROUND RENTALS	417,768-	436,623-	331,106-	456,000-	19,377-
	TOTAL REVENUES	417,768-	436,623-	331,106-	456,000-	19,377-

NIAGARA FRONTIER TRANSPORTATION AUTHORITY
(ACCOUNTCO, ACCOUNTUNIT, ACCOUNT)
BUDGET WORKSHEETS - Fiscal Year 2011-12

Company 1 Niagara Frontier Transportation Authority
Division 08 PROPERTY MANAGEMENT
Department 0853 BOAT HARBOR

Account	Description	2009-10 Actual	2010-11 Budget	2010-11 Sept. YTD Actual	2011-12 Req Budget	VARIANCE From Budget
421	PLEASURE CRAFT	835,540-	865,500-	963,370-	973,000-	107,500-
433	GROUND RENTALS	29,539-	30,000-	30,077-	30,000-	
441	CONCESSIONS	35,830-	55,000-	51,682-	65,000-	10,000-
442	COMMISSIONS	107-	300-	659-	1,000-	700-
453	GASOLINE & DIESEL FUEL	204,530-	240,000-	250,486-	275,000-	35,000-
454	CLOTHING & ACCESSORIES	13-				
462	REBILLINGS	272-				
TOTAL	REVENUES	1,105,831-	1,190,800-	1,296,274-	1,344,000-	153,200-

NIAGARA FRONTIER TRANSPORTATION AUTHORITY
(ACCOUNTCO, ACCOUNTUNIT, ACCOUNT)
BUDGET WORKSHEETS - Fiscal Year 2011-12

Company 1 Niagara Frontier Transportation Authority
Division 08 PROPERTY MANAGEMENT
Department 0853 BOAT HARBOR

Account	Description	2009-10 Actual	2010-11 Budget	2010-11 Sept. YTD Actual	2011-12 Req Budget	VARIANCE From Budget
510	EMPLOYEE SALARIES	422,392	331,555	259,922	337,159	5,604
515	EMPLOYEE BENEFITS	164,587	151,850	119,576	160,451	8,601
520	MAINTENANCE AND REPAIRS	64,658	72,999	51,724	73,000	1
524	AUTOMOTIVE	29,490	23,000	14,962	23,000	
526	JANITORIAL AND LAUNDRY	14,165	6,000	7,240	10,000	4,000
530	GROUNDS & LANDSCAPING	2,326	3,000	2,792	3,000	
531	ELECTRIC POWER	34,122	38,933	35,359	38,933	
532	GAS	7,613	4,173	2,038	4,173	
533	WATER	23,638	19,399	45,038	25,000	5,601
534	TELEPHONE	5,906	7,180	3,953	7,180	
541	INSURANCE	15,390	22,673	32,282	47,488	24,815
542	CLAIM LOSSES	8,938	3,000	1,100-	3,000	
551	ARMED GUARDS		8,000		80,238	72,238
571	CONSULTANTS/OUTSIDE SERVICES	266,591	238,000	266,083	270,000	32,000
575	PRINTING & ADVERTISING	10,206	10,000	6,917	10,000	
577	EMPLOYEE TRAINING	99				
578	POSTAGE	1,047	1,499	103	1,500	1
579	COST OF GOODS SOLD	178,667	204,999	215,109	240,000	35,001
580	GENERAL OFFICE	5,737	6,499	7,168	6,500	1
589	OTHER OPERATING EXPENSES	14,069	14,000	11,923	15,000	1,000
591	PROJECTS	6,744-				
592	DIVISION OPERATIONS	41,597-		5,585-		

QB204 Date 03/23/11
Time 14:17

NIAGARA FRONTIER TRANSPORTATION AUTHORITY
(ACCOUNTCO, ACCOUNTUNIT, ACCOUNT)
BUDGET WORKSHEETS - Fiscal Year 2011-12

Page 78
CREDITS = (-)
DEBITS = (+)

Company 1 Niagara Frontier Transportation Authority
Division 08 PROPERTY MANAGEMENT
Department 0853 BOAT HARBOR

Account	Description	2009-10 Actual	2010-11 Budget	2010-11 Sept. YTD Actual	2011-12 Req Budget	VARIANCE From Budget
TOTAL EXPENSES		1,221,300	1,166,759	1,075,504	1,355,622	188,863

08 PROPERTY MANAGEMENT
0853 BOAT HARBOR

EMPLOYEE GROUP: PB-ALL

Job Description	Grade/Step		Base Salary	Increase Amount	Longevity Amount	Scheduled Amount
MANAGER, OPERATIONS	15	1	62,768		900	63,668
NON-REP Totals		1	62,768		900	63,668
Management Rep. Boat H	7	5	43,136	4,169	1,400	47,305
SR. MAINTENANCE PERSON	A	6	45,900		1,400	47,300
SR. MAINTENANCE PERSON	A	6	45,900		700	46,600
MAINTENANCE PERSON	A	5	41,923	1,940		43,863
ELECTRICIAN	A	4	40,076	1,847		41,923
UNION Totals		5	216,935	7,956	3,500	226,991
Department Totals		6	279,703	7,956	4,400	290,659

NIAGARA FRONTIER TRANSPORTATION AUTHORITY
(ACCOUNTCO, ACCOUNTUNIT, ACCOUNT)
BUDGET WORKSHEETS - Fiscal Year 2011-12

Company 1 Niagara Frontier Transportation Authority
Division 08 PROPERTY MANAGEMENT
Department 0881 RAILROAD PROPERTIES

Account	Description	2009-10 Actual	2010-11 Budget	2010-11 Sept. YTD Actual	2011-12 Req Budget	VARIANCE From Budget
433	GROUND RENTALS	85,498-	96,500-	64,311-	91,500-	5,000
	TOTAL REVENUES	85,498-	96,500-	64,311-	91,500-	5,000

NIAGARA FRONTIER TRANSPORTATION AUTHORITY
(ACCOUNTCO, ACCOUNTUNIT, ACCOUNT)
BUDGET WORKSHEETS - Fiscal Year 2011-12

Company 1 Niagara Frontier Transportation Authority
Division 08 PROPERTY MANAGEMENT
Department 0881 RAILROAD PROPERTIES

Account	Description	2009-10 Actual	2010-11 Budget	2010-11 Sept. YTD Actual	2011-12 Req Budget	VARIANCE From Budget
520	MAINTENANCE AND REPAIRS	10,311	10,000	18,572	10,000	
	TOTAL EXPENSES	10,311	10,000	18,572	10,000	

PROPERTY GROUP													
PROJECT TITLE	PROJECT NUMBER	PRTY CL	JUST. CL	FUND SOURCE	TOTAL PROJECT BUDGET	PROJECT LIFE ACTUAL AS OF 7/19/10	TOTAL FORECASTED SPENDING 7/20/10	FISCAL YEAR 2011/2012	FISCAL YEAR 2012/2013	FISCAL YEAR 2013/2014	FISCAL YEAR 2014/2015	FISCAL YEAR 2015/2016	OUT YEARS
PROPERTY MANAGEMENT													
485 CAYUGA ROAD - SEWER REPLACEMENT	--		SR	NFTA	\$60,000	\$0	\$0	\$0	\$60,000	\$0	\$0	\$0	\$0
DEMO. 195 HOLTZ A & B (ASBESTOS REMOVAL)	--		SR	NFTA	\$666,807	\$0	\$0	\$0	\$59,632	\$607,175	\$0	\$0	\$0
GREENBELT SHORELINE IMPROVEMENT PROJ.	2-0862			PROP CAP. RES.	\$25,000	\$0	\$25,000	\$0	\$0	\$0	\$0	\$0	\$0
				NYSDEC	\$11,512,965	\$11,342,012	\$170,953	\$0	\$0	\$0	\$0	\$0	\$0
				FHWA	\$613,227	\$607,706	\$5,521	\$0	\$0	\$0	\$0	\$0	\$0
				FTA	\$13,494	\$13,494	\$0	\$0	\$0	\$0	\$0	\$0	\$0
				ECC	\$3,384	\$3,384	\$0	\$0	\$0	\$0	\$0	\$0	\$0
				NFTA	\$899,285	\$885,810	\$13,475	\$0	\$0	\$0	\$0	\$0	\$0
				TOTAL	\$13,067,355	\$12,852,406	\$214,949	\$0	\$0	\$0	\$0	\$0	\$0
PORT PARKING LOTS REHAB.	--		SR	NFTA	\$752,000	\$0	\$0	\$0	\$96,771	\$655,229	\$0	\$0	\$0
485 CAYUGA FIRE LOOP VALVE REPLACEMENT	--			NFTA	\$65,250	\$0	\$65,250	\$0	\$0	\$0	\$0	\$0	\$0
247 CAYUGA ROAD HVAC UNIT	2-8011	M	SR	NFTA	\$47,437	\$7,437	\$0	\$25,000	\$15,000	\$0	\$0	\$0	\$0
TERMINAL 'A' BRICK REHAB. FYE 10-12	2-8013	M	SR	NFTA	\$316,337	\$75,493	\$150,844	\$0	\$90,000	\$0	\$0	\$0	\$0
TERMINAL 'A' BRICK REHAB. FYE 13-15	--	M	SR	NFTA	\$300,000	\$0	\$0	\$0	\$95,000	\$100,000	\$105,000	\$0	\$0
PORT PARKING LOT LIGHTING	--		SR	NFTA	\$15,000	\$0	\$0	\$0	\$15,000	\$0	\$0	\$0	\$0
485 CAYUGA ROAD ENERGY MANAGEMENT	--		NR	NFTA	\$30,000	\$0	\$0	\$0	\$30,000	\$0	\$0	\$0	\$0
485 CAYUGA REPLACE MAN DOORS	--		SR	NFTA	\$20,000	\$0	\$0	\$20,000	\$0	\$0	\$0	\$0	\$0
485 CAYUGA REPLACE BAY 5 LIGHTING	--		SR	NFTA	\$15,000	\$0	\$0	\$0	\$15,000	\$0	\$0	\$0	\$0
485 CAYUGA REPLACE HEAT PUMP	--		SR	NFTA	\$14,000	\$0	\$0	\$0	\$14,000	\$0	\$0	\$0	\$0
TERMINAL 'A' SIDING EXPANSION JOINT REPLACE.	--		SR	NFTA	\$147,408	\$0	\$0	\$0	\$0	\$147,408	\$0	\$0	\$0
235 AERO DRIVE ROOF REPLACEMENT	2-8012	M	SR	NFTA	\$231,911	\$29,934	\$201,977	\$0	\$0	\$0	\$0	\$0	\$0
485 CAYUGA REPLACE SOUTH DRIVEWAY	--		SR	NFTA	\$112,000	\$0	\$0	\$0	\$112,000	\$0	\$0	\$0	\$0
PORT TERMINAL 'A' ROOF REPLACEMENT	--	M	SR	NFTA	\$9,000,000	\$0	\$0	\$0	\$0	\$0	\$50,000	\$8,950,000	\$0
PAINTERS UNION BUILDING ACCESS ROAD REHAB	--		SR	NFTA	\$61,316	\$0	\$0	\$10,636	\$50,680	\$0	\$0	\$0	\$0
TONAWANDA R.O.W. DRAINAGE	--		SR	NFTA	\$305,713	\$0	\$0	\$0	\$55,062	\$250,651	\$0	\$0	\$0
MISCELLANEOUS FYE 11	2-8017	M	SR	NFTA	\$50,000	\$602	\$49,398	\$0	\$0	\$0	\$0	\$0	\$0
247 CAYUGA RESTROOM REHAB	--	M	SR	NFTA	\$6,732	\$0	\$6,732	\$0	\$0	\$0	\$0	\$0	\$0
				PROP CAP. RES.	\$15,268	\$0	\$15,268	\$0	\$0	\$0	\$0	\$0	\$0
				TOTAL	\$22,000	\$0	\$22,000	\$0	\$0	\$0	\$0	\$0	\$0

PROPERTY GROUP

PROJECT TITLE	PROJECT NUMBER	PRTY CL	JUST. CL	FUND SOURCE	TOTAL PROJECT BUDGET	PROJECT LIFE ACTUAL AS OF 7/19/10	TOTAL FORECASTED SPENDING 7/20/10	FISCAL YEAR 2011/2012	FISCAL YEAR 2012/2013	FISCAL YEAR 2013/2014	FISCAL YEAR 2014/2015	FISCAL YEAR 2015/2016	OUT YEARS
247 CAYUGA BUILDING UPGRADES 11	2-8015	M	SR	PROP CAP. RES.	\$80,000	\$24,431	\$55,569	\$0	\$0	\$0	\$0	\$0	\$0
PROPERTY MISCELLANEOUS FYE 12	--	M	SR	NFTA	\$50,000	\$0	\$0	\$50,000	\$0	\$0	\$0	\$0	\$0
247 CAYUGA BUILDING UPGRADES 12	--	M	SR	NFTA	\$83,000	\$0	\$0	\$83,000	\$0	\$0	\$0	\$0	\$0
485 CAYUGA HVAC UNITS REPLACEMENT	--	M	SR	NFTA	\$50,000	\$0	\$0	\$0	\$25,000	\$25,000	\$0	\$0	\$0

NFTA	\$13,299,196	\$999,276	\$487,676	\$188,636	\$733,145	\$1,785,463	\$155,000	\$8,950,000	\$0
NYSDEC	\$11,512,965	\$11,342,012	\$170,953	\$0	\$0	\$0	\$0	\$0	\$0
FHWA	\$613,227	\$607,706	\$5,521	\$0	\$0	\$0	\$0	\$0	\$0
PROP CAP. RES.	\$120,268	\$24,431	\$95,837	\$0	\$0	\$0	\$0	\$0	\$0
FTA	\$13,494	\$13,494	\$0	\$0	\$0	\$0	\$0	\$0	\$0
ECC	\$3,384	\$3,384	\$0	\$0	\$0	\$0	\$0	\$0	\$0
TOTAL	\$25,562,534	\$12,990,303	\$759,987	\$188,636	\$733,145	\$1,785,463	\$155,000	\$8,950,000	\$0

BOAT HARBOR

PROJECT TITLE	PROJECT NUMBER	PRTY CL	JUST. CL	FUND SOURCE	TOTAL PROJECT BUDGET	PROJECT LIFE ACTUAL AS OF 7/19/10	TOTAL FORECASTED SPENDING 7/20/10	FISCAL YEAR 2011/2012	FISCAL YEAR 2012/2013	FISCAL YEAR 2013/2014	FISCAL YEAR 2014/2015	FISCAL YEAR 2015/2016	OUT YEARS
BOAT HARBOR													
HARBOR MAINT. BLDG. REPLACE.	--	M	SR	NFTA	\$3,951,941	\$0	\$0	\$0	\$287,585	\$3,664,376	\$0	\$0	\$0
BH - MARINE STORE ROOF REPLACE	2-0425			NFTA	\$15,025	\$10,242	\$4,783	\$0	\$0	\$0	\$0	\$0	\$0
EQUIPMENT REPLACEMENT	--			NFTA	\$50,000	\$0	\$0	\$10,000	\$10,000	\$10,000	\$10,000	\$10,000	\$0
HARBOR BREAKWALL REHAB.	--			FUTURE FUNDING	\$4,094,685	\$0	\$0	\$0	\$313,545	\$3,781,140	\$0	\$0	\$0
WORK BOAT REHAB	2-0429	M	SR	BH CAP. RES.	\$120,000	\$0	\$120,000	\$0	\$0	\$0	\$0	\$0	\$0
GATE DOORS REPLACEMENT	--		SR	NFTA	\$0	\$0	\$0	\$0	\$0	\$0	\$0	\$0	\$0
				BH CAP. RES.	\$0	\$0	\$0	\$0	\$0	\$0	\$0	\$0	\$0
				TOTAL	\$0	\$0	\$0	\$0	\$0	\$0	\$0	\$0	\$0
H' DOCK REHAB	--		SR	BH CAP. RES.	\$0	\$0	\$0	\$0	\$0	\$0	\$0	\$0	\$0
MARINA SOFTWARE	2-0430	M	NI	BH CAP. RES.	\$20,000	\$0	\$20,000	\$0	\$0	\$0	\$0	\$0	\$0
FACILITIES BLDG. PARK. LOT REHAB.	--		NR	NFTA	\$498,960	\$0	\$0	\$0	\$63,440	\$435,520	\$0	\$0	\$0
RELOCATION OF TRAILER COUNTER	2-0428		NI	NFTA	\$10,267	\$0	\$10,267	\$0	\$0	\$0	\$0	\$0	\$0
				BH CAP. RES.	\$14,677	\$0	\$14,677	\$0	\$0	\$0	\$0	\$0	\$0
				TOTAL	\$24,944	\$0	\$24,944	\$0	\$0	\$0	\$0	\$0	\$0
SOUTH END SHELTER	--		NI	NFTA	\$25,000	\$0	\$0	\$25,000	\$0	\$0	\$0	\$0	\$0
LAUNCH RAMP REHABILITATION	--		NR	NFTA	\$210,185	\$0	\$0	\$210,185	\$0	\$0	\$0	\$0	\$0
MARINA REHAB SHORESIDE	--	M	SR	NFTA	\$90,000	\$0	\$0	\$30,000	\$30,000	\$30,000	\$0	\$0	\$0
MARINA REHAB WATERSIDE	--	M	SR	NFTA	\$90,000	\$0	\$0	\$30,000	\$30,000	\$30,000	\$0	\$0	\$0
JET SKI DOCKING	--	M	NI	NFTA	\$25,000	\$0	\$0	\$25,000	\$0	\$0	\$0	\$0	\$0
FISH CLEANING/BAIT SHOP RELACATION	--		NR	FURURE FUNDING	\$40,000	\$0	\$0	\$0	\$40,000	\$0	\$0	\$0	\$0
HARBOR DREDGING	--		SR	FURURE FUNDING	\$95,000	\$0	\$0	\$0	\$0	\$0	\$95,000	\$0	\$0

NFTA	\$4,966,378	\$10,242	\$15,050	\$330,185	\$421,005	\$4,169,896	\$10,000	\$10,000	\$0
FUTURE FUND.	\$4,229,685	\$0	\$0	\$0	\$353,545	\$3,781,140	\$95,000	\$0	\$0
BH CAP. RES.	\$154,677	\$0	\$154,677	\$0	\$0	\$0	\$0	\$0	\$0
TOTAL	\$9,350,740	\$10,242	\$169,727	\$330,185	\$774,550	\$7,951,036	\$105,000	\$10,000	\$0

EXECUTIVE

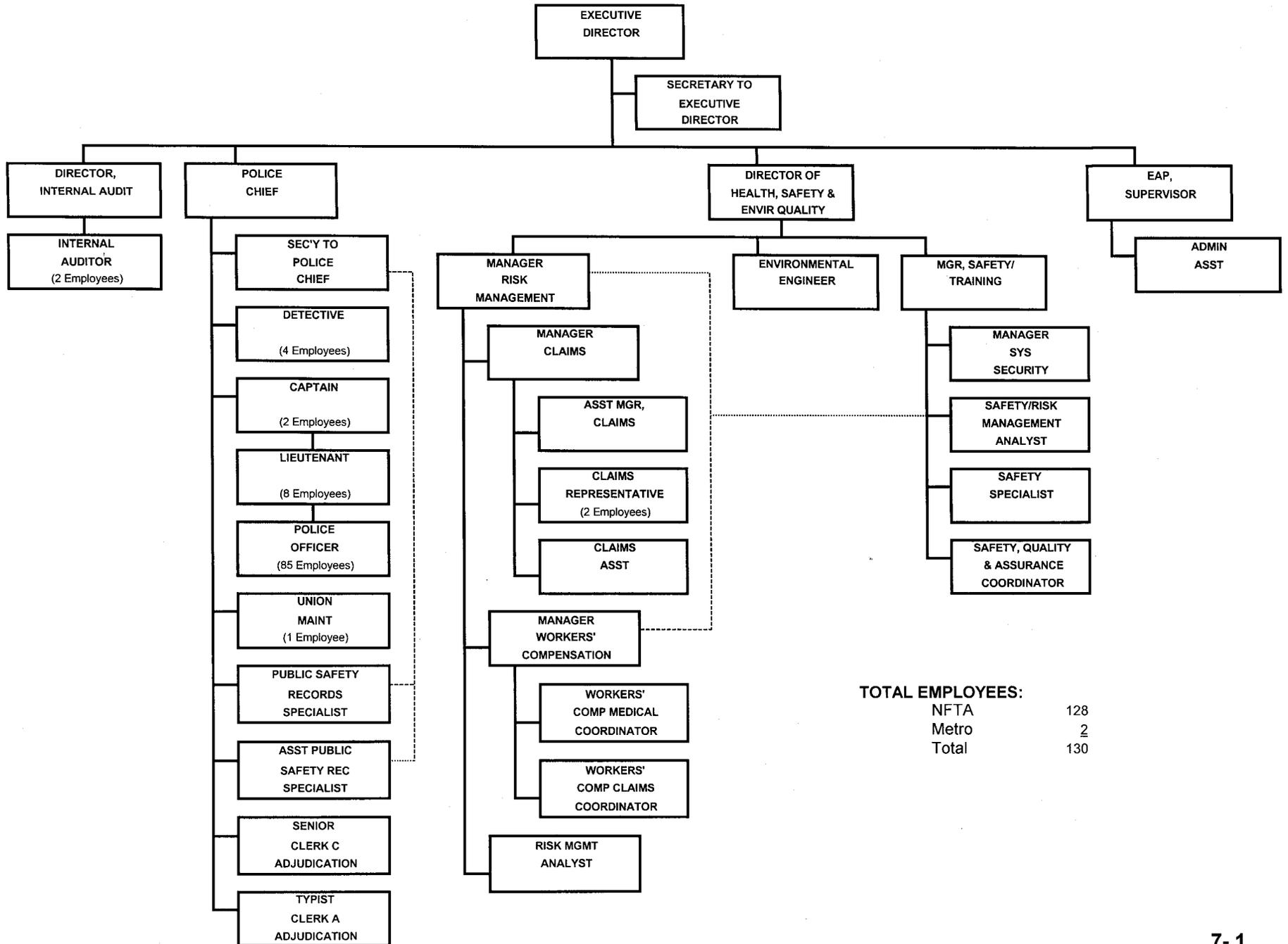

TOTAL EMPLOYEES:

NFTA	128
Metro	2
Total	130

EXECUTIVE
2010/11 ANNUAL BUDGET
VS
2011/12 ANNUAL BUDGET

	FY 09-10 ACTUAL	FY 10-11 BUDGET	FY 11-12 BUDGET	VARIANCE	%
OPERATING ASSISTANCE					
Federal Operating Assistance	324,234	778,760	308,705	-470,055	-60.4%
Federal - K-9 Cops	250,500	208,922	0	-208,922	-100.0%
Federal - TGSP Oper Asst	0	36,090	0	-36,090	-100.0%
Federal - CTU Grant	0	0	0	0	n/a
Federal - DEA Expenditures	6,740	0	0	0	n/a
Federal - DEA OT Reimbursement	<u>0</u>	<u>16,330</u>	<u>16,329</u>	<u>-1</u>	<u>0.0%</u>
TOTAL OPERATING ASSISTANCE	581,474	1,040,102	325,034	-715,068	-68.7%
OPERATING EXPENSES (Excl. Depr.)					
Personnel Services	13,171,534	12,862,278	13,438,712	576,434	4.5%
Maintenance & Repairs	99,031	116,598	99,900	-16,698	-14.3%
Utilities	49,835	50,134	45,865	-4,269	-8.5%
Insurance & Injuries	1,221,582	1,872,840	1,888,268	15,428	0.8%
Safety & Security	71,481	107,600	81,000	-26,600	-24.7%
General Business/Other	1,368,572	1,586,987	1,558,507	-28,480	-1.8%
Costs Transferred to Capital Projects	-166,180	-179,588	-874,060	-694,472	386.7%
Inter Division Reimbursement	<u>-11,193,117</u>	<u>-10,476,850</u>	<u>-11,081,856</u>	<u>-605,006</u>	<u>5.8%</u>
TOTAL OPERATING EXPENSES	<u>4,622,738</u>	<u>5,939,999</u>	<u>5,156,336</u>	<u>-783,663</u>	<u>-13.2%</u>
OPERATING INCOME/(LOSS)	-4,041,264	-4,899,897	-4,831,302	68,595	-1.4%
LESS: DIRECT CAPITAL	<u>297,970</u>	<u>477,272</u>	<u>633,991</u>	<u>156,719</u>	<u>32.8%</u>
NET SURPLUS/(DEFICIT)	<u>-4,339,234</u>	<u>-5,377,169</u>	<u>-5,465,293</u>	<u>-88,124</u>	<u>1.6%</u>

NIAGARA FRONTIER TRANSPORTATION AUTHORITY
(ACCOUNTCO, ACCOUNTUNIT, ACCOUNT)
BUDGET WORKSHEETS - Fiscal Year 2011-12

Company 1 Niagara Frontier Transportation Authority
Division 30 EXECUTIVE BRANCH
Department 0010 BOARD OF COMMISSIONER

Account	Description	2009-10 Actual	2010-11 Budget	2010-11 Sept. YTD Actual	2011-12 Req Budget	VARIANCE From Budget
571	CONSULTANTS/OUTSIDE SERVICES	7,988	17,000	6,598	9,500	7,500-
576	EMPLOYEE TRAVEL	700	5,000	992	3,200	1,800-
580	GENERAL OFFICE	14,034	19,000	10,379	16,000	3,000-
	TOTAL EXPENSES	22,722	41,000	17,969	28,700	12,300-

NIAGARA FRONTIER TRANSPORTATION AUTHORITY
(ACCOUNTCO, ACCOUNTUNIT, ACCOUNT)
BUDGET WORKSHEETS - Fiscal Year 2011-12

Company 1 Niagara Frontier Transportation Authority
Division 30 EXECUTIVE BRANCH
Department 0011 EXECUTIVE DIRECTOR

Account	Description	2009-10 Actual	2010-11 Budget	2010-11 Sept. YTD Actual	2011-12 Req Budget	VARIANCE From Budget
510	EMPLOYEE SALARIES	349,096	204,311	166,138	226,950	22,639
515	EMPLOYEE BENEFITS	135,119	115,062	77,625	110,026	5,036-
534	TELEPHONE	706	750	567	743	7-
571	CONSULTANTS/OUTSIDE SERVICES	177,931	175,000	110,969	178,000	3,000
576	EMPLOYEE TRAVEL	290	374		327	47-
578	POSTAGE	300	324	124	309	15-
580	GENERAL OFFICE	1,081	149	152	1,144	995
TOTAL EXPENSES		664,523	495,970	355,575	517,499	21,529

30 EXECUTIVE BRANCH
11 EXECUTIVE DIRECTOR

EMPLOYEE GROUP: PB-ALL

Job Description	Grade/Step	Base Salary	Increase Amount	Longevity Amount	Scheduled Amount
EXECUTIVE DIRECTOR	E1 0	170,000		500	170,500
SECRETARY TO EXECUTIVE	7 0	52,500		1,100	53,600
NON-REP Totals	2	222,500		1,600	224,100
Department Totals	2	222,500		1,600	224,100

QB204 Date 03/23/11
Time 14:17

NIAGARA FRONTIER TRANSPORTATION AUTHORITY
(ACCOUNTCO, ACCOUNTUNIT, ACCOUNT)
BUDGET WORKSHEETS - Fiscal Year 2011-12

Page 107
CREDITS = (-)
DEBITS = (+)

Company 2 NFT Metro System, Inc.
Division 30 EXECUTIVE BRANCH
Department 0012 EXEC DIR - DISCRETIONARY ITEMS

Account	Description	2009-10 Actual	2010-11 Budget	2010-11 Sept. YTD Actual	2011-12 Req Budget	VARIANCE From Budget
571	CONSULTANTS/OUTSIDE SERVICES	378,745	407,508	279,496	425,351	17,843
	TOTAL EXPENSES	378,745	407,508	279,496	425,351	17,843

INTERNAL AUDIT DEPARTMENT

KEY PERFORMANCE INDICATORS

DESCRIPTION

Internal Audit is an independent appraisal function established within the organization to examine and evaluate its activities. The Internal Audit department reports directly to the Board Audit and Governance Committee. This reporting relationship ensures departmental independence, promotes comprehensive audit coverage and assures adequate consideration of audit recommendations. Day to day administration is provided by the Executive Director.

The general responsibilities assigned to the internal auditors include evaluating, documenting and testing the NFTA's system of internal control and the reliability and operation of accounting and other reporting systems. The Internal Audit department checks for compliance with established policies, plans, procedures, governmental laws and regulations, and reviews the soundness and adequacy of the policies and procedures to accomplish their purpose at a reasonable cost. The Internal Audit department also verifies the existence of the Authority assets assuring proper safeguards are maintained, identifies opportunities for improved operational performance, coordinates the audit work with that of the external auditors, submits audit plans to the Audit and Governance Committee for review and evaluates specific programs and performs other special projects requested by management.

FYE 10
Actual

FYE 11
Current
Estimate

FYE 12
Budget

Number of Internal Financial, Operational and Performance Audits Performed and Reports Issued

5

2

5

Number of Lease and Contract Audits Performed and Reports Issued

12

10

15

Price analysis in accordance with the procurement guidelines

7

5

8

Test internal controls in accordance with the Model Governance Principles for Public Authorities

1

1

1

PROGRAM AND SERVICE OBJECTIVES

- The objective of Internal Audit is to assist members, activities, and functions of the organization to carry out their responsibilities efficiently and effectively. To this end, Internal Audit provides analysis, appraisals, recommendations, counsel and information concerning the activities reviewed.

NIAGARA FRONTIER TRANSPORTATION AUTHORITY
(ACCOUNTCO, ACCOUNTUNIT, ACCOUNT)
BUDGET WORKSHEETS - Fiscal Year 2011-12

Company 1 Niagara Frontier Transportation Authority
Division 30 EXECUTIVE BRANCH
Department 0013 INTERNAL AUDITORS

Account	Description	2009-10 Actual	2010-11 Budget	2010-11 Sept. YTD Actual	2011-12 Req Budget	VARIANCE From Budget
510	EMPLOYEE SALARIES	144,553	192,472	126,801	196,331	3,859
515	EMPLOYEE BENEFITS	56,933	90,269	59,470	94,920	4,651
520	MAINTENANCE AND REPAIRS	466	500		500	
571	CONSULTANTS/OUTSIDE SERVICES		1,500			1,500-
576	EMPLOYEE TRAVEL	131	1,250		630	620-
577	EMPLOYEE TRAINING	665	3,325	1,820	665	2,660-
578	POSTAGE	149	199	1	200	1
580	GENERAL OFFICE	934	1,498	874	1,135	363-
591	PROJECTS	6,054-	1,999-	1,447-	5,900-	3,901-
592	DIVISION OPERATIONS			1,228-		
TOTAL	EXPENSES	197,777	289,014	186,291	288,481	533-

30 EXECUTIVE BRANCH
13 INTERNAL AUDITORS

EMPLOYEE GROUP: PB-ALL

Job Description	Grade/Step	Base Salary	Increase Amount	Longevity Amount	Scheduled Amount
DIRECTOR OF INTERNAL A	20 1	89,190		900	90,090
INTERNAL AUDITOR	8	52,441		700	53,141
INTERNAL AUDITOR	8 0	50,000			50,000
NON-REP Totals	3	191,631		1,600	193,231
Department Totals	3	191,631		1,600	193,231

TRANSIT POLICE

DESCRIPTION

The Transit Police department is responsible for the protection and safety of passengers, employees and property of the Authority. The department provides security, law enforcement and investigative services for all divisions of the NFTA and Metro.

The department also oversees the Adjudication department. The Adjudication department is responsible for administration and collection of fines associated with fare evasion, parking and other violations of the Rules and Regulations of the Authority.

PROGRAM AND SERVICE OBJECTIVES

- Continue programs to provide a safe and secure system for all NFTA employees and the riding public at all NFTA facilities, Metro Bus, LRRT and the airports.
- Continue mandated DCJS training programs to increase the level of performance and professionalism of the police force.
- Effectively interpret and implement all relevant required federal, state, and local laws and programs.

KEY PERFORMANCE INDICATORS

	<u>FYE 10 Actual</u>	<u>FYE 11 Original Budget</u>	<u>FYE11 Current Estimate</u>	<u>FYE 12 Budget</u>
Service Calls	22,116	23,200	27,365	28,000
Incident Reports	2,414	2,400	3,011	3,500
Persons Arrested	841	850	956	1,050
NOV's (Parking & Other)	2,157	2,200	3,300	4,000
Individuals Covered by Photo ID Program @ BNIA	4,000	4,800	4,500	4,800
Number of Training Hours Needed to Comply with NYS In-service Training Requirements for Police	2,400	2,400	2,400	2,400
On the Job Injury Time Loss (man hrs.)	4,040	4,000	1,400	4,000

NIAGARA FRONTIER TRANSPORTATION AUTHORITY
(ACCOUNTCO, ACCOUNTUNIT, ACCOUNT)
BUDGET WORKSHEETS - Fiscal Year 2011-12

Company 1 Niagara Frontier Transportation Authority
Division 30 EXECUTIVE BRANCH
Department 0015 TRANSIT POLICE

Account	Description	2009-10 Actual	2010-11 Budget	2010-11 Sept. YTD Actual	2011-12 Req Budget	VARIANCE From Budget
510	EMPLOYEE SALARIES	7,683,613	6,939,494	6,006,324	7,203,400	263,906
515	EMPLOYEE BENEFITS	2,984,289	3,315,835	2,755,219	3,731,397	415,562
520	MAINTENANCE AND REPAIRS	5,045	8,799	4,925	4,950	3,849-
524	AUTOMOTIVE	89,367	103,999	117,950	90,250	13,749-
526	JANITORIAL AND LAUNDRY	3,261	3,300	2,666	3,300	
531	ELECTRIC POWER	14,141	16,591	12,242	15,667	924-
532	GAS	5,510	6,186	2,377	5,512	674-
533	WATER	2,019	2,049	1,553	2,073	24
534	TELEPHONE	23,488	18,908	14,026	17,641	1,267-
541	INSURANCE	173,558	144,329	92,709	129,546	14,783-
542	CLAIM LOSSES	44,135	50,000	17,576	42,000	8,000-
553	POLICE PROTECTION	71,481	107,600	37,006	81,000	26,600-
571	CONSULTANTS/OUTSIDE SERVICES	12,285	20,000	6,832	12,600	7,400-
577	EMPLOYEE TRAINING	4,012	2,796	7,012	4,012	1,216
578	POSTAGE	790	500	529	700	200
580	GENERAL OFFICE	25,063	16,999	21,466	20,900	3,901
591	PROJECTS	159,627-	177,588-	1,079,905-	865,500-	687,912-
592	DIVISION OPERATIONS	10,435,390-	9,575,790-	7,888,164-	10,174,414-	598,624-
TOTAL	EXPENSES	547,040	1,004,007	132,343	325,034	678,973-

NIAGARA FRONTIER TRANSPORTATION AUTHORITY
(ACCOUNTCO, ACCOUNTUNIT, ACCOUNT)
BUDGET WORKSHEETS - Fiscal Year 2011-12

Company 1 Niagara Frontier Transportation Authority
Division 30 EXECUTIVE BRANCH
Department 0015 TRANSIT POLICE

Account	Description	2009-10 Actual	2010-11 Budget	2010-11 Sept. YTD Actual	2011-12 Req Budget	VARIANCE From Budget
** NON-OPERATING/OPERATING ASSISTANCE **						
713	FEDERAL OPERATING ASSISTANCE	581,474-	1,004,012-	132,360-	325,034-	678,978
	TOTAL OPERATING ASSISTANCE	581,474-	1,004,012-	132,360-	325,034-	678,978

30 EXECUTIVE BRANCH
15 TRANSIT POLICE

EMPLOYEE GROUP: PB-ALL

Job Description	Grade/Step	Base Salary	Increase Amount	Longevity Amount	Scheduled Amount
POLICE OFFICER	A 3	50,544	1,643		52,187
POLICE OFFICER	A 3	50,544	1,643		52,187
POLICE OFFICER	A 3	50,544	1,643		52,187
POLICE OFFICER	A 3	50,544	1,643		52,187
POLICE OFFICER	A 3	50,544	1,643		52,187
POLICE OFFICER	A 3	50,544	1,643		52,187
POLICE OFFICER	A 3	50,544	1,643		52,187
POLICE OFFICER	A 3	50,544	1,643		52,187
POLICE OFFICER	A 3	50,544	1,643		52,187
POLICE OFFICER	A 3	50,544	1,643		52,187
POLICE OFFICER	A 3	50,544	1,643		52,187
POLICE OFFICER	A 3	50,544	1,643		52,187
POLICE OFFICER	A 3	50,544	1,643		52,187
POLICE OFFICER	A 2	45,572	4,972		50,544
MECHANIC	A 6	45,900		1,800	47,700
PUBLIC SAFETY RECORDS	4 6	37,299	1,887	1,400	40,586
ASST.PUBLIC SAFETY REC	3 6	34,190	2,224	500	36,914
UNION Totals	102	5,753,293	61,372	80,800	5,895,465
Department Totals	104	5,897,342	61,372	82,550	6,041,264

NIAGARA FRONTIER TRANSPORTATION AUTHORITY
(ACCOUNTCO, ACCOUNTUNIT, ACCOUNT)
BUDGET WORKSHEETS - Fiscal Year 2011-12

Company 2 NFT Metro System, Inc.
Division 30 EXECUTIVE BRANCH
Department 0052 ADJUDICATION

Account	Description	2009-10 Actual	2010-11 Budget	2010-11 Sept. YTD Actual	2011-12 Req Budget	VARIANCE From Budget
514	GEN & ADMIN SALARY & WAGES	89,735	93,545	68,322	92,341	1,204-
515	EMPLOYEE BENEFITS	61,299	64,359	48,526	65,008	649
571	CONSULTANTS/OUTSIDE SERVICES	2,250	2,500	1,250	2,250	250-
580	GENERAL OFFICE	19,546	16,000	15,217	13,633	2,367-
TOTAL	EXPENSES	172,830	176,404	133,315	173,232	3,172-

30 EXECUTIVE BRANCH
52 ADJUDICATION

EMPLOYEE GROUP: PB-ALL

Job Description	Grade/Step	Base Salary	Increase Amount	Longevity Amount	Scheduled Amount
SENIOR CLERK C	I 0	43,160		1,200	44,360
TYPIST CLERK A	K 0	42,806		1,200	44,006
UNION Totals	2	85,966		2,400	88,366
Department Totals	2	85,966		2,400	88,366

EMPLOYEE ASSISTANCE PROGRAM

DESCRIPTION

The Employee Assistance Program is responsible for providing direct services to all NFTA and NFTA Metro employees, employees' family members and retirees through interview assessments and appropriate referrals to community resource service providers so as to address various personal problems including problems related to alcohol and substance use/abuse, marital, financial, legal and a wide range of interpersonal conflicts in the workplace, the family unit and within the community. The department also provides information, relevant training and education to all levels of employees, including wellness programs and other health and mental health related services.

PROGRAM AND SERVICE OBJECTIVES

- Increase the awareness of employees as to the scope of the services provided by EAP, and the confidential manner in which cases are handled to increase employee utilization via paycheck attachments of pending EAP activities, distribution of printed material showing EAP's involvement.
- Identify and provide appropriate services to employees and family members who have problems specifically related to alcohol and/or substance use and abuse or other personal problems to reduce man hours lost due to absenteeism.
- Provide wellness programs of various categories to employees. (see indicators) including additional mini-wellness fairs.
- Provide intervention services in resolving problem situations which arise from interpersonal, inter-departmental and union/management conflicts as might be indicated.
- Provide follow-up services to new and existing clients as necessary.
- Develop and maintain skills through training in order to provide the best level of care possible to clients – skills enhancement.

- Continue to provide Critical Incident Stress Debriefing as might be indicated and additional training.

KEY PERFORMANCE INDICATORS

	<u>FYE 10 Actual</u>	<u>FYE 11 Original Budget</u>	<u>FYE 11 Current Estimate</u>	<u>FYE 12 Budget</u>
Provide Services to an Additional Group of New Clients ⁽¹⁾	44	37	50	50
Increase Number of Participants in Wellness Program ⁽²⁾	850	800 - 950	1,000 - 1,200	900 - 1,000
Implementation of Debriefing Encounter Based on Number of Incidents	2	3	3	3
Manager/Supervisor and Union Reps Trained in Detection of Drug/alcohol Use and Abuse (completed, but on going)	37	75	75	75
Provide Direct Intervention in Conflict Resolution to Other Departments	3	2-4	2-4	2-4
Skills Enhanced ⁽³⁾	5	4	4	4
Improve Cost/benefit Ratio	1:4	1:4	1:4	1:4
Orientation for New Bus Operators and Other Non-supervisory Personnel (re: drug/alcohol and EAP Services)	67	100	100	100

(1) Marketing – brochures and presentations

(2) Marketing – offer more popular items, heart, cholesterol, etc.

(3) Attend pertinent seminar and conferences

NIAGARA FRONTIER TRANSPORTATION AUTHORITY
(ACCOUNTCO, ACCOUNTUNIT, ACCOUNT)
BUDGET WORKSHEETS - Fiscal Year 2011-12

Company 1 Niagara Frontier Transportation Authority
Division 30 EXECUTIVE BRANCH
Department 0022 EMPLOYEE ASSISTANCE SERVICES

Account	Description	2009-10 Actual	2010-11 Budget	2010-11 Sept. YTD Actual	2011-12 Req Budget	VARIANCE From Budget
510	EMPLOYEE SALARIES	178,754	186,784	129,934	124,871	61,913-
515	EMPLOYEE BENEFITS	70,964	87,601	62,631	60,787	26,814-
534	TELEPHONE	2,523	3,486	2,148	2,816	670-
541	INSURANCE	944	490	701	496	6
572	RENT EXPENSE	13,033	12,940	10,027	13,033	93
576	EMPLOYEE TRAVEL	139	100	154	115	15
577	EMPLOYEE TRAINING	4,083	883	2,160	1,000	117
578	POSTAGE	88	347	90	280	67-
580	GENERAL OFFICE	3,574	2,412	1,554	2,372	40-
589	OTHER OPERATING EXPENSES	3,129	1,999	302	2,309	310
592	DIVISION OPERATIONS	66,652-	79,000-	57,740-	79,000-	
TOTAL	EXPENSES	210,579	218,042	151,961	129,079	88,963-

30 EXECUTIVE BRANCH
22 EMPLOYEE ASSISTANCE SERVICES

EMPLOYEE GROUP: PB-ALL

Job Description	Grade/Step	Base Salary	Increase Amount	Longevity Amount	Scheduled Amount
Supervisor EAP/SAP	13 0	78,700		1,100	79,800
EAP Administrative Ass	5	42,307		1,800	44,107
NON-REP Totals	2	121,007		2,900	123,907
Department Totals	2	121,007		2,900	123,907

HEALTH, SAFETY AND ENVIRONMENTAL QUALITY

DESCRIPTION

The health, safety and environmental quality department is responsible to develop, administer and promote programs aimed at protecting the safety and well being of employees, customers, the community and environment. The department also ensures compliance with local, state and federal regulations pertaining to health, safety and environmental protection.

SAFETY & TRAINING

The **safety** section of the Safety and Training department has two primary areas of oversight responsibility. The first area is operational safety, which focuses on Metro Bus, Metro Rail and Paratransit services. The second area is employee safety, which includes all NFTA employees.

As a public transportation provider, safety is incorporated into all phases of the organization. The end product of the operational safety component is the welfare and safety of our customers. The end product of the employee safety component is the safety and security of our employees. Each individual in this organization is continually challenged to produce this safety product.

Safety **training** is provided to all employees of the NFTA to ensure compliance and to help reduce injuries. Skills training is provided to all employees of Metro Bus, Metro Rail and Paratransit, as well as maintenance employees of the Metropolitan Transportation Center, the Niagara Falls International Transportation Center, the Operational Control Center and the Transit Police Headquarters. Skills training is provided to maintain the necessary skills needed to provide quality services throughout and to help reduce operational losses.

The training element of this department anticipates the need to meet the rapidly evolving technologies applied in today's transportation environment. Through continued education to employees, this organization will smoothly transition through new technological and transportation demands.

SECURITY

The **security** section of the group is responsible for systems Security Program Plan for the NFTA. This includes vulnerability assessment to identify the degree of vulnerability and the appropriate countermeasures needed to provide the necessary levels of protection. This group also monitors compliance with applicable transportation security policies, directives, regulations and agreements and acts as the Authority's liaison with local, state and federal law enforcement and intelligence agencies.

ENVIRONMENTAL

Environmental has two main areas of concentration. These include operational oversight for environmental compliance and environmental assessments to determine environmental impact of projects such as expansions, renovations and maintenance activities. The department ensures that sound environmental practices are observed and encourages open communication with employees, customers and the public regarding the NFTA's environmental program as well as any hazards that may arise from its operations. Environmental looks at ways to minimize waste, prevent pollution, and incorporate recycling in all practices and operations. Sound environmental practices are developed to minimize releases that may impact the environment.

PROGRAM AND SERVICE OBJECTIVES

- Interpret and implement all regulatory requirements as they relate to safety, security and the environment.
- Make operations safe for employees, customers and the environment.
- Reduce work related employee injuries and illnesses.
- Minimize waste and releases and examine recycling opportunities.
- Train employees to be aware of and responsive to environmental responsibilities.
- Identify operational vulnerabilities and select appropriate countermeasures to minimize losses.

NIAGARA FRONTIER TRANSPORTATION AUTHORITY
(ACCOUNTCO, ACCOUNTUNIT, ACCOUNT)
BUDGET WORKSHEETS - Fiscal Year 2011-12

Company 1 Niagara Frontier Transportation Authority
Division 30 EXECUTIVE BRANCH
Department 4036 SAFETY

Account	Description	2009-10 Actual	2010-11 Budget	2010-11 Sept. YTD Actual	2011-12 Req Budget	VARIANCE From Budget
510	EMPLOYEE SALARIES	453,616	477,802	306,588	458,285	19,517-
515	EMPLOYEE BENEFITS	177,994	220,634	143,889	221,281	647
520	MAINTENANCE AND REPAIRS	890		1,014	900	900
534	TELEPHONE	1,364	1,476	782	1,405	71-
571	CONSULTANTS/OUTSIDE SERVICES	36,265	73,000	47,117	60,850	12,150-
576	EMPLOYEE TRAVEL	3,487	3,000	2,441	3,450	450
577	EMPLOYEE TRAINING	3,636	1,581		2,530	949
578	POSTAGE	559	1,500	254	800	700-
580	GENERAL OFFICE	12,538	11,449	7,236	12,860	1,411
591	PROJECTS	499-			2,660-	2,660-
592	DIVISION OPERATIONS	312,505-	328,514-	221,556-	346,351-	17,837-
TOTAL	EXPENSES	377,345	461,928	287,765	413,350	48,578-

NIAGARA FRONTIER TRANSPORTATION AUTHORITY
(ACCOUNTCO, ACCOUNTUNIT, ACCOUNT)
BUDGET WORKSHEETS - Fiscal Year 2011-12

Company 1 Niagara Frontier Transportation Authority
Division 30 EXECUTIVE BRANCH
Department 4036 SAFETY

Account	Description	2009-10 Actual	2010-11 Budget	2010-11 Sept. YTD Actual	2011-12 Req Budget	VARIANCE From Budget
** NON-OPERATING/OPERATING ASSISTANCE **						
713	FEDERAL OPERATING ASSISTANCE		36,090-			36,090
	TOTAL OPERATING ASSISTANCE		36,090-			36,090

30 EXECUTIVE BRANCH
4036 SAFETY

EMPLOYEE GROUP: PB-ALL

Job Description	Grade/Step	Base Salary	Increase Amount	Longevity Amount	Scheduled Amount
ACTING MGR, HSEQ	18 0	86,796		900	87,696
MANAGER, SAFETY/TRAINI	15	67,904		1,800	69,704
Mgr. Sys. Security Eme	15	66,353		700	67,053
SAFETY ANALYST	8 0	46,349			46,349
SAFETY Q & A COORDINAT	8	44,770		500	45,270
NON-REP Totals	5	312,172		3,900	316,072
ENVIRONMENTAL ENGINEER	13 6	74,620	3,775	500	78,895
SAFETY SPECIALIST	4 2	46,546	8,847		55,393
UNION Totals	2	121,166	12,622	500	134,288
Department Totals	7	433,338	12,622	4,400	450,360

NIAGARA FRONTIER TRANSPORTATION AUTHORITY
(ACCOUNTCO, ACCOUNTUNIT, ACCOUNT)
BUDGET WORKSHEETS - Fiscal Year 2011-12

Company 2 NFT Metro System, Inc.
Division 40 METRO TRANS. AND MAINTENANCE
Department 4036 SAFETY & TRAINING

Account	Description	2009-10 Actual	2010-11 Budget	2010-11 Sept. YTD Actual	2011-12 Req Budget	VARIANCE From Budget
576	EMPLOYEE TRAVEL		25		25	
577	EMPLOYEE TRAINING		33,251			33,251-
580	GENERAL OFFICE	559	400	503	550	150
582	TRANSPORTATION EXPENSE	20,966	8,000	16,717	22,000	14,000
592	DIVISION OPERATIONS	50,104-	57,886-	35,816-	61,501-	3,615-
	TOTAL EXPENSES	28,579-	16,210-	18,596-	38,926-	22,716-

RISK MANAGEMENT

DESCRIPTION

The Risk Management department is responsible for protecting the financial assets of the NFTA and NFT Metro against the adverse effects of accidental losses; establishment of Authority wide risk management programs and procedures; determining whether to maintain or transfer risk exposures via contracts.

The responsibility of the Risk Management department specifically includes the control, procurement, and specification requirements of all property and casualty insurance policies; identifying and analyzing exposures and selecting appropriate risk management techniques to handle exposures; planning what work must be done to protect the Authority by managing workers' compensation, claims, and communicating with senior management the progress of the risk management program.

PROGRAMS AND SERVICES OBJECTIVES

- Process payments related to workers' compensation and disability in conjunction with Third Party Administration (TPA) agreements.
 - Review and maintain continuous insurance compliance protection under all leases, contracts and tenant agreements.
 - Participate in the Authority wide safety program.
-
- Maintain continuous protection of the Authority assets through self-insurance or risk transfer via insurance policies.
 - Forecast insurance costs and allocate costs to business centers on a cost of coverage basis so as to monitor annual insurance cost allocation to business centers and variances to budget.
 - Develop written procedures and operating policies on the risk management program.
 - Evaluate the overall effectiveness of the risk management program and make changes where needed.
 - Emphasize more loss control and coordinate with corporate safety to recommend training to decrease our frequency and severity of losses.
 - Control and direct the Workers' Compensation Third Party Administrator, as well as the internal claim process.

NIAGARA FRONTIER TRANSPORTATION AUTHORITY
(ACCOUNTCO, ACCOUNTUNIT, ACCOUNT)
BUDGET WORKSHEETS - Fiscal Year 2011-12

Company 1 Niagara Frontier Transportation Authority
Division 30 EXECUTIVE BRANCH
Department 0031 RISK MANAGEMENT

Account	Description	2009-10 Actual	2010-11 Budget	2010-11 Sept. YTD Actual	2011-12 Req Budget	VARIANCE From Budget
510	EMPLOYEE SALARIES	564,332	596,156	429,594	574,726	21,430-
515	EMPLOYEE BENEFITS	221,189	274,709	199,359	278,289	3,580
534	TELEPHONE	82	690		8	682-
571	CONSULTANTS/OUTSIDE SERVICES		10,000		5,000	5,000-
576	EMPLOYEE TRAVEL		250		250	
577	EMPLOYEE TRAINING	226	519	355	226	293-
578	POSTAGE	809	583	470	800	217
580	GENERAL OFFICE	7,754	10,500	4,817	7,585	2,915-
592	DIVISION OPERATIONS	378,569-	493,544-	295,123-	482,091-	11,453
	TOTAL EXPENSES	415,823	399,863	339,472	384,793	15,070-

30 EXECUTIVE BRANCH
31 RISK MANAGEMENT

EMPLOYEE GROUP: PB-ALL

Job Description	Grade/Step	Base Salary	Increase Amount	Longevity Amount	Scheduled Amount
MGR., RISK MANAGEMENT	18	75,000			75,000
Manager, Workers' Comp	14	63,995		700	64,695
MANAGER, CLAIMS	14	63,859			63,859
ASSISTANT MANAGER, CLA	11	58,728		500	59,228
CLAIMS REPRESENTATIVE	9	55,166			55,166
WC Claims Coord	9	54,636			54,636
CLAIMS REPRESENTATIVE	9	51,499		1,100	52,599
Workers' Comp. Medical	9	51,499			51,499
Risk Mgmt. Analyst	8	48,801			48,801
CLAIMS ASSISTANT		41,200			41,200
NON-REP Totals	10	564,383		2,300	566,683
Department Totals	10	564,383		2,300	566,683

CLAIMS DEPARTMENT

DESCRIPTION

The overall responsibility of the Claims department is the prompt, thorough investigation, evaluation, and reasonable settlement of claims against the Authority. The department administers, under Risk Management and in coordination with NFTA Counsel, self-insured aspects of Authority operations, including Metro Bus/Rail, BNIA, NFIA and various properties, with the exception of workers' compensation. No-fault claims, including arbitrations, small and commercial court actions, personal injury and property damage claims, property damage recoveries, and lawsuits, in conjunction with Counsel, are handled from initial investigation through resolution. Additionally, the department maintains accident statistics, prepares monthly and yearly accident summaries, and serves as an investigative resource and assistant in court-related matters for other departments.

PROGRAM AND SERVICE OBJECTIVES

- The primary objective is disposing of claims within budget.
- Continue development and refining of methods to track and evaluate accident data in order to facilitate reduction of accidents.
- Emphasize interdepartmental communication in order to increase organizational ability to reduce accidents.
- Continue refinement of methods by which other departments may access accident and cost information as necessary for their operations.
- Expedite investigation and recovery procedures by development of direct computer access to bus operational and mechanical data.
- Continue development and enactment of procedures for preservation of bus/rail video, digitalization of investigative and medical records of no-fault and litigated claims.

- Obtain training for current staff to keep up to date on issues effecting tort and no-fault claims as well as address the training needs of any replacement staff.

KEY PERFORMANCE INDICATORS

	FYE 10 <u>Actual</u>	FYE 11 <u>Original Budget</u>	FYE 11 <u>Current Estimate</u>	FYE 12 <u>Budget</u>
Total No-Fault Claims Submitted	278	171**	57**	200**
Total Property Damage Claims Submitted	162	100	43	129
Total Claims No-Fault Payments were made	192	189	92	146
Arbitration and City Court Matters Handled	45	20	16	45
Total Open Claims-Payment Anticipated:				
Metro	382	376	352	350
NFTA	45	44	36	40
Cases Settled:				
Lawsuits	42	47	16	57
Property Damage:				
Metro	88	73	26	65
NFTA	9	11	1	10
Personal Injury				
Metro	29	41*	9	40
NFTA	0	4	0	2
Sub Total	168	176	52	174
Settled by Collection:				
Metro	115	104	39	117
NFTA	8	10	3	6
Total Cases Settled	291	290	94	297

* Loss transfer claims settled are included in injury claims settled

** Number of bus collisions were down for FYE10 by 16%, but is climbing for FYE11 YTD (up 17% from FYE10)

NIAGARA FRONTIER TRANSPORTATION AUTHORITY
(ACCOUNTCO, ACCOUNTUNIT, ACCOUNT)
BUDGET WORKSHEETS - Fiscal Year 2011-12

Company 2 NFT Metro System, Inc.
Division 30 EXECUTIVE BRANCH
Department 0057 RAIL CLAIMS

Account	Description	2009-10 Actual	2010-11 Budget	2010-11 Sept. YTD Actual	2011-12 Req Budget	VARIANCE From Budget
513	I&D SALARY & WAGES	10	240		100	140-
515	EMPLOYEE BENEFITS	7				
542	CLAIM LOSSES	732,642-	78,000	21,897	61,800	16,200-
592	DIVISION OPERATIONS	128,679	179,414	91,551	151,474	27,940-
TOTAL	EXPENSES	603,946-	257,654	113,448	213,374	44,280-

NIAGARA FRONTIER TRANSPORTATION AUTHORITY
(ACCOUNTCO, ACCOUNTUNIT, ACCOUNT)
BUDGET WORKSHEETS - Fiscal Year 2011-12

Company 2 NFT Metro System, Inc.
Division 30 EXECUTIVE BRANCH
Department 0060 BUS CLAIMS

Account	Description	2009-10 Actual	2010-11 Budget	2010-11 Sept. YTD Actual	2011-12 Req Budget	VARIANCE From Budget
542	CLAIM LOSSES	1,735,583	1,600,020	1,471,882	1,654,426	54,406
571	CONSULTANTS/OUTSIDE SERVICES	625,645	755,702	452,213	747,146	8,556-
576	EMPLOYEE TRAVEL	6,479	8,999	4,627	7,125	1,874-
577	EMPLOYEE TRAINING	220	291	288	220	71-
592	DIVISION OPERATIONS	128,679-	179,414-	91,551-	151,474-	27,940
TOTAL EXPENSES		2,239,248	2,185,598	1,837,459	2,257,443	71,845

TRANSIT AUTHORITY POLICE DEPARTMENT

PROJECT TITLE	PROJECT NUMBER	PRTY CL	JUST. CL	FUND SOURCE	TOTAL PROJECT BUDGET	PROJECT LIFE ACTUAL AS OF 7/19/10	TOTAL FORECASTED SPENDING 7/20/10	FISCAL YEAR 2011/2012	FISCAL YEAR 2012/2013	FISCAL YEAR 2013/2014	FISCAL YEAR 2014/2015	FISCAL YEAR 2015/2016	OUT YEARS
TAP													
RADIOS	--		NR	88C	\$75,000	\$0	\$0	\$15,000	\$15,000	\$15,000	\$15,000	\$15,000	\$0
POLICE VEHICLES	--		NR	88C	\$300,000	\$0	\$0	\$60,000	\$60,000	\$60,000	\$60,000	\$60,000	\$0
MOBILE DATA COMPUTERS	--			88C	\$25,000	\$0	\$0	\$25,000	\$0	\$0	\$0	\$0	\$0
TIRE MACHINE	--		NR	88C	\$8,000	\$0	\$0	\$8,000	\$0	\$0	\$0	\$0	\$0
AIU SOFTWARE	--			88C	\$5,000	\$0	\$0	\$5,000	\$0	\$0	\$0	\$0	\$0
VEST	--			88C	\$90,000	\$0	\$0	\$18,000	\$18,000	\$18,000	\$18,000	\$18,000	\$0
WEAPONS	--			88C	\$5,000	\$0	\$0	\$5,000	\$0	\$0	\$0	\$0	\$0
REMODEL AT 181 ELLICOTT	--			NFTA	\$25,000	\$0	\$0	\$25,000	\$0	\$0	\$0	\$0	\$0
BNIA													
POLICE VEHICLES - REPLACEMENT	--		NR	PFC	\$300,000	\$0	\$0	\$60,000	\$60,000	\$60,000	\$60,000	\$60,000	\$0
RADIOS	--		NR	PFC	\$75,000	\$0	\$0	\$15,000	\$15,000	\$15,000	\$15,000	\$15,000	\$0
K9 - REPLACE	--		NR	PFC	\$175,000	\$0	\$0	\$35,000	\$35,000	\$35,000	\$35,000	\$35,000	\$0
NFIA													
POLICE VEHICLE	--		NR	NFTA	\$150,000	\$0	\$0	\$30,000	\$30,000	\$30,000	\$30,000	\$30,000	\$0

CHECK FUNDING FOR NFIA VEHICLE
 RIGHT NOW IT'S NFTA FUNDED

	88C	\$508,000	\$0	\$0	\$136,000	\$93,000	\$93,000	\$93,000	\$93,000	\$93,000	\$0
9/1/10 - CALLED JIM TO CHECK IF NFIA HAS VEHICLE IN PFC	PFC	\$550,000	\$0	\$0	\$110,000	\$110,000	\$110,000	\$110,000	\$110,000	\$110,000	\$0
9/1/10 - CALLED ANDREA TO CHECK ABOUT LEASING VEHICLES	NFTA	\$175,000	\$0	\$0	\$55,000	\$30,000	\$30,000	\$30,000	\$30,000	\$30,000	\$0
	COUNTER TERR	\$0	\$0	\$0	\$0	\$0	\$0	\$0	\$0	\$0	\$0
	TOTAL	\$1,233,000	\$0	\$0	\$301,000	\$233,000	\$233,000	\$233,000	\$233,000	\$233,000	\$0

SAFETY

PROJECT TITLE	PROJECT NUMBER	PRTY CL	JUST. CL	FUND SOURCE	TOTAL PROJECT BUDGET	PROJECT LIFE ACTUAL AS OF 7/19/10	TOTAL FORECASTED SPENDING 7/20/10	FISCAL YEAR 2011/2012	FISCAL YEAR 2012/2013	FISCAL YEAR 2013/2014	FISCAL YEAR 2014/2015	FISCAL YEAR 2015/2016	OUT YEARS
SAFETY													
UST REPLACEMENT (BABCOCK)	--			NFTA	\$2,415,000	\$0	\$0	\$0	\$285,000	\$2,130,000	\$0	\$0	\$0
PERIMETER SECURITY - FRONTIER	2-1057			TSGP 09	\$1,379,906	\$1,419	\$30,392	\$1,348,095	\$0	\$0	\$0	\$0	\$0
				NFTA	\$111,739	\$0	\$42,530	\$69,209	\$0	\$0	\$0	\$0	\$0
				TOTAL	\$1,491,645	\$1,419	\$72,922	\$1,417,304	\$0	\$0	\$0	\$0	\$0
PERIMETER SECURITY - COLD SPRINGS	2-1037			TSGP 08	\$831,952	\$20,793	\$48,080	\$763,079	\$0	\$0	\$0	\$0	\$0
				NFTA	\$68,057	\$1,333	\$9,362	\$57,362	\$0	\$0	\$0	\$0	\$0
				TOTAL	\$900,009	\$22,126	\$57,442	\$820,441	\$0	\$0	\$0	\$0	\$0
PERIMETER SECURITY - SOUTH PARK - PHASE II	2-9490			TSGP 09	\$2,102,846	\$0	\$39,256	\$2,063,590	\$0	\$0	\$0	\$0	\$0
				NFTA	\$127,224	\$0	\$43,405	\$83,819	\$0	\$0	\$0	\$0	\$0
				TOTAL	\$2,230,070	\$0	\$82,661	\$2,147,409	\$0	\$0	\$0	\$0	\$0
REGIONAL SURVEILLANCE CENTER	2-1048			TSGP SUP '08	\$691,497	\$0	\$691,497	\$0	\$0	\$0	\$0	\$0	\$0
				DHS 10	\$300,000	\$0	\$0	\$300,000	\$0	\$0	\$0	\$0	\$0
				UASI	\$499,998	\$0	\$499,998	\$0	\$0	\$0	\$0	\$0	\$0
				NFTA	\$650,332	\$98,155	\$252,177	\$300,000	\$0	\$0	\$0	\$0	\$0
				TOTAL	\$2,141,827	\$98,155	\$1,443,672	\$600,000	\$0	\$0	\$0	\$0	\$0
CRITICAL INFRASTRUCTURE PROTECTION	2-1039			TSGP 08	\$267,722	\$31,120	\$236,602	\$0	\$0	\$0	\$0	\$0	\$0
				NFTA	\$36,460	\$17,535	\$18,925	\$0	\$0	\$0	\$0	\$0	\$0
				TOTAL	\$304,182	\$48,655	\$255,527	\$0	\$0	\$0	\$0	\$0	\$0
LRRT STATION CCTV UPGRADE	2-1038			TSGP 08	\$1,183,410	\$130,590	\$1,038,672	\$14,148	\$0	\$0	\$0	\$0	\$0
				NFTA	\$35,613	\$27,172	\$8,342	\$99	\$0	\$0	\$0	\$0	\$0
				88C	\$74,951	\$21,599	\$52,598	\$754	\$0	\$0	\$0	\$0	\$0
				TOTAL	\$1,293,975	\$179,361	\$1,099,612	\$15,000	\$0	\$0	\$0	\$0	\$0
ARC FLASH STUDY	--			NFTA	\$65,502	\$0	\$0	\$65,502	\$0	\$0	\$0	\$0	\$0
CTU EQUIPMENT	--			TSGP ARRA	\$150,000	\$0	\$0	\$150,000	\$0	\$0	\$0	\$0	\$0
CANINE TEAM	--			TSGP ARRA	\$400,000	\$0	\$300,000	\$100,000	\$0	\$0	\$0	\$0	\$0
BNIA PERIMETER SECURITY	2-1049			DHS 09	\$3,058,573	\$661,428	\$2,397,145	\$0	\$0	\$0	\$0	\$0	\$0

SAFETY

PROJECT TITLE	PROJECT NUMBER	PRTY CL	JUST. CL	FUND SOURCE	TOTAL PROJECT BUDGET	PROJECT LIFE	TOTAL	FISCAL	FISCAL	FISCAL	FISCAL	FISCAL	OUT YEARS
						ACTUAL AS OF 7/19/10	FORECASTED SPENDING 7/20/10	YEAR 2011/2012	YEAR 2012/2013	YEAR 2013/2014	YEAR 2014/2015	YEAR 2015/2016	
SAFETY													
COMMUNICATIONS RADIOS	--			NFTA	\$5,000	\$0	\$5,000	\$0	\$0	\$0	\$0	\$0	\$0
COMPUTER EQUIPMENT	--			NFTA	\$4,500	\$0	\$0	\$3,000	\$1,500	\$0	\$0	\$0	\$0
WORKERS' COMP. DATA REPOSITORY	--			NFTA	\$100,000	\$0	\$0	\$0	\$100,000	\$0	\$0	\$0	\$0
TSGP TRAINING	15-			TSGP 07	\$220,880	\$0	\$220,880	\$0	\$0	\$0	\$0	\$0	\$0

	TSGP 07	\$220,880	\$0	\$220,880	\$0	\$0	\$0	\$0	\$0	\$0	\$0	\$0
	TSGP 08	\$2,283,084	\$182,503	\$1,323,354	\$777,227	\$0	\$0	\$0	\$0	\$0	\$0	\$0
UASI - Urban Area Security Initiative (Federal)	NFTA	\$3,619,427	\$144,195	\$379,741	\$578,991	\$386,500	\$2,130,000	\$0	\$0	\$0	\$0	\$0
TSGP - Transit Security Grant Program	TSGP 09	\$3,482,752	\$1,419	\$69,648	\$3,411,685	\$0	\$0	\$0	\$0	\$0	\$0	\$0
DHS - Department Homeland Security	TSGP SUP 08	\$691,497	\$0	\$691,497	\$0	\$0	\$0	\$0	\$0	\$0	\$0	\$0
	DHS 09	\$3,058,573	\$661,428	\$2,397,145	\$0	\$0	\$0	\$0	\$0	\$0	\$0	\$0
	UASI	\$499,998	\$0	\$499,998	\$0	\$0	\$0	\$0	\$0	\$0	\$0	\$0
	88C	\$74,951	\$21,599	\$52,598	\$754	\$0	\$0	\$0	\$0	\$0	\$0	\$0
	DHS 10	\$300,000	\$0	\$0	\$300,000	\$0	\$0	\$0	\$0	\$0	\$0	\$0
	TSGP ARRA	\$550,000	\$0	\$300,000	\$250,000	\$0	\$0	\$0	\$0	\$0	\$0	\$0
	TOTAL	\$14,781,163	\$1,011,144	\$5,934,862	\$5,318,657	\$386,500	\$2,130,000	\$0	\$0	\$0	\$0	\$0

EEO/DIVERSITY DEVELOPMENT

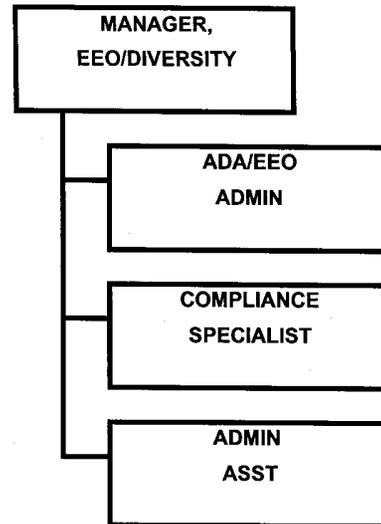

TOTAL EMPLOYEES 4

EEO/DIVERSITY DEVEL

2010/11 ANNUAL BUDGET

VS

2011/12 ANNUAL BUDGET

	FY 09-10	FY 10-11	FY 11-12	VARIANCE	%
	ACTUAL	BUDGET	BUDGET		
OPERATING EXPENSES (Excl. Depr.)					
Personnel Services	310,160	332,451	323,003	-9,448	-2.8%
Maintenance & Repairs	0	0	0	0	n/a
Utilities	0	192	0	-192	-100.0%
Insurance & Injuries	0	0	0	0	n/a
Safety & Security	0	0	0	0	n/a
General Business/Other	23,360	35,244	31,275	-3,969	-11.3%
Costs Transferred to Capital Projects	0	0	0	0	n/a
Inter Division Reimbursement	<u>0</u>	<u>0</u>	<u>0</u>	<u>0</u>	<u>n/a</u>
TOTAL OPERATING EXPENSES	<u>333,520</u>	<u>367,887</u>	<u>354,278</u>	<u>-13,609</u>	<u>-3.7%</u>
OPERATING INCOME/(LOSS)	-333,520	-367,887	-354,278	13,609	-3.7%
LESS: DIRECT CAPITAL	<u>0</u>	<u>0</u>	<u>0</u>	<u>0</u>	<u>n/a</u>
NET SURPLUS/(DEFICIT)	<u>-333,520</u>	<u>-367,887</u>	<u>-354,278</u>	<u>13,609</u>	<u>-3.7%</u>

**EQUAL EMPLOYMENT
OPPORTUNITY/DIVERSITY DEVELOPMENT
BRANCH**

DESCRIPTION

The Niagara Frontier Transportation Authority is committed to ensuring that all persons who are employed, seeking employment, or those individuals who are seeking contracts with the NFTA, are afforded equal opportunities.

The Equal Opportunity / Diversity Development branch is responsible for planning, developing, implementing and evaluating the Authority's Affirmative Action / Equal Employment Opportunity Programs. The department also administers the Disadvantaged Business Enterprises (DBE) in compliance with 49 CFR Part 26, Sub Part D, FTA Circulars 11.55.1, 1160.1, Executive Order 11246 and Affirmative Action Programs as required under Title VI of the Civil Rights Act of 1964. The department is also responsible for Authority-wide compliance with the Americans with Disabilities Act of 1990.

PROGRAM AND SERVICE OBJECTIVES

- Administer the Disadvantaged Business Enterprise (DBE) Certification Program and the Equal Employment Opportunity (EEO) Program.
- Monitor contracts for compliance with all federal and state requirements.
- As required, reports are filed with the Federal Aviation Administration, Federal Transit Administration and the New York State Department of Transportation.
- Provide branch managers and department heads with information pertaining to civil rights compliance.
- Monitor hiring and promotional activity to ensure that minorities and women are represented in all job groups.
- Investigate and resolve complaints of discrimination filed by employees of the NFTA and NFT Metro.

- Conduct civil rights, sexual harassment and Americans With Disabilities Act training classes.
- Fixed route mobility training to minimize usage of paratransit service.
- Ensure Authority-wide compliance with ADA of 1990 employment, facility and transportation service requirements.
- Act as a liaison with the disabled community via the Advisory Committee on the Disabled.

KEY PERFORMANCE INDICATORS

	<u>FYE 10 Actual</u>	<u>FYE 11 Original Budget</u>	<u>FYE 11 Current Estimate</u>	<u>FYE 12 Budget</u>
DBE Applications Processed	47	80	50	65
DBEs Certified	47	70	50	64
Civil Rights Complaints Filed - INTERNAL	21	0	22	0
Civil Rights Complaints Resolved-INTERNAL	21	0	22	0
Civil Rights Complaints Filed-EXTERNAL	3	0	5	0
Civil Rights Complaints Resolved- EXTERNAL	0	0	0	0
Sexual Harassment Complaints	2	0	0	0
ADA Complaints Filed - INTERNAL	33	0	12	0
ADA Complaints Resolved-INTERNAL	33	0	12	0

	FYE 10 <u>Actual</u>	FYE 11 <u>Original</u> <u>Budget</u>	FYE 11 <u>Current</u> <u>Estimate</u>	FYE 12 <u>Budget</u>
ADA Complaints Filed - EXTERNAL	0	0	0	0
ADA Complaints Resolved – EXTERNAL	0	0	0	0
Services for the Disabled:				
Complaints Filed	33	25	12	0
Commendations Filed	5	6	4	10
Complaints Resolved	33	20	12	0
Street Announcement Compliance	76%	100%	80%	100%
FTA DBE Goal	18%	18%	18%	18%
FTA DBE Goal Achieved	13%	18%	18%	18%
FAA DBE Goal	18%	18%	16%	17%
FAA DBE Goal Achieved	14%	18%	16%	17%
FAA Car Rental Concession Goal	10%	10%	10%	10%
FAA Non-Car Rental Concession Goal	10%	10%	10%	10%

NIAGARA FRONTIER TRANSPORTATION AUTHORITY
(ACCOUNTCO, ACCOUNTUNIT, ACCOUNT)
BUDGET WORKSHEETS - Fiscal Year 2011-12

Company 1 Niagara Frontier Transportation Authority
Division 31 AFFIRMATIVE ACTION
Department 0098 AFF. ACTION BRANCH ADMIN.

Account	Description	2009-10 Actual	2010-11 Budget	2010-11 Sept. YTD Actual	2011-12 Req Budget	VARIANCE From Budget
510	EMPLOYEE SALARIES	222,235	226,827	163,911	217,475	9,352-
515	EMPLOYEE BENEFITS	87,925	105,624	77,570	105,528	96-
534	TELEPHONE		192			192-
571	CONSULTANTS/OUTSIDE SERVICES	13,855	21,999	17,253	22,000	1
576	EMPLOYEE TRAVEL	1,130	2,000	16	925	1,075-
577	EMPLOYEE TRAINING		1,245			1,245-
578	POSTAGE	812	1,000	528	850	150-
580	GENERAL OFFICE	7,563	9,000	5,324	7,500	1,500-
TOTAL	EXPENSES	333,520	367,887	264,602	354,278	13,609-

31 AFFIRMATIVE ACTION
98 AFF. ACTION BRANCH ADMIN.

EMPLOYEE GROUP: PB-ALL

Job Description	Grade/Step	Base Salary	Increase Amount	Longevity Amount	Scheduled Amount
MANAGER, EEO/DIVERSITY	20	96,920			96,920
ADA/EEO ADMINISTRATOR	7	42,435		500	42,935
NON-REP Totals	2	139,355		500	139,855
COMPLIANCE SPEC	7 2	39,149	2,603		41,752
ADMINISTRATIVE ASST	4 2	31,700	1,668		33,368
UNION Totals	2	70,849	4,271		75,120
Department Totals	4	210,204	4,271	500	214,975

GENERAL COUNSEL

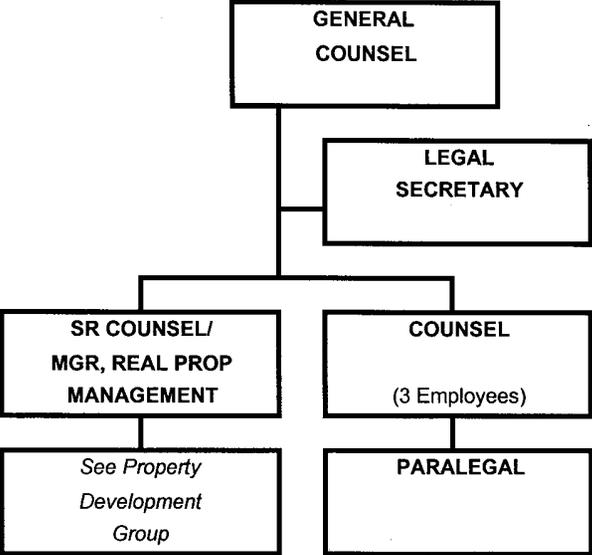

TOTAL EMPLOYEES 7

GENERAL COUNSEL
2010/11 ANNUAL BUDGET
VS
2011/12 ANNUAL BUDGET

	FY 09-10 ACTUAL	FY 10-11 BUDGET	FY 11-12 BUDGET	VARIANCE	%
OPERATING EXPENSES (Excl. Depr.)					
Personnel Services	876,030	932,437	904,823	-27,614	-3.0%
Maintenance & Repairs	0	0	0	0	n/a
Utilities	390	366	374	8	2.2%
Insurance & Injuries	0	0	0	0	n/a
Safety & Security	0	0	0	0	n/a
General Business/Other	115,110	130,470	132,930	2,460	1.9%
Costs Transferred to Capital Projects	0	0	0	0	n/a
Inter Division Reimbursement	<u>-215,653</u>	<u>-229,599</u>	<u>-290,642</u>	<u>-61,043</u>	<u>26.6%</u>
TOTAL OPERATING EXPENSES	<u>775,877</u>	<u>833,674</u>	<u>747,485</u>	<u>-86,189</u>	<u>-10.3%</u>
OPERATING INCOME/(LOSS)	-775,877	-833,674	-747,485	86,189	-10.3%
LESS: DIRECT CAPITAL	<u>0</u>	<u>0</u>	<u>0</u>	<u>0</u>	<u>n/a</u>
NET SURPLUS/(DEFICIT)	<u>-775,877</u>	<u>-833,674</u>	<u>-747,485</u>	<u>86,189</u>	<u>-10.3%</u>

GENERAL COUNSEL

DESCRIPTION

The office of General Counsel provides and/or administers all legal services for the NFTA and NFTM on civil and administrative matters. This includes representation of the NFTA and NFTM in negligence claims, negotiations with and proceedings involving state and federal agencies, arbitrations involving collective bargaining agreements or employee grievances, professional negligence, tort and contract claims, condemnation and relocation proceedings, negotiation of collective bargaining agreements, preparation of leases, releases, use and operating agreements, settlements and memoranda of understanding.

The office of General Counsel provides advice, opinions and counsel to the Board of Commissioners, the Executive Director, business center managers and staff on matters concerning labor and employment relations, environmental compliance and litigation, landlord-tenant and real property transactions, procurement and contracting issues, suretyship, risk management and insurance, municipal bonds and finance, secured transactions, commercial relationships, and corporate and legislative concerns.

Under the direction of the General Counsel, staff attorneys appear in state and federal trial and appellate courts and before arbitration panels and administrative agencies such as the New York State Department of Labor, the U.S. Environmental Protection Agency, the New York State Department of Transportation and the Federal Transit Administration. General Counsel attorneys draft proposed agency rules and administrative procedures, and pursue enforcement and collection of judgments for fare evasions and parking violations. Staff personnel manage the board agenda, prepare resolutions for consideration by the Board of Commissioners and assist and provide guidance to user departments and business centers on procurement and various other matters impacting the day-to-day and long range operations of NFTA and Metro. The General Counsel also oversees the functions of the Property Group.

PROGRAM AND SERVICE OBJECTIVES

- To provide thorough, timely and effective legal counsel to Authority management, its commissioners and officers.
- To effectively represent the Authority in all disputes, claims, litigation, and administrative proceedings.
- To continue preparation and updating of legal agreements consistent with federal and state requirements and as necessary to support Authority objectives.
- To effectively use outside legal services within budgeted allocations.
- To regularly review pending litigation files and determine reasonable settlement/reserve values.
- To provide contract administration services and guidance to the procurement and user departments involved in specialized procurements.
- To assist management in the updating, promulgation and implementation of various operational guidelines for procurement consistent with the needs of user departments, state and federal funding participants and applicable law.
- To provide legal advice and services to facilitate the acquisition of real property as required to implement project undertakings of the Authority.

NIAGARA FRONTIER TRANSPORTATION AUTHORITY
(ACCOUNTCO, ACCOUNTUNIT, ACCOUNT)
BUDGET WORKSHEETS - Fiscal Year 2011-12

Company 1 Niagara Frontier Transportation Authority
Division 32 GENERAL COUNSEL
Department 0098 GENERAL COUNSEL BRANCH ADMIN

Account	Description	2009-10 Actual	2010-11 Budget	2010-11 Sept. YTD Actual	2011-12 Req Budget	VARIANCE From Budget
510	EMPLOYEE SALARIES	629,257	638,425	470,410	611,358	27,067-
515	EMPLOYEE BENEFITS	246,770	294,012	217,086	293,465	547-
534	TELEPHONE	390	366	166	374	8
571	CONSULTANTS/OUTSIDE SERVICES	63,555	81,600	14,958	81,600	
576	EMPLOYEE TRAVEL	1,133	2,000	892	1,425	575-
577	EMPLOYEE TRAINING	1,105	1,870	1,045	1,105	765-
578	POSTAGE	1,893	2,000	1,340	2,000	
580	GENERAL OFFICE	47,423	43,000	35,969	46,800	3,800
592	DIVISION OPERATIONS	215,653-	229,599-	199,631-	290,642-	61,043-
TOTAL EXPENSES		775,873	833,674	542,235	747,485	86,189-

32 GENERAL COUNSEL
98 GENERAL COUNSEL BRANCH ADMIN

EMPLOYEE GROUP: PB-ALL

Job Description	Grade/Step	Base Salary	Increase Amount	Longevity Amount	Scheduled Amount
Acting, General Counsel	19 1	130,000			130,000
SR. COUNSEL/MANAGER RE	21 1	102,449		1,500	103,949
COUNSEL	19 1	91,907		1,500	93,407
COUNSEL	19 1	90,806	900		91,706
COUNSEL	19	90,806			90,806
PARALEGAL	8	47,140		500	47,640
LEGAL SECRETARY	5	40,000			40,000
NON-REP Totals	7	593,108	900	3,500	597,508
Department Totals	7	593,108	900	3,500	597,508

ENGINEERING

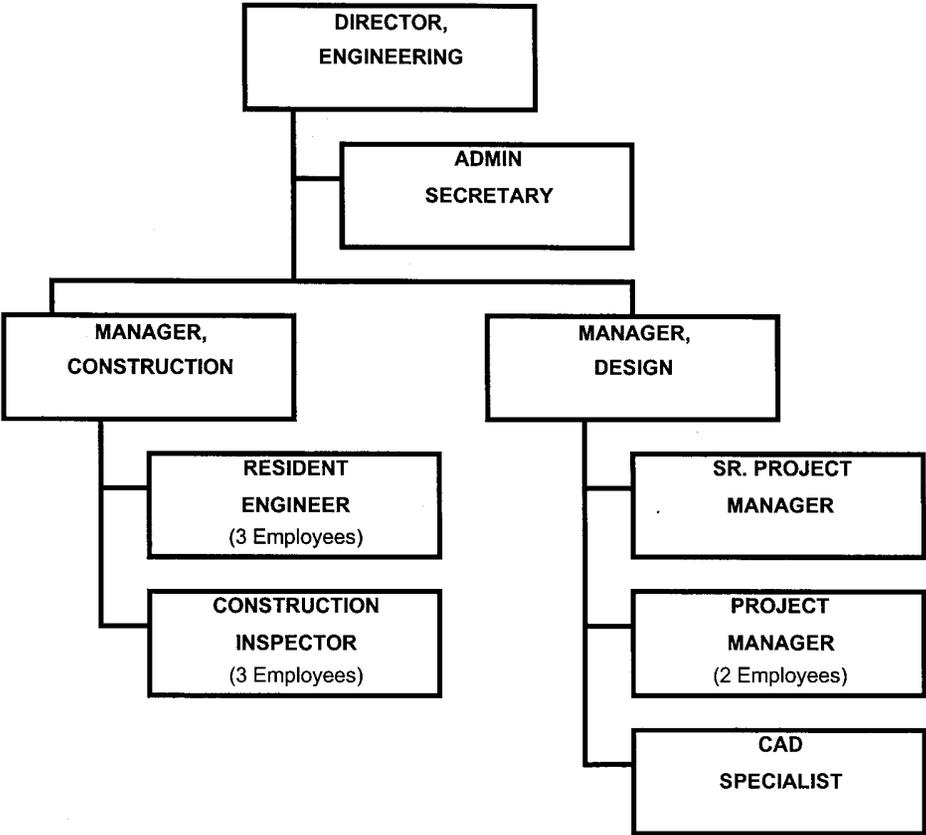

TOTAL EMPLOYEES 14

ENGINEERING
2010/11 ANNUAL BUDGET
VS
2011/12 ANNUAL BUDGET

	FY 09-10 ACTUAL	FY 10-11 BUDGET	FY 11-12 BUDGET	VARIANCE	%
OPERATING EXPENSES (Excl. Depr.)					
Personnel Services	1,866,837	1,771,295	1,658,310	-112,985	-6.4%
Maintenance & Repairs	10,886	7,000	8,000	1,000	14.3%
Utilities	5,091	6,629	4,536	-2,093	-31.6%
Insurance & Injuries	76	0	0	0	n/a
Safety & Security	0	0	0	0	n/a
General Business/Other	63,163	87,110	62,116	-24,994	-28.7%
Costs Transferred to Capl Proj	-1,557,642	-1,417,876	-1,260,755	157,121	-11.1%
Inter Division Reimbursement	<u>-67,985</u>	<u>-90,499</u>	<u>-76,499</u>	<u>14,000</u>	<u>-15.5%</u>
TOTAL OPERATING EXPENSES	<u>320,426</u>	<u>363,659</u>	<u>395,708</u>	<u>32,049</u>	<u>8.8%</u>
OPERATING INCOME/(LOSS)	-320,426	-363,659	-395,708	-32,049	8.8%
LESS: DIRECT CAPITAL	<u>4,057</u>	<u>22,000</u>	<u>0</u>	<u>-22,000</u>	<u>-100.0%</u>
NET SURPLUS/(DEFICIT)	<u>-324,483</u>	<u>-385,659</u>	<u>-395,708</u>	<u>-10,049</u>	<u>2.6%</u>

ADMINISTRATION

DESCRIPTION

The Administration Department is responsible for the management and administration of the Engineering Branch, which includes the Design, and Construction Departments. The Administration Department interacts with other support service branches to ensure consistency with the goals and objectives of the NFTA Business Centers.

PROGRAM AND SERVICE OBJECTIVES

- Provide cost effective project management including engineering design, and construction services.
- Manage NFTA energy management programs.
- Implement the NFIA Airport Improvement Program projects.
Total program cost - \$30.2M
- Implement the BNIA Airport Improvement Program projects.
Total program cost - \$7.3M
- Implement the LRV Rebuild program
Total program cost - \$41M
- Manage BNIA Residential Noise Compatibility 10-year Program - \$84M

NIAGARA FRONTIER TRANSPORTATION AUTHORITY
(ACCOUNTCO, ACCOUNTUNIT, ACCOUNT)
BUDGET WORKSHEETS - Fiscal Year 2011-12

Company 1 Niagara Frontier Transportation Authority
Division 33 ENGINEERING
Department 0098 BRANCH ADMINISTRATION

Account	Description	2009-10 Actual	2010-11 Budget	2010-11 Sept. YTD Actual	2011-12 Req Budget	VARIANCE From Budget
510	EMPLOYEE SALARIES	148,830	146,084	108,791	148,965	2,881
515	EMPLOYEE BENEFITS	58,032	67,807	51,226	72,247	4,440
524	AUTOMOTIVE	10,886	7,000	6,747	8,000	1,000
534	TELEPHONE	616	622	362	682	60
541	INSURANCE	76		44		
575	PRINTING & ADVERTISING	1,201	3,999	107	1,200	2,799-
576	EMPLOYEE TRAVEL	324	500	145	500	
577	EMPLOYEE TRAINING					
578	POSTAGE	383	500	369	500	
580	GENERAL OFFICE	38,314	38,000	20,689	33,000	5,000-
591	PROJECTS	121,870-	141,780-	77,192-	120,000-	21,780
592	DIVISION OPERATIONS	9,956-	6,499-	12,156-	6,499-	
TOTAL	EXPENSES	126,836	116,233	99,132	138,595	22,362

33 ENGINEERING
98 BRANCH ADMINISTRATION

EMPLOYEE GROUP: PB-ALL

Job Description	Grade/Step	Base Salary	Increase Amount	Longevity Amount	Scheduled Amount
DIRECTOR, ENGINEERING	23	106,292		500	106,792
NON-REP Totals	1	106,292		500	106,792
ADMINISTRATIVE SECRETA	5 5	36,883	3,490		40,373
UNION Totals	1	36,883	3,490		40,373
Department Totals	2	143,175	3,490	500	147,165

DESIGN

DESCRIPTION

The Design Department provides and manages design development of capital projects and studies consistent with the goals and objectives of the NFTA Business Centers. The services include the establishment of Authority design objectives, criteria and standards, ensuring that project designs comply with technical building code regulations and development of project scopes and budgets. In addition, the department prepares cost estimates, capital and planning budgets, reports, and studies. The department also reviews and approves contractor shop drawings, requests for tenant modifications, and private development plans and specifications. The management of consultants includes initiating and concluding the selection process, reviewing and approving payments, and contract closeout. The Design Department provides engineering expertise and support for other departments and branches and is instrumental in development of the Authority-wide Five Year Capital Plan, FAA Airport Capital Improvement Programs, assisting the Business Center with the BNIA Noise Compatibility Program, and providing direct assistance in managing the LRRT Light Rail Vehicle Rebuild project.

PROGRAM AND SERVICE OBJECTIVES

- Initiate implementation of capital projects in a cost and time effective manner.
- Each capital project is assigned an implementation schedule with milestone dates and cashflow projections. The actual costs, cashflows, and milestone dates are monitored to assess overall performance.

KEY PERFORMANCE INDICATORS

	FYE 10 <u>Actual</u>	FYE 11 <u>Original</u> <u>Budget</u>	FYE 11 <u>Current</u> <u>Estimate</u>	FYE 12 <u>Budget</u>
Number of capital projects requested by Business Centers	23	36	23	23
Total dollar value of projects requested by Business Centers (000's)	\$71,090	\$46,463	\$60,210	\$38,637
Percent of projects which the design costs were within acceptable industry standards (As a % of construction cost)	100%	100%	100%	N/A
Percentage of projects designed on schedule	100%	100%	100%	N/A
Percentage of staff salaries charged to projects	61%	65%	65%	N/A

NIAGARA FRONTIER TRANSPORTATION AUTHORITY
(ACCOUNTCO, ACCOUNTUNIT, ACCOUNT)
BUDGET WORKSHEETS - Fiscal Year 2011-12

Company 1 Niagara Frontier Transportation Authority
Division 33 ENGINEERING
Department 0070 DESIGN

Account	Description	2009-10 Actual	2010-11 Budget	2010-11 Sept. YTD Actual	2011-12 Req Budget	VARIANCE From Budget
510	EMPLOYEE SALARIES	497,172	508,472	368,292	415,556	92,916-
515	EMPLOYEE BENEFITS	196,260	233,489	170,321	202,299	31,190-
571	CONSULTANTS/OUTSIDE SERVICES	21,728	40,000	13,810	25,700	14,300-
577	EMPLOYEE TRAINING	1,191	3,332	725	1,191	2,141-
591	PROJECTS	494,632-	517,756-	330,955-	396,679-	121,077
592	DIVISION OPERATIONS	17,690-	8,999-	74,015-	20,000-	11,001-
TOTAL EXPENSES		204,029	258,538	148,178	228,067	30,471-

33 ENGINEERING
70 DESIGN

EMPLOYEE GROUP: PB-ALL

Job Description	Grade/Step	Base Salary	Increase Amount	Longevity Amount	Scheduled Amount
Manager, Design	18	91,080			91,080
SR. PROJECT MANAGER	17	84,872			84,872
PROJECT MANAGER	16	81,282			81,282
PROJECT MANAGER	16	80,854			80,854
NON-REP Totals	4	338,088			338,088
CAD SPECIALIST	12 6	69,112	3,496	1,400	74,008
UNION Totals	1	69,112	3,496	1,400	74,008
Department Totals	5	407,200	3,496	1,400	412,096

CONSTRUCTION

DESCRIPTION

The Construction Department is responsible for construction management of all capital improvement projects. The department ensures that projects are constructed and completed within budget and schedule consistent with the goals and objectives of the NFTA Business Centers. The Construction Department also manages Professional Services Contracts. The primary purpose of the department is to assure contract compliance with contract documents and to ensure full reimbursement of all grant eligible costs from funding agencies.

Liaison with Federal and State funding agencies and various other jurisdictional agencies and public and private utilities, Authority tenants, and adjacent property and business owners is required.

The department also provides coordination between contractors and all other Authority Support Service branches including assisting with implementation of the BNIA Noise Compatibility Program.

PROGRAM AND SERVICE OBJECTIVES

- Provide cost effective construction monitoring/management services consistent with the requirements of the Business Centers (i.e., scope, budget, schedule, and coordination).
- Ensure contract compliance and monitor project quality control.
- Management of construction projects which results in full cost reimbursement from the appropriate funding agencies.
- Ensure that the costs of inspection/management services are within acceptable industry standards.
- Ensure contract and project closeouts in a timely manner.

KEY PERFORMANCE INDICATORS

	FYE 10 <u>Actual</u>	FYE 11 <u>Original Budget</u>	FYE 11 <u>Current Estimate</u>	FYE 12 <u>Budget Estimated</u>
Number of projects under construction	34	40	36	28
Value of projects under construction (000's)	\$147,169	\$112,439	\$80,725	\$84,935
Percent of projects completed on time	88%	100%	100%	N/A
Percent of projects completed within budget	91%	100%	100%	N/A
Percent of projects completed with a total change order amount within acceptable industry standards	100%	100%	100%	N/A
Percent of projects which receive full reimbursement from appropriate funding agencies	100%	100%	100%	N/A
Total dollar value of non-reimbursement	\$0	\$0	\$0	N/A
Percent of projects that exceed acceptable industry standards for cost of providing construction inspection services	0%	0%	0%	N/A

NIAGARA FRONTIER TRANSPORTATION AUTHORITY
(ACCOUNTCO, ACCOUNTUNIT, ACCOUNT)
BUDGET WORKSHEETS - Fiscal Year 2011-12

Company 1 Niagara Frontier Transportation Authority
Division 33 ENGINEERING
Department 0078 CONSTRUCTION

Account	Description	2009-10 Actual	2010-11 Budget	2010-11 Sept. YTD Actual	2011-12 Req Budget	VARIANCE From Budget
510	EMPLOYEE SALARIES	702,933	561,840	417,073	560,762	1,078-
515	EMPLOYEE BENEFITS	263,597	253,600	183,479	258,481	4,881
534	TELEPHONE	4,475	6,006	2,572	3,854	2,152-
577	EMPLOYEE TRAINING		779			779-
580	GENERAL OFFICE	21			25	25
591	PROJECTS	941,140-	758,338-	528,371-	744,076-	14,262
592	DIVISION OPERATIONS	40,338-	74,999-	25,180-	50,000-	24,999
TOTAL EXPENSES		10,452-	11,112-	49,573	29,046	40,158

33 ENGINEERING
78 CONSTRUCTION

EMPLOYEE GROUP: PB-ALL

Job Description	Grade/Step		Base Salary	Increase Amount	Longevity Amount	Scheduled Amount
MGR. OF CONSTRUCTION	17	1	75,231			75,231
NON-REP Totals		1	75,231			75,231
RESIDENT ENGINEER	12	6	69,112	3,496	1,400	74,008
RESIDENT ENGINEER	12	5	63,203	6,237	500	69,940
RESIDENT ENGINEER	12	4	60,442	5,959		66,401
CONSTRUCTION INSPECTOR	10	6	59,423	3,006	1,100	63,529
CONSTRUCTION INSPECTOR	10	5	54,427	5,311		59,738
CONSTRUCTION INSPECTOR	10	2	49,188	3,327		52,515
UNION Totals		6	355,795	27,336	3,000	386,131
Department Totals		7	431,026	27,336	3,000	461,362

FY 2011 / 2012 THROUGH 2015 / 2016

CAPITAL PROJECTS

ENGINEERING

PROJECT TITLE	PROJECT NUMBER	PRTY CL	JUST. CL	FUND SOURCE	TOTAL PROJECT BUDGET	PROJECT LIFE ACTUAL AS OF 7/19/10	TOTAL FORECASTED SPENDING 7/20/10	FISCAL YEAR 2011/2012	FISCAL YEAR 2012/2013	FISCAL YEAR 2013/2014	FISCAL YEAR 2014/2015	FISCAL YEAR 2015/2016	OUT YEARS
ENGINEERING													
ENHANCED GPS SURVEY EQUIPMENT ANTENNA	--	1	NI	NFTA	\$2,500	\$0	\$2,500	\$0	\$0	\$0	\$0	\$0	\$0
COLOR INKJET PLOTTER REPLACEMENT	--	2	NR	NFTA	\$10,000	\$0	\$10,000	\$0	\$0	\$0	\$0	\$0	\$0
CONSTRUCTION VEHICLE REPLACEMENT	--	3	NR	NFTA	\$57,500	\$0	\$0	\$0	\$10,500	\$11,000	\$11,500	\$12,000	\$12,500
COLOR COPIER REPLACEMENT	--	4	NR	NFTA	\$20,000	\$0	\$0	\$0	\$0	\$0	\$20,000	\$0	\$0
XEROX 510 CAD PLOTTER REPLACEMENT	--	5	NR	NFTA	\$31,900	\$0	\$0	\$0	\$0	\$0	\$0	\$31,900	\$0

NFTA \$121,900 \$0 \$12,500 \$0 \$10,500 \$11,000 \$31,500 \$43,900 \$12,500

PUBLIC AFFAIRS

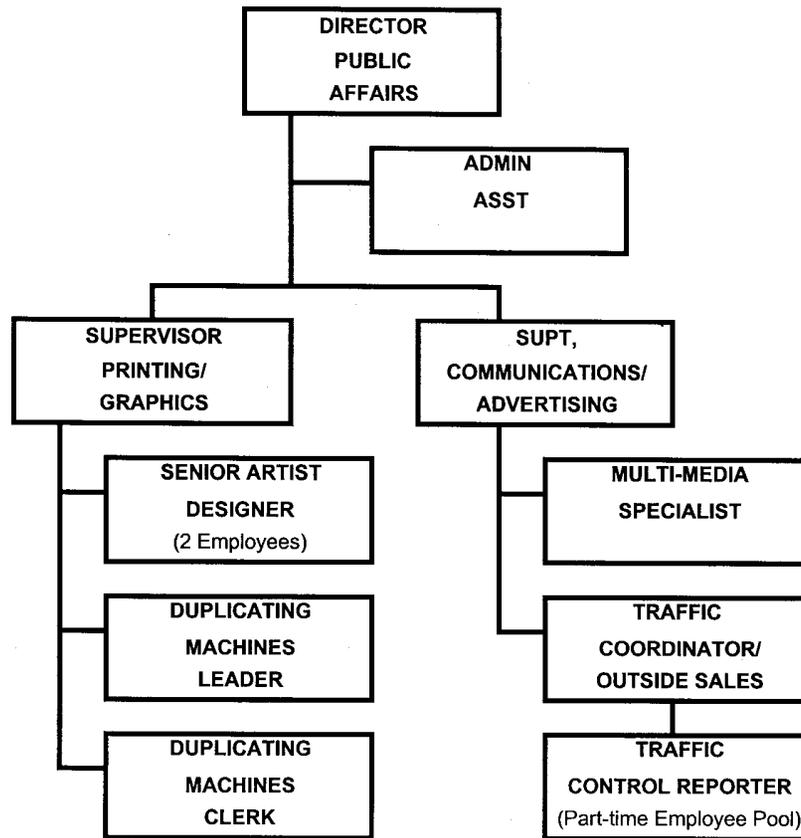

TOTAL EMPLOYEES:

	FT	PT	Total
NFTA	8	0	8
Metro	2	1	3
Total	10	1	11

PUBLIC AFFAIRS
2010/11 ANNUAL BUDGET
VS
2011/12 ANNUAL BUDGET

	FY 09-10 ACTUAL	FY 10-11 BUDGET	FY 11-12 BUDGET	VARIANCE	%
OPERATING EXPENSES (Excl. Depr.)					
Personnel Services	839,137	911,574	919,177	7,603	0.8%
Maintenance & Repairs	0	0	0	0	n/a
Utilities	404	490	450	-40	-8.2%
Insurance & Injuries	0	0	0	0	n/a
Safety & Security	0	0	0	0	n/a
General Business/Other	162,596	158,934	156,209	-2,725	-1.7%
Costs Transferred to Capital Projects	0	0	0	0	n/a
Inter Division Reimbursement	<u>-69,342</u>	<u>-72,559</u>	<u>-73,584</u>	<u>-1,025</u>	<u>1.4%</u>
TOTAL OPERATING EXPENSES	<u>932,795</u>	<u>998,439</u>	<u>1,002,252</u>	<u>3,813</u>	<u>0.4%</u>
OPERATING INCOME/(LOSS)	-932,795	-998,439	-1,002,252	-3,813	0.4%
LESS: DIRECT CAPITAL	<u>0</u>	<u>2,000</u>	<u>0</u>	<u>-2,000</u>	<u>-100.0%</u>
NET SURPLUS/(DEFICIT)	<u>-932,795</u>	<u>-1,000,439</u>	<u>-1,002,252</u>	<u>-1,813</u>	<u>0.2%</u>

PUBLIC AFFAIRS

DESCRIPTION

The Public Affairs Department provides support with public relations, advertising, communications, graphic production, web site support, community relations, and marketing materials to all business centers within the NFTA. Services provided by the department include but are not limited to marketing, advertising, public relations, printing, media, community relations, graphic design and production.

Public Affairs is responsible for the dissemination of pertinent and vital information to the media, the community and within the authority. This is accomplished by complying with media requests for interviews and information, through communication campaigns to increase the awareness of NFTA's public transportation services, to generate revenues, to promote a positive corporate image and by publishing the authority's in-house newspaper the *Transporter* for employees and community stakeholders.

In addition, the department is responsible for the preparation, design and production of collateral and marketing support materials used by various departments within the NFTA. The in-house print and sign departments produce the majority of the materials and provide assistance in the production of signage used throughout the authority. The majority of signage work involves bus stop additions, vehicle detailing, bus shelter advertising, Metro Rail station signage, replacements and modifications.

PERFORMANCE AND SERVICE OBJECTIVES

- Design and produce a variety of marketing support materials for the various business centers within the NFTA
- Provide communication/marketing services to all business centers within the authority
- Prepare and produce all Metro timetables, *Metro Reporter*, route maps, updating service information with quarterly changes
- Help to maintain a consistent corporate identity for the NFTA
- Continue to improve the effectiveness of the public relations programs using established public relations practices and techniques
- Gain support from the Buffalo Niagara region for NFTA's public transportation initiatives through participation in various community events and activities
- Communicate NFTA operational policies and changes
- Write and produce the NFTA's in-house publication *Transporter* as a means of informing NFTA associates and community stakeholders about happenings within the authority
- Maintain and update the NFTA's websites

- Assist with the publishing of the NFTA's Annual Financial Report
- Respond in a timely manner to inquiries from the media relating to matters concerning the NFTA

KEY PERFORMANCE INDICATORS

	FYE 10 <u>Actual</u>	FYE 11 <u>Original Budget</u>	FYE 11 <u>Current Estimate</u>	FYE 12 <u>Budget</u>
Media Awareness (existing customers)	90%	90%	90%	90%
Number of Releases	55	52	52	52
Number of Events	20	16	15	20
Number of Graphics Projects Completed	172	140	160	160
Number of Hours On Vinyl Cutter	675	600	620	600
Produced Poster Signage for Outdoor Displays	137	160	175	160
Produce editions of the <i>Transporter</i>	4	4	4	4
Produce and NFTA Annual Financial Report	1	1	1	1

NIAGARA FRONTIER TRANSPORTATION AUTHORITY
(ACCOUNTCO, ACCOUNTUNIT, ACCOUNT)
BUDGET WORKSHEETS - Fiscal Year 2011-12

Company 1 Niagara Frontier Transportation Authority
Division 36 MARKETING AND REVENUE DEVOLP.
Department 0098 BRANCH ADMINISTRATION

Account	Description	2009-10 Actual	2010-11 Budget	2010-11 Sept. YTD Actual	2011-12 Req Budget	VARIANCE From Budget
510	EMPLOYEE SALARIES	302,779	316,328	236,951	311,950	4,378-
515	EMPLOYEE BENEFITS	119,735	145,375	109,659	150,994	5,619
534	TELEPHONE	404	490	352	450	40-
571	CONSULTANTS/OUTSIDE SERVICES		950		375	575-
575	PRINTING & ADVERTISING	10,529	14,200	4,329	10,400	3,800-
576	EMPLOYEE TRAVEL	393	300	83	250	50-
577	EMPLOYEE TRAINING	2,950	30		300	270
578	POSTAGE	646	806	37	600	206-
580	GENERAL OFFICE	3,268	6,345	2,634	4,200	2,145-
592	DIVISION OPERATIONS	69,242-	71,559-	61,427-	72,584-	1,025-
TOTAL	EXPENSES	371,462	413,265	292,618	406,935	6,330-

36 MARKETING AND REVENUE DEVOLP.
98 BRANCH ADMINISTRATION

EMPLOYEE GROUP: PB-ALL

Job Description	Grade/Step	Base Salary	Increase Amount	Longevity Amount	Scheduled Amount
DIRECTOR, PUBLIC AFFAI	21	99,818		700	100,518
SUPERINTENDENT, COMM/A	15 1	62,767		900	63,667
MULTIMEDIA SPECIALIST	12	56,855			56,855
TRAFFIC COORD/OUTSIDE	10	48,014		700	48,714
NON-REP Totals	4	267,454		2,300	269,754
ADMINISTRATIVE ASSISTA	4 5	35,405	2,291		37,696
UNION Totals	1	35,405	2,291		37,696
Department Totals	5	302,859	2,291	2,300	307,450

NIAGARA FRONTIER TRANSPORTATION AUTHORITY
(ACCOUNTCO, ACCOUNTUNIT, ACCOUNT)
BUDGET WORKSHEETS - Fiscal Year 2011-12

Company 1 Niagara Frontier Transportation Authority
Division 36 MARKETING AND REVENUE DEVOLP.
Department 0045 BUSINESS DEVELOPMENT

Account	Description	2009-10 Actual	2010-11 Budget	2010-11 Sept. YTD Actual	2011-12 Req Budget	VARIANCE From Budget
510	EMPLOYEE SALARIES	168,998	172,139	131,041	174,277	2,138
515	EMPLOYEE BENEFITS	66,792	78,876	60,072	83,245	4,369
575	PRINTING & ADVERTISING	14,446	16,999	16,043	11,900	5,099-
576	EMPLOYEE TRAVEL		245		100	145-
580	GENERAL OFFICE	72		162		
592	DIVISION OPERATIONS	99-	999-	2,152-	1,000-	1-
TOTAL EXPENSES		250,209	267,260	205,166	268,522	1,262

36 MARKETING AND REVENUE DEVOLP.
45 BUSINESS DEVELOPMENT

EMPLOYEE GROUP: PB-ALL

Job Description	Grade/Step		Base Salary	Increase Amount	Longevity Amount	Scheduled Amount
SUPV. PRINTING/GRAPHIC	14	1	65,555		1,100	66,655
NON-REP Totals		1	65,555		1,100	66,655
SR. ARTIST DESIGNER	7	6	47,008	2,378	1,750	51,136
SR. ARTIST DESIGNER	7	6	47,008	2,378	1,400	50,786
UNION Totals		2	94,016	4,756	3,150	101,922
Department Totals		3	159,571	4,756	4,250	168,577

NIAGARA FRONTIER TRANSPORTATION AUTHORITY
(ACCOUNTCO, ACCOUNTUNIT, ACCOUNT)
BUDGET WORKSHEETS - Fiscal Year 2011-12

Company 2 NFT Metro System, Inc.
Division 36 MARKETING AND REVENUE DEVELOP
Department 0043 PRINT SHOP

Account	Description	2009-10 Actual	2010-11 Budget	2010-11 Sept. YTD Actual	2011-12 Req Budget	VARIANCE From Budget
514	GEN & ADMIN SALARY & WAGES	107,220	117,805	85,326	116,615	1,190-
515	EMPLOYEE BENEFITS	73,600	81,049	60,676	82,096	1,047
571	CONSULTANTS/OUTSIDE SERVICES	74,228	76,059	60,860	77,084	1,025
580	GENERAL OFFICE	56,053	43,000	44,871	51,000	8,000
TOTAL	EXPENSES	311,101	317,913	251,733	326,795	8,882

36 MARKETING AND REVENUE DEVELOP
 43 PRINT SHOP

EMPLOYEE GROUP: PB-ALL

Job Description	Grade/Step	Base Salary	Increase Amount	Longevity Amount	Scheduled Amount
PT TRAFFIC CENTRAL REP		11,640	344		11,984
NON-REP Totals	1	11,640	344		11,984
DUPLICATING MACHINES L	A 0	45,323		1,500	46,823
DUPLICATING MACHINES C	E 0	43,908		300	44,208
UNION Totals	2	89,231		1,800	91,031
Department Totals	3	100,871	344	1,800	103,015

HUMAN RESOURCES

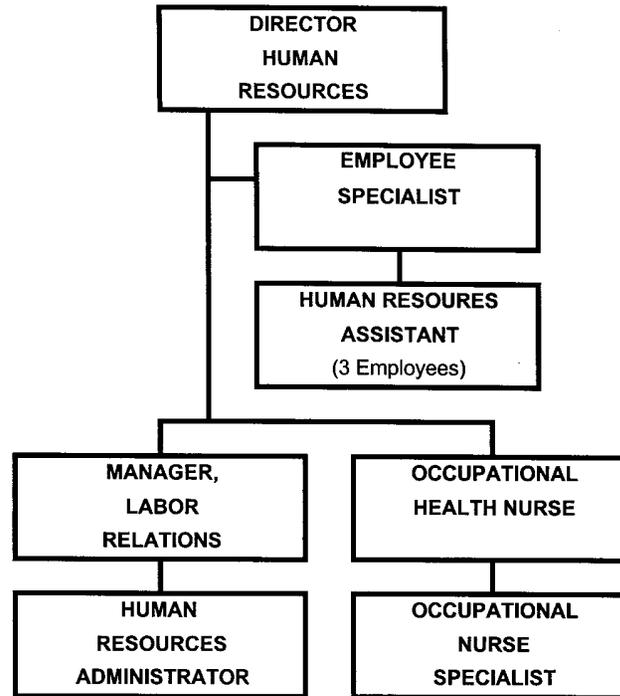

TOTAL EMPLOYEES

NFTA	8
Metro	1
Total	9

HUMAN RESOURCES
2010/11 ANNUAL FORECAST
VS
2011/12 ANNUAL BUDGET

	FY 09-10 ACTUAL	FY 10-11 BUDGET	FY 11-12 BUDGET	VARIANCE	%
OPERATING EXPENSES (Excl. Depr.)					
Personnel Services	1,566,868	1,590,880	1,278,542	-312,338	-19.6%
Maintenance & Repairs	0	0	0	0	n/a
Utilities	-114	1,532	0	-1,532	-100.0%
Insurance & Injuries	0	0	0	0	n/a
Safety & Security	0	0	0	0	n/a
General Business/Other	650,604	608,478	545,500	-62,978	-10.4%
Costs Transferred to Capital Projects	0	0	0	0	n/a
Inter Division Reimbursement	<u>-746,900</u>	<u>-776,390</u>	<u>-633,510</u>	<u>142,880</u>	<u>-18.4%</u>
TOTAL OPERATING EXPENSES	<u>1,470,458</u>	<u>1,424,500</u>	<u>1,190,532</u>	<u>-233,968</u>	<u>-16.4%</u>
OPERATING INCOME/(LOSS)	-1,470,458	-1,424,500	-1,190,532	233,968	-16.4%
LESS: DIRECT CAPITAL	<u>1,187</u>	<u>0</u>	<u>0</u>	<u>0</u>	<u>n/a</u>
NET SURPLUS/(DEFICIT)	<u>-1,471,645</u>	<u>-1,424,500</u>	<u>-1,190,532</u>	<u>233,968</u>	<u>-16.4%</u>

HUMAN RESOURCES

DESCRIPTION

The branch is responsible for developing integrated human resource programs that provide cost effective benefits, effective and diversified staffing, positive employee climate, training opportunities, and compensation programs that motivate and reward performance. Provides services related to labor relations including negotiating collective bargaining agreements, investigating and resolving grievances, participating in arbitrations, PERB and other legal proceedings, and coordinating and participating in all labor-management activities. Administers programs in conjunction with Federal Regulations governing drug and alcohol testing, and medical certification in accordance with Motor Vehicle and Traffic Laws.

KEY PERFORMANCE INDICATORS

	<u>FYE 10 Actual</u>	<u>FYE 11 Original Budget</u>	<u>FYE 11 Current Estimate</u>	<u>FYE 12 Budget</u>
Labor contracts negotiated	10	13	12	13

PROGRAM AND SERVICE OBJECTIVES

- Implement programs/initiatives that provide cost effective benefits, effective staffing, personnel development, diversity and training.
- Develop positive union/management relationships that encourage mutual respect and common approaches to labor and business issues.
- Successfully conclude labor contract negotiations within established bargaining parameters and in a timely manner.
- Review existing benefit plans for effectiveness and appropriate cost/benefit relationships.
- Develop and obtain Board approval on bargaining strategy for contract negotiations.
- Develop with business directors, organization plans that minimize costs while upgrading talent by promotion, replacement and external recruiting.

NIAGARA FRONTIER TRANSPORTATION AUTHORITY
(ACCOUNTCO, ACCOUNTUNIT, ACCOUNT)
BUDGET WORKSHEETS - Fiscal Year 2011-12

Company 1 Niagara Frontier Transportation Authority
Division 38 HUMAN RESOURCES
Department 0098 BRANCH ADMINISTRATION

Account	Description	2009-10 Actual	2010-11 Budget	2010-11 Sept. YTD Actual	2011-12 Req Budget	VARIANCE From Budget
510	EMPLOYEE SALARIES	569,667	553,917	384,858	431,886	122,031-
515	EMPLOYEE BENEFITS	213,767	241,523	168,721	207,385	34,138-
534	TELEPHONE	57-	766			766-
571	CONSULTANTS/OUTSIDE SERVICES	247,879	229,999	162,266	218,200	11,799-
575	PRINTING & ADVERTISING		500	2,603	500	
576	EMPLOYEE TRAVEL	129	100	235	100	
577	EMPLOYEE TRAINING	10,855	23,843	352	5,000	18,843-
578	POSTAGE	3,788	5,999	2,959	4,300	1,699-
580	GENERAL OFFICE	34,407	23,798	25,774	22,650	1,148-
589	OTHER OPERATING EXPENSES	28,244	20,000	17,723	22,000	2,000
592	DIVISION OPERATIONS	373,450-	388,195-	286,136-	316,755-	71,440
TOTAL	EXPENSES	735,229	712,250	479,355	595,266	116,984-

38 HUMAN RESOURCES
98 BRANCH ADMINISTRATION

EMPLOYEE GROUP: PB-ALL

Job Description	Grade/Step	Base Salary	Increase Amount	Longevity Amount	Scheduled Amount
DIRECTOR, HUMAN RESOUR	23	96,500			96,500
Human Resources Admini	7 1	58,699		1,800	60,499
OCCUPATIONAL HEALTH NU	9	52,280		700	52,980
EMPLOYEE SPEC	13	51,800			51,800
OCCUPATIONAL NURSE SPE	7	46,349			46,349
HUMAN RESOURCES ASSIST	5	38,123		700	38,823
HUMAN RESOURCES ASSIST	5	38,113		700	38,813
HUMAN RESOURCES ASSIST	5	35,122		500	35,622
NON-REP Totals	8	416,986		4,400	421,386
Department Totals	8	416,986		4,400	421,386

NIAGARA FRONTIER TRANSPORTATION AUTHORITY
(ACCOUNTCO, ACCOUNTUNIT, ACCOUNT)
BUDGET WORKSHEETS - Fiscal Year 2011-12

Company 2 NFT Metro System, Inc.
Division 38 HUMAN RESOURCES
Department 0024 PERSONNEL

Account	Description	2009-10 Actual	2010-11 Budget	2010-11 Sept. YTD Actual	2011-12 Req Budget	VARIANCE From Budget
514	GEN & ADMIN SALARY & WAGES	77,621	79,164	60,671	79,163	1-
515	EMPLOYEE BENEFITS	52,755	54,464	42,023	55,730	1,266
571	CONSULTANTS/OUTSIDE SERVICES	404,859	426,195	308,589	354,131	72,064-
577	EMPLOYEE TRAINING		197			197-
580	GENERAL OFFICE	2,052-		708-	1,570-	1,570-
592	DIVISION OPERATIONS	87,674-	87,654-	68,925-	88,194-	540-
TOTAL EXPENSES		445,509	472,366	341,650	399,260	73,106-

38 HUMAN RESOURCES
24 PERSONNEL

EMPLOYEE GROUP: PB-ALL

Job Description	Grade/Step	Base Salary	Increase Amount	Longevity Amount	Scheduled Amount
Manager, Labor Relatio	17	79,163			79,163
NON-REP Totals	1	79,163			79,163
Department Totals	1	79,163			79,163

FINANCE & ADMINISTRATION

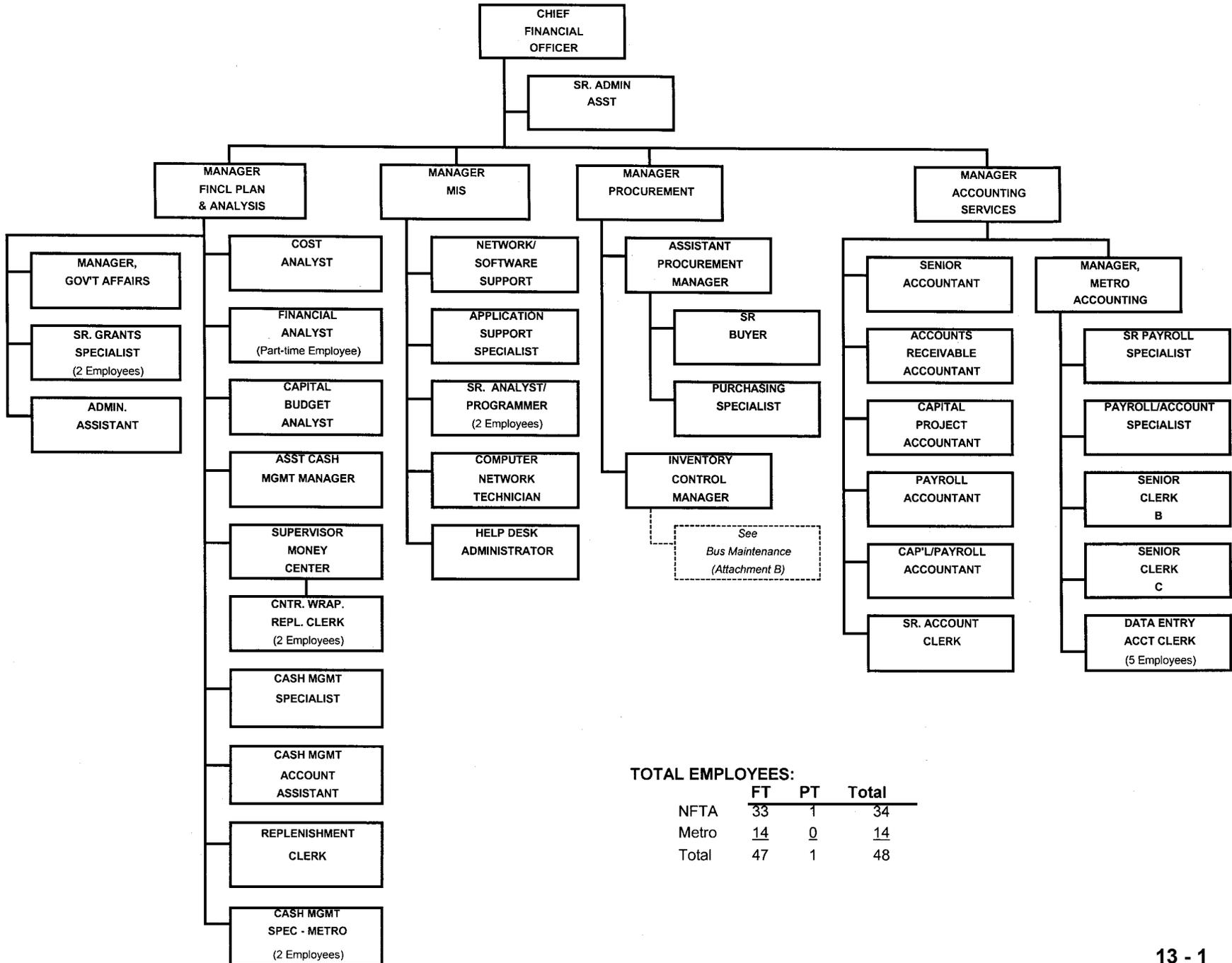

TOTAL EMPLOYEES:

	FT	PT	Total
NFTA	33	1	34
Metro	14	0	14
Total	47	1	48

FINANCE & ADMINISTRATION
2010/11 ANNUAL BUDGET
VS
2011/12 ANNUAL BUDGET

	FY 09-10 ACTUAL	FY 10-11 BUDGET	FY 11-12 BUDGET	VARIANCE	%
OPERATING EXPENSES (Excl. Depr.)					
Personnel Services	4,227,096	4,564,818	4,122,448	-442,370	-9.7%
Maintenance & Repairs	214,516	179,999	200,401	20,402	11.3%
Utilities	33,812	47,562	41,091	-6,471	-13.6%
Insurance & Injuries	0	0	0	0	n/a
Safety & Security	0	0	0	0	n/a
General Business/Other	2,331,010	2,482,151	2,349,626	-132,525	-5.3%
Costs Transferred to Capital Projects	-240,724	-209,929	-215,183	-5,254	2.5%
Inter Division Reimbursement	<u>-581,596</u>	<u>-497,472</u>	<u>-530,356</u>	<u>-32,884</u>	<u>6.6%</u>
TOTAL OPERATING EXPENSES	<u>5,984,114</u>	<u>6,567,129</u>	<u>5,968,027</u>	<u>-599,102</u>	<u>-9.1%</u>
OPERATING INCOME/(LOSS)	-5,984,114	-6,567,129	-5,968,027	599,102	-9.1%
LESS: DIRECT CAPITAL	<u>91,363</u>	<u>121,960</u>	<u>259,900</u>	<u>137,940</u>	<u>113.1%</u>
NET SURPLUS/(DEFICIT)	<u>-6,075,477</u>	<u>-6,689,089</u>	<u>-6,227,927</u>	<u>461,162</u>	<u>-6.9%</u>

GOVERNMENT AFFAIRS DEPARTMENT

DESCRIPTION

The principal mission of the Government Affairs department is to secure appropriate financial resources to fund the capital and operating needs of NFTA Business Centers.

PROGRAM AND SERVICE OBJECTIVES

The functions of the Government Affairs department include:

- Identify appropriate funding sources to satisfy Business Center funding needs.
- Perform administrative and legislative liaison tasks to facilitate obtaining funding.
- Assist program/project planning to maximize funding eligibility.
- Assist budget planning to optimize grant funding opportunities.
- Complete grantor agency requirements by preparing and submitting applications to secure approval and receipt of funds.
- Assure project management compliance with grantor rules, regulations, and grant closeout requirements.
- Communicate timely and accurate information to legislators in response to administrative and legislative initiatives.
- Represent NFTA funding interests in regional project planning.
- Communicate timely and accurate funding and project status information to NFTA policy makers and business managers.

PERFORMANCE MEASUREMENTS

- Grants awarded.
- Funds received to permit project implementation within budget timeframe and maintain NFTA cash position.
- Acceptance of legislative initiatives in support of NFTA funding needs.
- Favorable grant management review and audit findings.

MANAGEMENT INFORMATION SYSTEMS

DESCRIPTION

The mission of MIS is to provide the NFTA, its branch operations and business centers, with business systems analysis and automation to achieve efficient, timely and reliable system solutions at a reasonable cost.

PROGRAM AND SERVICE OBJECTIVES

- Continue to develop MIS policy and procedures to effectively manage the Authority's MIS resources.
- Plan, investigate, develop and install new applications and programming.
- Provide user support through training and maintenance programming.
- Make available over the NFTA network information needed by the user community.
- Successfully support user help calls directly or through other (vendors, education, etc.) resources.

